



Russell[®]
By Rheem

MODEL: RACAZR iR Packaged Air Conditioner

FORM NO. SRR-990 REV. 1

Russell[®] By Rheem Packaged Air Conditioner



RACAZR

- Cooling Efficiency: 13.4 SEER2



TABLE OF CONTENTS

Unit Features & Benefits	3-4
Model Number Identification	5
General Data	6-9
General Data Notes	10
Gross Systems Performance Data.....	11-20
Indoor Airflow Performance	21-28
Electrical Data	29-30
Electric Heater Kits	31-33
Dimensional Data.....	34-35
Typical Installations	36
Accessories	37-44
Limited Warranty	46

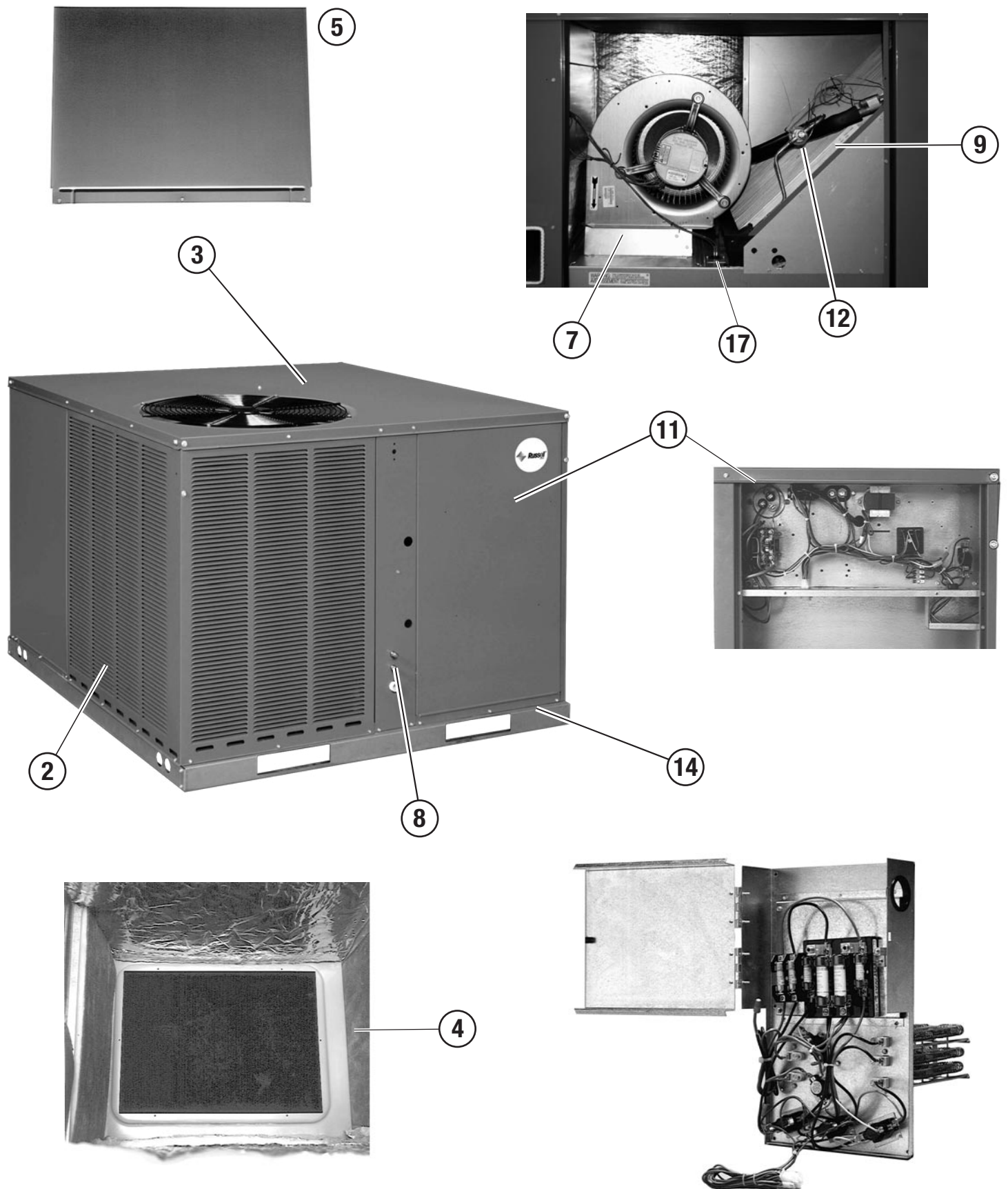



Features Below Correspond to Photos on Page 3

1. All models feature Scroll® compressors for maximum efficiency and quiet operation.
2. Louvered condenser compartment to protect the coil against yard hazards and/or weather extremes.
3. One-piece top with a drip flange to help keep water out of the unit.
4. Drawn supply and return air openings feature a one-inch tall flange to prevent water migration into the ductwork.
5. Access panels have “weep holes” and channels to further help manage water run-off.
6. All models are shipped ready for horizontal application.
7. Easily accessible blower section complete with slide-out blower.
8. Refrigerant connections are conveniently located for easy service diagnostics.
9. Micro Channel evaporator and condenser delivers superior performance with less refrigerant charge and less weight than conventional copper tube/aluminum fin coils. In addition the all aluminum construction has superior protection against formicary corrosion and aluminum tube rubbing potential. It is easier to clean and has a more robust surface.
10. Supplemental electric heat strips up to 15 kW are available (field installed) for periods of extreme cold temperatures. Single point wiring simplifies installation.
11. Easily accessible control box.
12. Thermal expansion valve standard on all models for superior superheat control, reliability, and energy efficiency at all operating conditions.
13. Solid core liquid line. Filter drier standard on all models (not shown).
14. Rugged baserail included for improved installation and handling.
15. Molded compressor plug.
16. Complete factory charged, wired and run tested.
17. A double sloped evaporator coil drain pan assures all water is removed from the unit to improve indoor air quality.

Packaged Air Conditioner

<u>R</u>	<u>AC</u>	<u>A</u>	<u>Z</u>	<u>R</u>	<u>024</u>	<u>A</u>	<u>J</u>	<u>T</u>	<u>000</u>	<u>N</u>	<u>A</u>
Brand	Product Category	Platform	Refrigerant	Tier	Capacity BTU/HR	Major Series	Voltage	Drive	Electric Heat	Control	Minor Series
R - Russell® By Rheem	AC - Straight Cool	A- ResiPack Convertible	Z - R-410A	R - Base Tier (13.4 SEER2)	024 - 24,000 [7.03 kW] 030 - 30,000 [8.79 kW] 036 - 36,000 [10.55 kW] 042 - 42,000 [12.31 kW] 048 - 48,000 [14.07 kW] 060 - 60,000 [17.58 kW]	A - 1st Design	J - 1ph, 208-230/60 C - 3ph, 208-230/60 D - 3ph, 460/60	T - Constant Torque	000 - No Electric Heat	N - Non-Communicating	A - 1st Design

[] Designates Metric Conversions

Available Models
RACAZR024AJT000NA
RACAZR030AJT000NA
RACAZR036ACT000NA
RACAZR036ADT000NA
RACAZR036AJT000NA
RACAZR042ACT000NA
RACAZR042AJT000NA
RACAZR048ACT000NA
RACAZR048ADT000NA
RACAZR048AJT000NA
RACAZR060ACT000NA
RACAZR060ADT000NA
RACAZR060AJT000NA

NOTE: **Bold** represents 2-stage cooling models.

NOMINAL SIZES 2-5 TONS [7.0-17.6 kW]

Model RACAZR Series	024AJT	030AJT	036ACT	036ADT
Cooling Performance¹				CONTINUED →
Gross Cooling Capacity Btu [kW]	23,600 [6.91]	29,400 [8.61]	35,200 [10.31]	35,200 [10.31]
EER2/SEER2 (1-phase) ²	10.6/13.4	10.6/13.4	10.6/13.4	10.6/13.4
EER/SEER (3-phase) ²	—	—	11/14	11/14
Nominal CFM/AHRI Rated CFM [L/s]	800/810 [378/382]	1000/980 [472/462]	1200/1180 [566/557]	1200/1180 [566/557]
AHRI Net Cooling Capacity Btu [kW]	23,000 [6.74]	28,400 [8.32]	34,200 [10.02]	34,200 [10.02]
Net Sensible Capacity Btu [kW]	16,700 [4.89]	21,100 [6.18]	25,100 [7.35]	25,100 [7.35]
Net Latent Capacity Btu [kW]	6,300 [1.85]	7,300 [2.14]	9,100 [2.67]	9,100 [2.67]
Net System Power kW	2.04	2.49	2.81	2.81
Compressor				
No./Type	1/Scroll	1/Scroll	1/Scroll	1/Scroll
Outdoor Sound Rating (dB)³	77	79	75	75
Outdoor Coil—Fin Type	Louvered	Louvered	Louvered	Louvered
Tube Type	MicroChannel	MicroChannel	MicroChannel	MicroChannel
MicroChannel Depth in. [mm]	0.472 [12]	0.709 [18]	0.709 [18]	0.709 [18]
Face Area sq. ft. [sq. m]	7.19 [0.67]	7.06 [0.66]	9.78 [0.91]	9.78 [0.91]
Rows / FPI [FPcm]	1 / 23 [9]	1 / 23 [9]	1 / 23 [9]	1 / 23 [9]
Indoor Coil—Fin Type	Louvered	Louvered	Louvered	Louvered
Tube Type	MicroChannel	MicroChannel	MicroChannel	MicroChannel
MicroChannel Depth in. [mm]	1 [25.4]	1 [25.4]	1 [25.4]	1 [25.4]
Face Area sq. ft. [sq. m]	3.54 [0.33]	3.54 [0.33]	3.54 [0.33]	3.54 [0.33]
Rows / FPI [FPcm]	1 / 20 [8]	1 / 20 [8]	1 / 20 [8]	1 / 20 [8]
Refrigerant Control	TX Valves	TX Valves	TX Valves	TX Valves
Drain Connection No./Size in. [mm]	1/0.75 [19.05]	1/0.75 [19.05]	1/0.75 [19.05]	1/0.75 [19.05]
Outdoor Fan—Type	Propeller	Propeller	Propeller	Propeller
No. Used/Diameter in. [mm]	1/22 [558.8]	1/22 [558.8]	1/22 [558.8]	1/22 [558.8]
Drive Type/No. Speeds	Direct/1	Direct/1	Direct/1	Direct/1
CFM [L/s]	2500 [1180]	2400 [1133]	3250 [1534]	3250 [1534]
No. Motors/HP	1 at 1/3 HP	1 at 1/3 HP	1 at 1/3 HP	1 at 1/3 HP
Motor RPM	825	825	825	825
Indoor Fan—Type	FC Centrifugal	FC Centrifugal	FC Centrifugal	FC Centrifugal
No. Used/Diameter in. [mm]	1/10x9 [254x229]	1/10x9 [254x229]	1/12x9 [305x229]	1/12x9 [305x229]
Drive Type	Direct	Direct	Direct	Direct
No. Speeds	Multiple	Multiple	Multiple	Multiple
No. Motors	1	1	1	1
Motor HP	1/3	1/2	1	1
Motor RPM	1050	1050	1050	1050
Motor Frame Size	48	48	48	48
Filter—Type	Field Supplied	Field Supplied	Field Supplied	Field Supplied
Furnished	No	No	No	No
(NO.) Size Recommended in. [mm x mm x mm]	(1)1x24x24 [25x610x610]	(1)1x24x24 [25x610x610]	(1)1x24x24 [25x610x610]	(1)1x24x24 [25x610x610]
Refrigerant Charge Oz. [g]	45.6 [1293]	48 [1361]	49.6 [1406]	49.6 [1406]
Weights				
Net Weight lbs. [kg]	354 [161]	354 [161]	363 [165]	363 [165]
Ship Weight lbs. [kg]	362 [164]	362 [164]	371 [168]	371 [168]

See Page 10 for Notes.

[] Designates Metric Conversions

NOMINAL SIZES 2-5 TONS [7.0-17.6 kW]

Model RACAZR Series	036AJT	042ACT	042AJT	048ACT
Cooling Performance¹				CONTINUED →
Gross Cooling Capacity Btu [kW]	35,600 [10.43]	42,000 [12.31]	42,500 [12.45]	48,000 [14.06]
EER2/SEER2 (1-phase) ²	10.6/13.4	10.6/13.4	10.6/13.4	10.6/13.4
EER/SEER (3-phase) ²	—	11/14	—	11/14
Nominal CFM/AHRI Rated CFM [L/s]	1200/1180 [566/557]	1400/1510 [661/713]	1400/1510 [661/713]	1600/1730 [755/816]
AHRI Net Cooling Capacity Btu [kW]	34,200 [10.02]	40,500 [11.87]	40,500 [11.87]	46,000 [13.48]
Net Sensible Capacity Btu [kW]	24,900 [7.3]	30,500 [8.94]	30,500 [8.94]	34,000 [9.96]
Net Latent Capacity Btu [kW]	9,300 [2.72]	10,000 [2.93]	10,000 [2.93]	12,000 [3.52]
Net System Power kW	2.98	3.45	3.6	4.11
Compressor				
No./Type	1/Scroll	1/Scroll	1/Scroll	1/Scroll
Outdoor Sound Rating (dB)³	75	77	77	76
Outdoor Coil—Fin Type	Louvered	Louvered	Louvered	Louvered
Tube Type	MicroChannel	MicroChannel	MicroChannel	MicroChannel
MicroChannel Depth in. [mm]	0.709 [18]	0.709 [18]	0.709 [18]	1 [25.4]
Face Area sq. ft. [sq. m]	9.78 [0.91]	16.18 [1.5]	16.18 [1.5]	15.37 [1.43]
Rows / FPI [FPcm]	1 / 23 [9]	1 / 23 [9]	1 / 23 [9]	1 / 23 [9]
Indoor Coil—Fin Type	Louvered	Louvered	Louvered	Louvered
Tube Type	MicroChannel	MicroChannel	MicroChannel	MicroChannel
MicroChannel Depth in. [mm]	1 [25.4]	1.26 [32]	1.26 [32]	1.26 [32]
Face Area sq. ft. [sq. m]	3.54 [0.33]	3.98 [0.37]	3.98 [0.37]	3.98 [0.37]
Rows / FPI [FPcm]	1 / 20 [8]	1 / 20 [8]	1 / 20 [8]	1 / 20 [8]
Refrigerant Control	TX Valves	TX Valves	TX Valves	TX Valves
Drain Connection No./Size in. [mm]	1/0.75 [19.05]	1/0.75 [19.05]	1/0.75 [19.05]	1/0.75 [19.05]
Outdoor Fan—Type	Propeller	Propeller	Propeller	Propeller
No. Used/Diameter in. [mm]	1/22 [558.8]	1/22 [558.8]	1/22 [558.8]	1/22 [558.8]
Drive Type/No. Speeds	Direct/1	Direct/1	Direct/1	Direct/1
CFM [L/s]	3250 [1534]	4300 [2029]	4300 [2029]	4150 [1958]
No. Motors/HP	1 at 1/3 HP	1 at 1/3 HP	1 at 1/3 HP	1 at 1/3 HP
Motor RPM	825	1050	1050	1050
Indoor Fan—Type	FC Centrifugal	FC Centrifugal	FC Centrifugal	FC Centrifugal
No. Used/Diameter in. [mm]	1/12x9 [305x229]	1/12x9 [305x229]	1/12x9 [305x229]	1/12x9 [305x229]
Drive Type	Direct	Direct	Direct	Direct
No. Speeds	Multiple	Multiple	Multiple	Multiple
No. Motors	1	1	1	1
Motor HP	1	3/4	3/4	1
Motor RPM	1050	1050	1050	1050
Motor Frame Size	48	48	48	48
Filter—Type	Field Supplied	Field Supplied	Field Supplied	Field Supplied
Furnished	No	No	No	No
(NO.) Size Recommended in. [mm x mm x mm]	(1)1x24x24 [25x610x610]	(1)1x24x24 [25x610x610]	(1)1x24x24 [25x610x610]	(1)1x24x24 [25x610x610]
Refrigerant Charge Oz. [g]	49.6 [1406]	72 [2041]	72 [2041]	88 [2495]
Weights				
Net Weight lbs. [kg]	363 [165]	428 [194]	428 [194]	447 [203]
Ship Weight lbs. [kg]	371 [168]	436 [198]	436 [198]	455 [206]

See Page 10 for Notes.

[] Designates Metric Conversions

NOMINAL SIZES 2-5 TONS [7.0-17.6 kW]

Model RACAZR Series	048ADT	048AJT	060ACT	060ADT
Cooling Performance¹				CONTINUED →
Gross Cooling Capacity Btu [kW]	48,000 [14.06]	48,500 [14.21]	58,000 [16.99]	58,000 [16.99]
EER2/SEER2 (1-phase) ²	10.6/13.4	10.6/13.4	10.6/13.4	10.6/13.4
EER/SEER (3-phase) ²	11/14	—	11/14	11/14
Nominal CFM/AHRI Rated CFM [L/s]	1600/1730 [755/816]	1600/1730 [755/816]	2000/1700 [944/802]	2000/1700 [944/802]
AHRI Net Cooling Capacity Btu [kW]	46,000 [13.48]	46,000 [13.48]	56,000 [16.41]	56,000 [16.41]
Net Sensible Capacity Btu [kW]	34,000 [9.96]	34,000 [9.96]	40,000 [11.72]	40,000 [11.72]
Net Latent Capacity Btu [kW]	12,000 [3.52]	12,000 [3.52]	16,000 [4.69]	16,000 [4.69]
Net System Power kW	4.11	4.33	5.02	5.02
Compressor				
No./Type	1/Scroll	1/Scroll	1/Scroll	1/Scroll
Outdoor Sound Rating (dB)³	76	76	77	77
Outdoor Coil—Fin Type	Louvered	Louvered	Louvered	Louvered
Tube Type	MicroChannel	MicroChannel	MicroChannel	MicroChannel
MicroChannel Depth in. [mm]	1 [25.4]	1 [25.4]	1 [25.4]	1 [25.4]
Face Area sq. ft. [sq. m]	15.37 [1.43]	15.37 [1.43]	15.37 [1.43]	15.37 [1.43]
Rows / FPI [FPcm]	1 / 23 [9]	1 / 23 [9]	1 / 23 [9]	1 / 23 [9]
Indoor Coil—Fin Type	Louvered	Louvered	Louvered	Louvered
Tube Type	MicroChannel	MicroChannel	MicroChannel	MicroChannel
MicroChannel Depth in. [mm]	1.26 [32]	1.26 [32]	1.26 [32]	1.26 [32]
Face Area sq. ft. [sq. m]	3.98 [0.37]	3.98 [0.37]	3.96 [0.37]	3.96 [0.37]
Rows / FPI [FPcm]	1 / 20 [8]	1 / 20 [8]	1 / 20 [8]	1 / 20 [8]
Refrigerant Control	TX Valves	TX Valves	TX Valves	TX Valves
Drain Connection No./Size in. [mm]	1/0.75 [19.05]	1/0.75 [19.05]	1/0.75 [19.05]	1/0.75 [19.05]
Outdoor Fan—Type	Propeller	Propeller	Propeller	Propeller
No. Used/Diameter in. [mm]	1/22 [558.8]	1/22 [558.8]	1/22 [558.8]	1/22 [558.8]
Drive Type/No. Speeds	Direct/1	Direct/1	Direct/1	Direct/1
CFM [L/s]	4150 [1958]	4150 [1958]	4300 [2029]	4300 [2029]
No. Motors/HP	1 at 1/3 HP	1 at 1/3 HP	1 at 1/2 HP	1 at 1/2 HP
Motor RPM	1050	1050	1050	1050
Indoor Fan—Type	FC Centrifugal	FC Centrifugal	FC Centrifugal	FC Centrifugal
No. Used/Diameter in. [mm]	1/12x9 [305x229]	1/12x9 [305x229]	1/12x9 [305x229]	1/12x9 [305x229]
Drive Type	Direct	Direct	Direct	Direct
No. Speeds	Multiple	Multiple	Multiple	Multiple
No. Motors	1	1	1	1
Motor HP	1	1	1	1
Motor RPM	1050	1050	1050	1050
Motor Frame Size	48	48	48	48
Filter—Type	Field Supplied	Field Supplied	Field Supplied	Field Supplied
Furnished	No	No	No	No
(NO.) Size Recommended in. [mm x mm x mm]	(1)1x24x24 [25x610x610]	(1)1x24x24 [25x610x610]	(1)1x24x24 [25x610x610]	(1)1x24x24 [25x610x610]
Refrigerant Charge Oz. [g]	88 [2495]	88 [2495]	89.6 [2540]	89.6 [2540]
Weights				
Net Weight lbs. [kg]	447 [203]	447 [203]	450 [204]	450 [204]
Ship Weight lbs. [kg]	455 [206]	455 [206]	458 [208]	458 [208]

See Page 10 for Notes.

[] Designates Metric Conversions

NOMINAL SIZES 2-5 TONS [7.0-17.6 kW]

Model RACAZR Series	060AJT
Cooling Performance¹	
Gross Cooling Capacity Btu [kW]	58,500 [17.14]
EER2/SEER2 (1-phase) ²	10.6/13.4
EER/SEER (3-phase) ²	—
Nominal CFM/AHRI Rated CFM [L/s]	2000/1700 [944/802]
AHRI Net Cooling Capacity Btu [kW]	56,000 [16.41]
Net Sensible Capacity Btu [kW]	40,000 [11.72]
Net Latent Capacity Btu [kW]	16,000 [4.69]
Net System Power kW	5.16
Compressor	
No./Type	1/Scroll
Outdoor Sound Rating (dB)³	
	77
Outdoor Coil—Fin Type	
Tube Type	Louvered
MicroChannel Depth in. [mm]	MicroChannel
Face Area sq. ft. [sq. m]	1 [25.4]
Rows / FPI [FPcm]	15.37 [1.43]
	1 / 23 [9]
Indoor Coil—Fin Type	
Tube Type	Louvered
MicroChannel Depth in. [mm]	MicroChannel
Face Area sq. ft. [sq. m]	1.26 [32]
Rows / FPI [FPcm]	3.96 [0.37]
Refrigerant Control	1 / 20 [8]
Drain Connection No./Size in. [mm]	TX Valves
	1/0.75 [19.05]
Outdoor Fan—Type	
No. Used/Diameter in. [mm]	Propeller
Drive Type/No. Speeds	1/22 [558.8]
CFM [L/s]	Direct/1
No. Motors/HP	4300 [2029]
Motor RPM	1 at 1/2 HP
	1050
Indoor Fan—Type	
No. Used/Diameter in. [mm]	FC Centrifugal
Drive Type	1/12x9 [305x229]
No. Speeds	Direct
No. Motors	Multiple
Motor HP	1
Motor RPM	1
Motor Frame Size	1050
	48
Filter—Type	
Furnished	Field Supplied
(NO.) Size Recommended in. [mm x mm x mm]	No
	(1)1x24x24 [25x610x610]
Refrigerant Charge Oz. [g]	
	89.6 [2540]
Weights	
Net Weight lbs. [kg]	450 [204]
Ship Weight lbs. [kg]	458 [208]

See Page 10 for Notes.

[] Designates Metric Conversions

NOTES:

1. Cooling Performance is rated at 95°F ambient, 80°F entering dry bulb, 67°F entering wet bulb. Gross capacity does not include the effect of fan motor heat. AHRI capacity is net and includes the effect of fan motor heat. Units are suitable for operation to $\pm 20\%$ of nominal cfm. Units are certified in accordance with the Unitary Air Conditioner Equipment certification program, which is based on AHRI Standard 210/240 or 360.
2. EER2 and/or SEER2 are rated at AHRI conditions and in accordance with DOE test procedures for 1-Phase models. EER and/or SEER are rated at AHRI conditions and in accordance with DOE test procedures for 3-Phase models.
3. Outdoor Sound Rating shown is tested in accordance with AHRI Standard 270.

GROSS SYSTEMS PERFORMANCE DATA—RACAZR024AJT

ENTERING INDOOR AIR @ 80°F [26.7°C] dbE ①											
wbE		71°F [21.7°C]			67°F [19.4°C]			63°F [17.2°C]			
CFM [L/s]		900 [425]	810 [382]	700 [330]	900 [425]	810 [382]	700 [330]	900 [425]	810 [382]	700 [330]	
DR ①		0.17	0.19	0.22	0.17	0.19	0.22	0.17	0.19	0.22	
OUTDOOR DRY BULB TEMPERATURE °F [°C]	75 [23.9]	Total BTUH [kW] Sens BTUH [kW] Power	29.4 [8.6] 17.4 [5.1] 1.4	28.8 [8.4] 15.9 [4.7] 1.4	28.1 [8.2] 14.2 [4.2] 1.4	27.7 [8.1] 20.7 [6.1] 1.4	27.1 [7.9] 19.1 [5.6] 1.4	26.5 [7.8] 17.3 [5.1] 1.4	26.8 [7.9] 23.9 [7.0] 1.4	26.3 [7.7] 22.2 [6.5] 1.4	25.6 [7.5] 20.1 [5.9] 1.4
	80 [26.7]	Total BTUH [kW] Sens BTUH [kW] Power	28.5 [8.4] 16.9 [5.0] 1.5	27.9 [8.2] 15.5 [4.5] 1.5	27.3 [8.0] 14.0 [4.1] 1.5	26.8 [7.9] 20.2 [5.9] 1.5	26.3 [7.7] 18.7 [5.5] 1.5	25.6 [7.5] 16.9 [5.0] 1.5	25.9 [7.6] 23.4 [6.9] 1.5	25.4 [7.4] 21.7 [6.4] 1.5	24.8 [7.3] 19.8 [5.8] 1.5
	85 [29.4]	Total BTUH [kW] Sens BTUH [kW] Power	27.6 [8.1] 16.4 [4.8] 1.6	27.1 [7.9] 15.1 [4.4] 1.6	26.4 [7.7] 13.5 [4.0] 1.6	25.9 [7.6] 19.7 [5.8] 1.6	25.4 [7.4] 18.2 [5.3] 1.6	24.8 [7.3] 16.5 [4.8] 1.6	25.1 [7.4] 23.0 [6.7] 1.6	24.6 [7.2] 21.4 [6.3] 1.6	24.0 [7.0] 19.5 [5.7] 1.6
	90 [32.2]	Total BTUH [kW] Sens BTUH [kW] Power	26.8 [7.9] 16.0 [4.7] 1.7	26.2 [7.7] 14.6 [4.3] 1.7	25.6 [7.5] 13.1 [3.8] 1.7	25.1 [7.4] 19.4 [5.7] 1.7	24.6 [7.2] 17.9 [5.2] 1.7	24.0 [7.0] 16.2 [4.7] 1.7	24.2 [7.1] 22.5 [6.6] 1.7	23.7 [6.9] 20.9 [6.1] 1.7	23.1 [6.8] 19.0 [5.6] 1.7
	95 [35]	Total BTUH [kW] Sens BTUH [kW] Power	25.9 [7.6] 15.5 [4.5] 1.9	25.4 [7.4] 14.2 [4.2] 1.8	24.7 [7.2] 12.6 [3.7] 1.8	24.2 [7.1] 18.8 [5.5] 1.9	23.7 [6.9] 17.4 [5.1] 1.8	23.1 [6.8] 15.7 [4.6] 1.8	23.3 [6.8] 22.0 [6.4] 1.9	22.8 [6.7] 20.4 [6.0] 1.8	22.3 [6.5] 18.6 [5.4] 1.8
	100 [37.8]	Total BTUH [kW] Sens BTUH [kW] Power	25.0 [7.3] 15.0 [4.4] 2.0	24.5 [7.2] 13.8 [4.0] 2.0	23.9 [7.0] 12.4 [3.6] 1.9	23.3 [6.8] 18.3 [5.4] 2.0	22.8 [6.7] 16.9 [5.0] 2.0	22.2 [6.5] 15.3 [4.5] 1.9	22.4 [6.6] 21.6 [6.3] 2.0	21.9 [6.4] 20.0 [5.9] 2.0	21.4 [6.3] 18.3 [5.4] 1.9
	105 [40.6]	Total BTUH [kW] Sens BTUH [kW] Power	24.0 [7.0] 14.4 [4.2] 2.1	23.6 [6.9] 13.3 [3.9] 2.1	23.0 [6.7] 11.9 [3.5] 2.1	22.3 [6.5] 17.8 [5.2] 2.1	21.9 [6.4] 16.5 [4.8] 2.1	21.4 [6.3] 15.0 [4.4] 2.1	21.5 [6.3] 21.0 [6.2] 2.1	21.0 [6.2] 19.5 [5.7] 2.1	20.5 [6.0] 17.8 [5.2] 2.1
	110 [43.3]	Total BTUH [kW] Sens BTUH [kW] Power	23.1 [6.8] 14.0 [4.1] 2.3	22.6 [6.6] 12.8 [3.8] 2.2	22.1 [6.5] 11.5 [3.4] 2.2	21.4 [6.3] 17.3 [5.1] 2.3	21.0 [6.2] 16.0 [4.7] 2.2	20.5 [6.0] 14.5 [4.2] 2.2	20.5 [6.0] 20.4 [6.0] 2.3	20.1 [5.9] 19.0 [5.6] 2.2	19.6 [5.7] 17.3 [5.1] 2.2
	115 [46.1]	Total BTUH [kW] Sens BTUH [kW] Power	22.1 [6.5] 13.4 [3.9] 2.4	21.7 [6.4] 12.3 [3.6] 2.4	21.2 [6.2] 11.1 [3.3] 2.3	20.5 [6.0] 16.8 [4.9] 2.4	20.0 [5.9] 15.5 [4.5] 2.4	19.6 [5.7] 14.1 [4.1] 2.4	19.6 [5.7] 19.6 [5.7] 2.4	19.2 [5.6] 18.6 [5.4] 2.4	18.7 [5.5] 17.0 [5.0] 2.4

DR —Depression ratio
dbE —Entering air dry bulb
wbE—Entering air wet bulb

Total —Total capacity x 1000 BTUH
Sens —Sensible capacity x 1000 BTUH
Power —KW input

NOTES: ① When the entering air dry bulb is other than 80°F [27°C], adjust the sensible capacity from the table by adding [1.10 x CFM x (1 – DR) x (dbE – 80)].

[] Designates Metric Conversions

GROSS SYSTEMS PERFORMANCE DATA – RACAZR030AJT

ENTERING INDOOR AIR @ 80°F [26.7°C] dbE ①											
wbE		71°F [21.7°C]			67°F [19.4°C]			63°F [17.2°C]			
CFM [L/s]		1120 [529]	980 [463]	880 [415]	1120 [529]	980 [463]	880 [415]	1120 [529]	980 [463]	880 [415]	
DR ①		0.11	0.13	0.15	0.11	0.13	0.15	0.11	0.13	0.15	
INDOOR DRY BULB TEMPERATURE °F [°C]	75 [23.9]	Total BTUH [kW] Sens BTUH [kW] Power	36.4 [10.7] 23.0 [6.7] 1.8	35.5 [10.4] 20.7 [6.1] 1.7	34.8 [10.2] 19.0 [5.6] 1.7	34.3 [10.0] 26.6 [7.8] 1.8	33.5 [9.8] 24.1 [7.1] 1.7	32.8 [9.6] 22.3 [6.5] 1.7	32.9 [9.6] 30.3 [8.9] 1.8	32.0 [9.4] 27.5 [8.1] 1.7	31.4 [9.2] 25.6 [7.5] 1.7
	80 [26.7]	Total BTUH [kW] Sens BTUH [kW] Power	35.4 [10.4] 22.4 [6.6] 1.9	34.5 [10.1] 20.1 [5.9] 1.8	33.8 [9.9] 18.5 [5.4] 1.8	33.3 [9.8] 26.0 [7.6] 1.9	32.5 [9.5] 23.6 [6.9] 1.8	31.9 [9.3] 21.9 [6.4] 1.8	31.8 [9.3] 29.7 [8.7] 1.9	31.0 [9.1] 27.0 [7.9] 1.8	30.5 [8.9] 25.2 [7.4] 1.8
	85 [29.4]	Total BTUH [kW] Sens BTUH [kW] Power	34.3 [10.0] 21.8 [6.4] 2.0	33.4 [9.8] 19.5 [5.7] 2.0	32.8 [9.6] 18.0 [5.3] 1.9	32.3 [9.5] 25.5 [7.5] 2.0	31.5 [9.2] 23.1 [6.8] 2.0	30.9 [9.1] 21.4 [6.3] 1.9	30.8 [9.0] 29.1 [8.5] 2.0	30.0 [8.8] 26.5 [7.8] 2.0	29.5 [8.6] 24.8 [7.3] 1.9
	90 [32.2]	Total BTUH [kW] Sens BTUH [kW] Power	33.3 [9.8] 21.3 [6.2] 2.1	32.4 [9.5] 19.1 [5.6] 2.1	31.8 [9.3] 17.6 [5.2] 2.1	31.2 [9.1] 24.9 [7.3] 2.1	30.4 [8.9] 22.5 [6.6] 2.1	29.9 [8.8] 21.0 [6.2] 2.1	29.7 [8.7] 28.5 [8.4] 2.1	29.0 [8.5] 26.0 [7.6] 2.1	28.5 [8.4] 24.3 [7.1] 2.1
	95 [35]	Total BTUH [kW] Sens BTUH [kW] Power	32.2 [9.4] 20.7 [6.1] 2.2	31.4 [9.2] 18.6 [5.4] 2.2	30.8 [9.0] 17.1 [5.0] 2.2	30.1 [8.8] 24.3 [7.1] 2.2	29.4 [8.6] 22.1 [6.5] 2.2	28.8 [8.4] 20.5 [6.0] 2.2	28.7 [8.4] 28.1 [8.2] 2.2	27.9 [8.2] 25.5 [7.5] 2.2	27.4 [8.0] 23.8 [7.0] 2.2
	100 [37.8]	Total BTUH [kW] Sens BTUH [kW] Power	31.1 [9.1] 20.2 [5.9] 2.4	30.3 [8.9] 18.1 [5.3] 2.3	29.7 [8.7] 16.7 [4.9] 2.3	29.0 [8.5] 23.8 [7.0] 2.4	28.3 [8.3] 21.6 [6.3] 2.3	27.8 [8.1] 20.1 [5.9] 2.3	27.6 [8.1] 27.4 [8.0] 2.4	26.9 [7.9] 25.0 [7.3] 2.3	26.4 [7.7] 23.3 [6.8] 2.3
	105 [40.6]	Total BTUH [kW] Sens BTUH [kW] Power	29.9 [8.8] 19.5 [5.7] 2.5	29.2 [8.6] 17.6 [5.2] 2.5	28.6 [8.4] 16.2 [4.7] 2.5	27.9 [8.2] 23.3 [6.8] 2.5	27.2 [8.0] 21.1 [6.2] 2.5	26.7 [7.8] 19.6 [5.7] 2.5	26.4 [7.7] 26.4 [7.7] 2.5	25.8 [7.6] 24.6 [7.2] 2.5	25.3 [7.4] 23.0 [6.7] 2.5
	110 [43.3]	Total BTUH [kW] Sens BTUH [kW] Power	28.8 [8.4] 19.1 [5.6] 2.7	28.1 [8.2] 17.2 [5.0] 2.6	27.5 [8.1] 15.8 [4.6] 2.6	26.7 [7.8] 22.6 [6.6] 2.7	26.1 [7.6] 20.6 [6.0] 2.6	25.6 [7.5] 19.1 [5.6] 2.6	25.3 [7.4] 25.3 [7.4] 2.7	24.6 [7.2] 24.0 [7.0] 2.6	24.2 [7.1] 22.5 [6.6] 2.6
	115 [46.1]	Total BTUH [kW] Sens BTUH [kW] Power	27.6 [8.1] 18.5 [5.4] 2.8	26.9 [7.9] 16.6 [4.9] 2.8	26.4 [7.7] 15.3 [4.5] 2.8	25.6 [7.5] 22.2 [6.5] 2.8	24.9 [7.3] 20.1 [5.9] 2.8	24.5 [7.2] 18.8 [5.5] 2.8	24.1 [7.1] 24.1 [7.1] 2.8	23.5 [6.9] 23.5 [6.9] 2.8	23.1 [6.8] 22.0 [6.4] 2.8

DR —Depression ratio
dbE —Entering air dry bulb
wbE—Entering air wet bulb

Total —Total capacity x 1000 BTUH
Sens —Sensible capacity x 1000 BTUH
Power —KW input

NOTES: ① When the entering air dry bulb is other than 80°F [27°C], adjust the sensible capacity from the table by adding [1.10 x CFM x (1 – DR) x (dbE – 80)].

[] Designates Metric Conversions

GROSS SYSTEMS PERFORMANCE DATA—RACAZR036A(C/D)T

ENTERING INDOOR AIR @ 80°F [26.7°C] dbE ①											
wbE		71°F [21.7°C]			67°F [19.4°C]			63°F [17.2°C]			
CFM [L/s]		1350 [637]	1180 [557]	1050 [496]	1350 [637]	1180 [557]	1050 [496]	1350 [637]	1180 [557]	1050 [496]	
DR ①		0.14	0.16	0.19	0.14	0.16	0.19	0.14	0.16	0.19	
OUTDOOR DRY BULB TEMPERATURE °F [°C]	75 [23.9]	Total BTUH [kW] Sens BTUH [kW] Power	44.2 [13.0] 26.7 [7.8] 2.0	43.1 [12.6] 23.9 [7.0] 2.0	42.2 [12.4] 21.8 [6.4] 2.0	41.2 [12.1] 31.4 [9.2] 2.0	40.2 [11.8] 28.4 [8.3] 2.0	39.4 [11.5] 26.2 [7.7] 2.0	38.8 [11.4] 35.2 [10.3] 2.0	37.9 [11.1] 32.1 [9.4] 2.0	37.1 [10.9] 29.7 [8.7] 2.0
	80 [26.7]	Total BTUH [kW] Sens BTUH [kW] Power	43.0 [12.6] 26.1 [7.6] 2.1	41.9 [12.3] 23.4 [6.9] 2.1	41.1 [12.0] 21.4 [6.3] 2.1	40.0 [11.7] 30.7 [9.0] 2.1	39.0 [11.4] 27.8 [8.1] 2.1	38.2 [11.2] 25.6 [7.5] 2.1	37.6 [11.0] 34.6 [10.1] 2.1	36.7 [10.8] 31.5 [9.2] 2.1	35.9 [10.5] 29.1 [8.5] 2.1
	85 [29.4]	Total BTUH [kW] Sens BTUH [kW] Power	41.7 [12.2] 25.5 [7.5] 2.3	40.7 [11.9] 22.9 [6.7] 2.3	39.9 [11.7] 21.0 [6.2] 2.2	38.7 [11.3] 30.1 [8.8] 2.3	37.8 [11.1] 27.3 [8.0] 2.2	37.0 [10.8] 25.1 [7.4] 2.2	36.4 [10.7] 34.0 [10.0] 2.3	35.4 [10.4] 30.9 [9.1] 2.2	34.7 [10.2] 28.6 [8.4] 2.2
	90 [32.2]	Total BTUH [kW] Sens BTUH [kW] Power	40.4 [11.8] 24.8 [7.3] 2.4	39.4 [11.5] 22.2 [6.5] 2.4	38.6 [11.3] 20.3 [5.9] 2.4	37.4 [11.0] 29.5 [8.6] 2.4	36.5 [10.7] 26.7 [7.8] 2.4	35.7 [10.5] 24.6 [7.2] 2.4	35.1 [10.3] 33.4 [9.8] 2.4	34.2 [10.0] 30.4 [8.9] 2.4	33.5 [9.8] 28.2 [8.3] 2.4
	95 [35]	Total BTUH [kW] Sens BTUH [kW] Power	39.0 [11.4] 24.1 [7.1] 2.6	38.0 [11.1] 21.6 [6.3] 2.5	37.3 [10.9] 19.8 [5.8] 2.5	36.1 [10.6] 28.8 [8.4] 2.6	35.1 [10.3] 26.0 [7.6] 2.5	34.4 [10.1] 24.0 [7.0] 2.5	33.7 [9.9] 32.7 [9.6] 2.6	32.8 [9.6] 29.7 [8.7] 2.5	32.2 [9.4] 27.6 [8.1] 2.5
	100 [37.8]	Total BTUH [kW] Sens BTUH [kW] Power	37.6 [11.0] 23.4 [6.9] 2.7	36.7 [10.8] 21.0 [6.2] 2.7	35.9 [10.5] 19.2 [5.6] 2.7	34.6 [10.1] 28.0 [8.2] 2.7	33.7 [9.9] 25.3 [7.4] 2.7	33.1 [9.7] 23.4 [6.9] 2.7	32.3 [9.5] 32.0 [9.4] 2.7	31.4 [9.2] 29.1 [8.5] 2.7	30.8 [9.0] 27.0 [7.9] 2.7
	105 [40.6]	Total BTUH [kW] Sens BTUH [kW] Power	36.1 [10.6] 22.6 [6.6] 2.9	35.2 [10.3] 20.3 [5.9] 2.9	34.5 [10.1] 18.6 [5.4] 2.8	33.1 [9.7] 27.2 [8.0] 2.9	32.3 [9.5] 24.7 [7.2] 2.9	31.6 [9.3] 22.8 [6.7] 2.8	30.8 [9.0] 30.8 [9.0] 2.9	30.0 [8.8] 28.4 [8.3] 2.9	29.4 [8.6] 26.4 [7.7] 2.8
	110 [43.3]	Total BTUH [kW] Sens BTUH [kW] Power	34.6 [10.1] 21.9 [6.4] 3.1	33.7 [9.9] 19.6 [5.7] 3.0	33.0 [9.7] 17.9 [5.2] 3.0	31.6 [9.3] 26.5 [7.8] 3.1	30.8 [9.0] 24.0 [7.0] 3.0	30.2 [8.8] 22.2 [6.5] 3.0	29.2 [8.6] 29.2 [8.6] 3.1	28.5 [8.4] 27.7 [8.1] 3.0	27.9 [8.2] 25.7 [7.5] 3.0
	115 [46.1]	Total BTUH [kW] Sens BTUH [kW] Power	33.0 [9.7] 21.0 [6.2] 3.3	32.1 [9.4] 18.8 [5.5] 3.2	31.5 [9.2] 17.3 [5.1] 3.2	30.0 [8.8] 25.6 [7.5] 3.3	29.2 [8.6] 23.2 [6.8] 3.2	28.6 [8.4] 21.4 [6.3] 3.2	27.6 [8.1] 27.6 [8.1] 3.2	26.9 [7.9] 26.9 [7.9] 3.2	26.4 [7.7] 25.0 [7.3] 3.2

DR —Depression ratio
dbE —Entering air dry bulb
wbE—Entering air wet bulb

Total —Total capacity x 1000 BTUH
Sens —Sensible capacity x 1000 BTUH
Power —KW input

NOTES: ① When the entering air dry bulb is other than 80°F [27°C], adjust the sensible capacity from the table by adding [1.10 x CFM x (1 - DR) x (dbE - 80)].

[] Designates Metric Conversions

GROSS SYSTEMS PERFORMANCE DATA – RACAZR036AJT

		ENTERING INDOOR AIR @ 80°F [26.7°C] dbE ①									
wbE		71°F [21.7°C]			67°F [19.4°C]			63°F [17.2°C]			
CFM [L/s]		1350 [637]	1180 [557]	1050 [496]	1350 [637]	1180 [557]	1050 [496]	1350 [637]	1180 [557]	1050 [496]	
DR ①		0.13	0.16	0.18	0.13	0.16	0.18	0.13	0.16	0.18	
OUTDOOR DRY BULB TEMPERATURE °F [°C]	75 [23.9]	Total BTUH [kW] Sens BTUH [kW] Power	44.7 [13.1] 27.0 [7.9] 2.0	43.6 [12.8] 24.2 [7.1] 2.0	42.7 [12.5] 22.1 [6.5] 2.0	41.7 [12.2] 31.7 [9.3] 2.0	40.7 [11.9] 28.7 [8.4] 2.0	39.8 [11.7] 26.4 [7.7] 2.0	39.4 [11.5] 35.6 [10.4] 2.0	38.4 [11.3] 32.4 [9.5] 2.0	37.6 [11.0] 30.0 [8.8] 2.0
	80 [26.7]	Total BTUH [kW] Sens BTUH [kW] Power	43.5 [12.7] 26.5 [7.8] 2.2	42.4 [12.4] 23.7 [6.9] 2.1	41.5 [12.2] 21.6 [6.3] 2.1	40.5 [11.9] 31.1 [9.1] 2.2	39.5 [11.6] 28.1 [8.2] 2.1	38.7 [11.3] 25.9 [7.6] 2.1	38.2 [11.2] 35.0 [10.3] 2.2	37.2 [10.9] 31.8 [9.3] 2.1	36.4 [10.7] 29.4 [8.6] 2.1
	85 [29.4]	Total BTUH [kW] Sens BTUH [kW] Power	42.2 [12.4] 25.8 [7.6] 2.3	41.2 [12.1] 23.2 [6.8] 2.3	40.3 [11.8] 21.2 [6.2] 2.2	39.3 [11.5] 30.5 [8.9] 2.3	38.3 [11.2] 27.6 [8.1] 2.3	37.5 [11.0] 25.4 [7.4] 2.2	36.9 [10.8] 34.4 [10.1] 2.3	36.0 [10.5] 31.3 [9.2] 2.3	35.2 [10.3] 28.9 [8.5] 2.2
	90 [32.2]	Total BTUH [kW] Sens BTUH [kW] Power	40.9 [12.0] 25.1 [7.4] 2.4	39.9 [11.7] 22.5 [6.6] 2.4	39.1 [11.5] 20.6 [6.0] 2.4	37.9 [11.1] 29.8 [8.7] 2.4	37.0 [10.8] 2.07 [7.9] 2.4	36.2 [10.6] 24.9 [7.3] 2.4	35.6 [10.4] 33.7 [9.9] 2.4	34.7 [10.2] 30.7 [9.0] 2.4	34.0 [10.0] 28.5 [8.4] 2.4
	95 [35]	Total BTUH [kW] Sens BTUH [kW] Power	39.6 [11.6] 24.5 [7.2] 2.6	38.5 [11.3] 21.9 [6.4] 2.6	37.8 [11.1] 20.1 [5.9] 2.5	36.6 [10.7] 29.1 [8.5] 2.6	35.6 [10.4] 26.3 [7.7] 2.6	34.9 [10.2] 24.3 [7.1] 2.5	34.2 [10.0] 33.0 [9.7] 2.6	33.3 [9.8] 30.0 [8.8] 2.6	32.7 [9.6] 27.9 [8.2] 2.5
	100 [37.8]	Total BTUH [kW] Sens BTUH [kW] Power	38.1 [11.2] 23.7 [6.9] 2.8	37.2 [10.9] 21.3 [6.2] 2.7	36.4 [10.7] 19.4 [5.7] 2.7	35.1 [10.3] 28.3 [8.3] 2.7	34.2 [10.0] 25.6 [7.5] 2.7	33.6 [9.8] 23.7 [6.9] 2.7	32.8 [9.6] 32.3 [9.5] 2.7	31.9 [9.3] 29.4 [8.6] 2.7	31.3 [9.2] 27.3 [8.0] 2.7
	105 [40.6]	Total BTUH [kW] Sens BTUH [kW] Power	36.6 [10.7] 22.9 [6.7] 2.9	35.7 [10.5] 20.6 [6.0] 2.9	35.0 [10.3] 18.9 [5.5] 2.9	33.7 [9.9] 27.6 [8.1] 2.9	32.8 [9.6] 25.0 [7.3] 2.9	32.1 [9.4] 23.1 [6.8] 2.8	31.3 [9.2] 31.3 [9.2] 2.9	30.5 [8.9] 28.7 [8.4] 2.9	29.9 [8.8] 26.7 [7.8] 2.8
	110 [43.3]	Total BTUH [kW] Sens BTUH [kW] Power	35.1 [10.3] 22.2 [6.5] 3.1	34.2 [10.0] 19.9 [5.8] 3.1	33.5 [9.8] 18.2 [5.3] 3.0	32.1 [9.4] 26.8 [7.9] 3.1	31.3 [9.2] 24.3 [7.1] 3.0	30.7 [9.0] 22.5 [6.6] 3.0	29.7 [8.7] 29.7 [8.7] 3.1	29.0 [8.5] 28.0 [8.2] 3.0	28.4 [8.3] 26.0 [7.6] 3.0
	115 [46.1]	Total BTUH [kW] Sens BTUH [kW] Power	33.5 [9.8] 21.3 [6.2] 3.3	32.6 [9.6] 19.1 [5.6] 3.2	3.02 [9.4] 17.5 [5.1] 3.2	30.5 [8.9] 25.9 [7.6] 3.3	29.7 [8.7] 23.5 [6.9] 3.2	29.1 [8.5] 21.7 [6.4] 3.2	28.1 [8.2] 28.1 [8.2] 3.3	27.4 [8.0] 27.2 [8.0] 3.2	26.9 [7.9] 25.3 [7.4] 3.2

DR —Depression ratio
dbE —Entering air dry bulb
wbE—Entering air wet bulb

Total —Total capacity x 1000 BTUH
Sens —Sensible capacity x 1000 BTUH
Power —KW input

NOTES: ① When the entering air dry bulb is other than 80°F [27°C], adjust the sensible capacity from the table by adding [1.10 x CFM x (1 – DR) x (dbE – 80)].

[] Designates Metric Conversions

GROSS SYSTEMS PERFORMANCE DATA—RACAZR042ACT

ENTERING INDOOR AIR @ 80°F [26.7°C] dbE ①											
wbE		71°F [21.7°C]			67°F [19.4°C]			63°F [17.2°C]			
CFM [L/s]		1580 [746]	1510 [713]	1220 [576]	1580 [746]	1510 [713]	1220 [576]	1580 [746]	1510 [713]	1220 [576]	
DR ①		0.17	0.17	0.2	0.17	0.17	0.2	0.17	0.17	0.2	
OUTDOOR DRY BULB TEMPERATURE °F [°C]	75 [23.9]	Total BTUH [kW] Sens BTUH [kW] Power	51.4 [15.1] 30.9 [9.1] 2.3	51.0 [14.9] 29.8 [8.7] 2.3	49.2 [14.4] 25.5 [7.5] 2.3	48.3 [14.2] 36.1 [10.6] 2.3	47.9 [14.0] 34.9 [10.2] 2.3	46.2 [13.5] 30.2 [8.8] 2.3	45.8 [13.4] 40.0 [11.7] 2.4	45.4 [13.3] 38.8 [11.4] 2.3	43.8 [12.8] 33.9 [9.9] 2.3
	80 [26.7]	Total BTUH [kW] Sens BTUH [kW] Power	50.0 [14.6] 30.1 [8.8] 2.5	49.6 [14.5] 29.1 [8.5] 2.5	47.8 [14.0] 24.9 [7.3] 2.4	46.9 [13.7] 35.3 [10.3] 2.5	46.5 [13.6] 34.2 [10.0] 2.5	44.9 [13.2] 29.7 [8.7] 2.5	44.4 [13.0] 39.3 [11.5] 2.5	44.0 [12.9] 38.1 [11.2] 2.5	42.5 [12.5] 33.3 [9.8] 2.5
	85 [29.4]	Total BTUH [kW] Sens BTUH [kW] Power	48.5 [14.2] 29.3 [8.6] 2.7	48.1 [14.1] 28.3 [8.3] 2.6	46.4 [13.6] 24.2 [7.1] 2.6	45.4 [13.3] 34.5 [10.1] 2.7	45.0 [13.2] 33.4 [9.8] 2.7	43.5 [12.7] 29.0 [8.5] 2.6	42.9 [12.6] 38.5 [11.3] 2.7	42.6 [12.5] 37.4 [11.0] 2.7	41.1 [12.0] 32.7 [9.6] 2.6
	90 [32.2]	Total BTUH [kW] Sens BTUH [kW] Power	47.0 [13.8] 28.6 [8.4] 2.8	46.6 [13.7] 27.6 [8.1] 2.8	45.0 [13.2] 23.7 [6.9] 2.8	43.9 [12.9] 33.8 [9.9] 2.8	43.6 [12.8] 32.8 [9.6] 2.8	42.0 [12.3] 28.4 [8.3] 2.8	41.4 [12.1] 37.8 [11.1] 2.8	41.1 [12.0] 36.7 [10.8] 2.8	39.6 [11.6] 32.0 [9.4] 2.8
	95 [35]	Total BTUH [kW] Sens BTUH [kW] Power	45.5 [13.3] 27.9 [8.2] 3.0	45.1 [13.2] 26.9 [7.9] 3.0	43.6 [12.8] 23.1 [6.8] 2.9	42.4 [12.4] 33.1 [9.7] 3.0	42.0 [12.3] 32.0 [9.4] 3.0	40.6 [11.9] 27.9 [8.2] 3.0	39.9 [11.7] 37.1 [10.9] 3.0	39.6 [11.6] 36.0 [10.5] 3.0	38.2 [11.2] 31.5 [9.2] 3.0
	100 [37.8]	Total BTUH [kW] Sens BTUH [kW] Power	43.9 [12.9] 27.2 [8.0] 3.2	43.6 [12.8] 26.3 [7.7] 3.2	42.0 [12.3] 22.5 [6.6] 3.1	40.8 [12.0] 32.4 [9.5] 3.2	40.5 [11.9] 31.4 [9.2] 3.2	39.1 [11.5] 27.3 [8.0] 3.1	38.3 [11.2] 36.4 [10.7] 3.2	38.0 [11.1] 35.3 [10.3] 3.2	36.7 [10.8] 31.0 [9.1] 3.1
	105 [40.6]	Total BTUH [kW] Sens BTUH [kW] Power	42.3 [12.4] 26.5 [7.8] 3.4	41.9 [12.3] 25.5 [7.5] 3.4	40.5 [11.9] 21.9 [6.4] 3.3	39.2 [11.5] 31.6 [9.3] 3.4	38.9 [11.4] 30.6 [9.0] 3.4	37.5 [11.0] 26.6 [7.8] 3.3	36.7 [10.8] 35.6 [10.4] 3.4	36.4 [10.7] 34.5 [10.1] 3.4	35.1 [10.3] 30.2 [8.8] 3.3
	110 [43.3]	Total BTUH [kW] Sens BTUH [kW] Power	40.6 [11.9] 25.6 [7.5] 3.6	40.3 [11.8] 24.8 [7.3] 3.5	38.9 [11.4] 21.3 [6.2] 3.5	37.5 [11.0] 30.9 [9.1] 3.6	37.2 [10.9] 29.9 [8.8] 3.6	35.9 [10.5] 26.0 [7.6] 3.5	35.0 [10.3] 34.8 [10.2] 3.6	34.7 [10.2] 33.8 [9.9] 3.6	33.5 [9.8] 29.7 [8.7] 3.5
	115 [46.1]	Total BTUH [kW] Sens BTUH [kW] Power	38.9 [11.4] 24.9 [7.3] 3.8	38.6 [11.3] 24.1 [7.1] 3.7	37.2 [10.9] 20.7 [6.1] 3.7	35.8 [10.5] 30.0 [8.8] 3.8	35.5 [10.4] 29.1 [8.5] 3.8	34.3 [10.0] 25.4 [7.4] 3.7	33.3 [9.8] 33.3 [9.8] 3.8	33.0 [9.7] 33.0 [9.7] 3.8	31.8 [9.3] 28.9 [8.5] 3.7

DR —Depression ratio
dbE —Entering air dry bulb
wbE—Entering air wet bulb

Total —Total capacity x 1000 BTUH
Sens —Sensible capacity x 1000 BTUH
Power —KW input

NOTES: ① When the entering air dry bulb is other than 80°F [27°C], adjust the sensible capacity from the table by adding [1.10 x CFM x (1 – DR) x (dbE – 80)].

[] Designates Metric Conversions

GROSS SYSTEMS PERFORMANCE DATA – RACAZR042AJT

ENTERING INDOOR AIR @ 80°F [26.7°C] dbE ①											
wbE		71°F [21.7°C]			67°F [19.4°C]			63°F [17.2°C]			
CFM [L/s]		1580 [746]	1510 [713]	1220 [576]	1580 [746]	1510 [713]	1220 [576]	1580 [746]	1510 [713]	1220 [576]	
DR ①		0.15	0.16	0.19	0.15	0.16	0.19	0.15	0.16	0.19	
OUTDOOR DRY BULB TEMPERATURE °F [°C]	75 [23.9]	Total BTUH [kW] Sens BTUH [kW] Power	51.8 [15.2] 31.3 [9.2] 2.4	51.4 [15.1] 30.2 [8.8] 2.4	49.6 [14.5] 25.9 [7.6] 2.3	48.7 [14.3] 36.5 [10.7] 2.4	48.3 [14.2] 35.3 [10.3] 2.4	46.6 [13.7] 30.6 [9.0] 2.3	46.2 [13.5] 40.5 [11.9] 2.4	45.8 [13.4] 39.2 [11.5] 2.4	44.2 [13.0] 34.2 [10.0] 2.3
	80 [26.7]	Total BTUH [kW] Sens BTUH [kW] Power	50.4 [14.8] 30.5 [8.9] 2.5	50.0 [14.6] 29.5 [8.6] 2.5	48.3 [14.2] 25.3 [7.4] 2.5	47.3 [13.9] 35.8 [10.5] 2.5	46.9 [13.7] 34.6 [10.1] 2.5	45.3 [13.3] 30.0 [8.8] 2.5	44.8 [13.1] 39.7 [11.6] 2.5	44.4 [13.0] 38.5 [11.3] 2.5	42.9 [12.6] 33.7 [9.9] 2.5
	85 [29.4]	Total BTUH [kW] Sens BTUH [kW] Power	49.0 [14.4] 29.8 [8.7] 2.7	48.6 [14.2] 28.8 [8.4] 2.7	46.9 [13.7] 24.7 [7.2] 2.6	45.9 [13.4] 35.0 [10.3] 2.7	45.5 [13.3] 33.9 [9.9] 2.7	43.9 [12.9] 29.4 [8.6] 2.6	43.4 [12.7] 39.0 [11.4] 2.7	43.0 [12.6] 37.8 [11.1] 2.7	41.5 [12.2] 33.0 [9.7] 2.6
	90 [32.2]	Total BTUH [kW] Sens BTUH [kW] Power	47.5 [13.9] 29.1 [8.5] 2.9	47.1 [13.8] 28.1 [8.2] 2.8	45.5 [13.3] 24.1 [7.1] 2.8	44.4 [13.0] 34.3 [10.0] 2.9	44.0 [12.9] 33.2 [9.7] 2.8	42.5 [12.5] 28.9 [8.5] 2.8	41.9 [12.3] 38.3 [11.2] 2.9	41.5 [12.2] 37.1 [10.9] 2.9	40.1 [11.7] 32.5 [9.5] 2.8
	95 [35]	Total BTUH [kW] Sens BTUH [kW] Power	46.0 [13.5] 28.4 [8.3] 3.0	45.6 [13.4] 27.4 [8.0] 3.0	44.0 [12.9] 23.5 [6.9] 3.0	42.8 [12.5] 33.5 [9.8] 3.0	42.5 [12.5] 32.5 [9.5] 3.0	41.0 [12.0] 28.2 [8.3] 3.0	40.3 [11.8] 37.5 [11.0] 3.0	40.0 [11.7] 36.4 [10.7] 3.0	38.6 [11.3] 31.9 [9.3] 3.0
	100 [37.8]	Total BTUH [kW] Sens BTUH [kW] Power	44.4 [13.0] 27.7 [8.1] 3.2	44.0 [12.9] 26.7 [7.8] 3.2	42.5 [12.5] 22.9 [6.7] 3.1	41.3 [12.1] 32.9 [9.6] 3.2	40.9 [12.0] 31.8 [9.3] 3.2	39.5 [11.6] 27.7 [8.1] 3.1	38.8 [11.4] 36.9 [10.8] 3.2	38.4 [11.3] 35.7 [10.5] 3.2	37.1 [10.9] 31.3 [9.2] 3.2
	105 [40.6]	Total BTUH [kW] Sens BTUH [kW] Power	42.7 [12.5] 26.9 [7.9] 3.4	42.4 [12.4] 26.0 [7.6] 3.4	40.9 [12.0] 22.3 [6.5] 3.3	39.6 [11.6] 32.0 [9.4] 3.4	39.3 [11.5] 31.0 [9.1] 3.4	37.9 [11.1] 26.9 [7.9] 3.3	37.1 [10.9] 36.0 [10.5] 3.4	36.8 [10.8] 34.9 [10.2] 3.4	35.5 [10.4] 30.6 [9.0] 3.3
	110 [43.3]	Total BTUH [kW] Sens BTUH [kW] Power	41.1 [12.0] 26.2 [7.7] 3.6	40.7 [11.9] 25.2 [7.4] 3.6	39.3 [11.5] 21.7 [6.4] 3.5	38.0 [11.1] 31.4 [9.2] 3.6	37.6 [11.0] 30.3 [8.9] 3.6	36.3 [10.6] 26.4 [7.7] 3.5	35.4 [10.4] 35.2 [10.3] 3.6	35.2 [10.3] 34.3 [10.0] 3.6	33.9 [9.9] 30.0 [8.8] 3.5
	115 [46.1]	Total BTUH [kW] Sens BTUH [kW] Power	39.4 [11.5] 25.4 [7.4] 3.8	39.0 [11.4] 24.5 [7.2] 3.8	37.7 [11.0] 21.1 [6.2] 3.7	36.2 [10.6] 30.4 [8.9] 3.8	35.9 [10.5] 29.5 [8.6] 3.8	34.7 [10.2] 25.8 [7.6] 3.7	33.7 [9.9] 33.7 [9.9] 3.8	33.4 [9.8] 33.4 [9.8] 3.8	32.3 [9.5] 29.4 [8.6] 3.7

DR —Depression ratio
dbE —Entering air dry bulb
wbE—Entering air wet bulb

Total —Total capacity x 1000 BTUH
Sens —Sensible capacity x 1000 BTUH
Power —KW input

NOTES: ① When the entering air dry bulb is other than 80°F [27°C], adjust the sensible capacity from the table by adding [1.10 x CFM x (1 – DR) x (dbE – 80)].

[] Designates Metric Conversions

GROSS SYSTEMS PERFORMANCE DATA—RACAZR048A(C/D)T

		ENTERING INDOOR AIR @ 80°F [26.7°C] dbE ①									
wbE		71°F [21.7°C]			67°F [19.4°C]			63°F [17.2°C]			
CFM [L/s]		1800 [850]	1730 [817]	1400 [661]	1800 [850]	1730 [817]	1400 [661]	1800 [850]	1730 [817]	1400 [661]	
DR ①		0.19	0.2	0.24	0.19	0.2	0.24	0.19	0.2	0.24	
OUTDOOR DRY BULB TEMPERATURE °F [°C]	75 [23.9]	Total BTUH [kW] Sens BTUH [kW] Power	58.2 [17.1] 33.0 [9.7] 3.0	57.7 [16.9] 31.9 [9.3] 3.0	55.7 [16.3] 27.2 [8.0] 2.9	54.1 [15.9] 39.3 [11.5] 2.9	53.7 [15.7] 38.2 [11.2] 2.9	51.8 [15.2] 33.1 [9.7] 2.9	50.7 [14.9] 44.0 [12.9] 2.9	50.3 [14.7] 42.8 [12.5] 2.9	48.6 [14.2] 37.4 [11.0] 2.9
	80 [26.7]	Total BTUH [kW] Sens BTUH [kW] Power	56.9 [16.7] 32.5 [9.5] 3.1	56.5 [16.6] 31.5 [9.2] 3.1	54.5 [16.0] 26.9 [7.9] 3.1	52.8 [15.5] 38.9 [11.4] 3.1	52.4 [15.4] 37.8 [11.1] 3.1	50.6 [14.8] 32.8 [9.6] 3.0	49.4 [14.5] 43.5 [12.7] 3.0	49.1 [14.4] 42.4 [12.4] 3.0	47.4 [13.9] 37.1 [10.9] 3.0
	85 [29.4]	Total BTUH [kW] Sens BTUH [kW] Power	55.5 [16.3] 32.0 [9.4] 3.3	55.1 [16.1] 31.0 [9.1] 3.3	53.2 [15.6] 26.5 [7.8] 3.2	51.4 [15.1] 38.4 [11.3] 3.2	51.0 [14.9] 37.3 [10.9] 3.2	49.3 [14.4] 32.4 [9.5] 3.2	48.1 [14.1] 43.1 [12.6] 3.2	47.7 [14.0] 41.9 [12.3] 3.2	46.1 [13.5] 36.7 [10.8] 3.1
	90 [32.2]	Total BTUH [kW] Sens BTUH [kW] Power	54.0 [15.8] 31.4 [9.2] 3.4	53.6 [15.7] 30.4 [8.9] 3.4	51.8 [15.2] 26.1 [7.6] 3.3	49.9 [14.6] 37.7 [11.0] 3.4	49.5 [14.5] 36.6 [10.7] 3.4	47.8 [14.0] 31.8 [9.3] 3.3	46.6 [13.7] 42.5 [12.5] 3.3	46.2 [13.5] 41.3 [12.1] 3.3	44.6 [13.1] 36.2 [10.6] 3.3
	95 [35]	Total BTUH [kW] Sens BTUH [kW] Power	52.4 [15.4] 30.6 [9.0] 3.6	52.0 [15.2] 29.6 [8.7] 3.6	50.2 [14.7] 25.3 [7.4] 3.5	48.3 [14.2] 37.0 [10.8] 3.5	48.0 [14.1] 36.0 [10.5] 3.5	46.3 [13.6] 31.2 [9.1] 3.5	45.0 [13.2] 41.7 [12.2] 3.5	44.6 [13.1] 40.5 [11.9] 3.5	43.1 [12.6] 35.5 [10.4] 3.4
	100 [37.8]	Total BTUH [kW] Sens BTUH [kW] Power	50.7 [14.9] 29.8 [8.7] 3.8	50.3 [14.7] 28.8 [8.4] 3.7	48.6 [14.2] 24.7 [7.2] 3.7	46.6 [13.7] 36.1 [10.6] 3.7	46.3 [13.6] 35.1 [10.3] 3.7	44.7 [13.1] 30.5 [8.9] 3.7	43.3 [12.7] 40.9 [12.0] 3.7	43.0 [12.6] 39.8 [11.7] 3.7	41.5 [12.2] 34.9 [10.2] 3.6
	105 [40.6]	Total BTUH [kW] Sens BTUH [kW] Power	48.9 [14.3] 28.7 [8.4] 3.9	48.6 [14.2] 27.9 [8.2] 3.9	46.9 [13.7] 23.9 [7.0] 3.9	44.8 [13.1] 35.2 [10.3] 3.9	44.5 [13.0] 34.2 [10.0] 3.9	42.9 [12.6] 29.7 [8.7] 3.8	41.5 [12.2] 39.8 [11.7] 3.9	41.2 [12.1] 38.8 [11.4] 3.9	39.7 [11.6] 34 [10.0] 3.8
	110 [43.3]	Total BTUH [kW] Sens BTUH [kW] Power	47.0 [13.8] 27.7 [8.1] 4.1	46.7 [13.7] 26.9 [7.9] 4.1	45.0 [13.2] 23.0 [6.7] 4.1	42.9 [12.6] 34.0 [10.0] 4.1	42.6 [12.5] 33.1 [9.7] 4.1	41.1 [12.0] 28.8 [8.4] 4.0	39.6 [11.6] 38.8 [11.4] 4.1	39.3 [11.5] 37.8 [11.1] 4.1	37.9 [11.1] 33.2 [9.7] 4
	115 [46.1]	Total BTUH [kW] Sens BTUH [kW] Power	45.0 [13.2] 26.5 [7.8] 4.4	44.7 [13.1] 25.7 [7.5] 4.3	43.1 [12.6] 22.0 [6.4] 4.3	40.9 [12.0] 32.8 [9.6] 4.3	40.6 [11.9] 31.9 [9.3] 4.3	39.2 [11.5] 27.8 [8.1] 4.2	37.5 [11.0] 37.5 [11.0] 4.3	37.3 [10.9] 36.6 [10.7] 4.3	36.0 [10.5] 32.2 [9.4] 4.2

DR —Depression ratio
dbE —Entering air dry bulb
wbE—Entering air wet bulb

Total —Total capacity x 1000 BTUH
Sens —Sensible capacity x 1000 BTUH
Power —KW input

NOTES: ① When the entering air dry bulb is other than 80°F [27°C], adjust the sensible capacity from the table by adding [1.10 x CFM x (1 – DR) x (dbE – 80)].

[] Designates Metric Conversions

GROSS SYSTEMS PERFORMANCE DATA – RACAZR048AJT

		ENTERING INDOOR AIR @ 80°F [26.7°C] dbE ①									
wbE		71°F [21.7°C]			67°F [19.4°C]			63°F [17.2°C]			
CFM [L/s]		1800 [850]	1730 [817]	1400 [661]	1800 [850]	1730 [817]	1400 [661]	1800 [850]	1730 [817]	1400 [661]	
DR ①		0.18	0.19	0.22	0.18	0.19	0.22	0.18	0.19	0.22	
OUTDOOR DRY BULB TEMPERATURE °F [°C]	75 [23.9]	Total BTUH [kW] Sens BTUH [kW] Power	58.7 [17.2] 33.5 [9.8] 3.0	58.3 [17.1] 32.5 [9.5] 3.0	56.3 [16.5] 27.8 [8.1] 3.0	54.6 [16.0] 39.8 [11.7] 3	54.2 [15.9] 38.7 [11.3] 3.0	52.4 [15.4] 33.6 [9.8] 2.9	51.3 [15.0] 44.6 [13.1] 3.0	50.9 [14.9] 43.4 [12.7] 3.0	49.2 [14.4] 38.0 [11.1] 2.9
	80 [26.7]	Total BTUH [kW] Sens BTUH [kW] Power	57.5 [16.8] 33.1 [9.7] 3.2	57.0 [16.7] 32.0 [9.4] 3.2	55.1 [16.1] 27.4 [8.0] 3.1	53.4 [15.6] 39.5 [11.6] 3.1	53.0 [15.5] 38.4 [11.3] 3.1	51.1 [15.0] 33.3 [9.8] 3.1	50.0 [14.6] 44.1 [12.9] 3.1	49.6 [14.5] 42.9 [12.6] 3.1	47.9 [14.0] 37.5 [11.0] 3.0
	85 [29.4]	Total BTUH [kW] Sens BTUH [kW] Power	56.1 [16.4] 32.6 [9.6] 3.3	55.7 [16.3] 31.6 [9.3] 3.3	53.7 [15.7] 27.0 [7.9] 3.2	52.0 [15.2] 39.0 [11.4] 3.3	51.6 [15.1] 37.9 [11.1] 3.3	49.8 [14.6] 32.9 [9.6] 3.2	48.6 [14.2] 43.6 [12.8] 3.2	48.3 [14.2] 42.5 [12.5] 3.2	46.6 [13.7] 37.2 [10.9] 3.2
	90 [32.2]	Total BTUH [kW] Sens BTUH [kW] Power	54.6 [16.0] 32.0 [9.4] 3.5	54.2 [15.9] 31.0 [9.1] 3.5	52.3 [15.3] 26.5 [7.8] 3.4	50.5 [14.8] 38.3 [11.2] 3.4	50.1 [14.7] 37.2 [10.9] 3.4	48.4 [14.2] 32.3 [9.5] 3.4	47.1 [13.8] 43.0 [12.6] 3.4	46.8 [13.7] 41.9 [12.3] 3.4	45.2 [13.2] 36.7 [10.8] 3.3
	95 [35]	Total BTUH [kW] Sens BTUH [kW] Power	53.0 [15.5] 31.2 [9.1] 3.6	52.6 [15.4] 30.2 [8.8] 3.6	50.8 [14.9] 25.9 [7.6] 3.6	48.9 [14.3] 37.6 [11.0] 3.6	48.5 [14.2] 36.5 [10.7] 3.6	46.8 [13.7] 31.7 [9.3] 3.5	45.5 [13.3] 42.2 [12.4] 3.6	45.2 [13.2] 41.1 [12.0] 3.6	43.6 [12.8] 36.0 [10.5] 3.5
	100 [37.8]	Total BTUH [kW] Sens BTUH [kW] Power	51.3 [15.0] 30.4 [8.9] 3.8	50.9 [14.9] 29.4 [8.6] 3.8	49.2 [14.4] 25.2 [7.4] 3.7	47.2 [13.8] 36.7 [10.8] 3.8	46.8 [13.7] 35.6 [10.4] 3.8	45.2 [13.2] 31.0 [9.1] 3.7	43.8 [12.8] 41.4 [12.1] 3.7	43.5 [12.7] 40.3 [11.8] 3.7	42.0 [12.3] 35.3 [10.3] 3.7
	105 [40.6]	Total BTUH [kW] Sens BTUH [kW] Power	49.5 [14.5] 29.3 [8.6] 4.0	49.1 [14.4] 28.4 [8.3] 4.0	47.4 [13.9] 24.3 [7.1] 3.9	45.4 [13.3] 35.8 [10.5] 4.0	45.0 [13.2] 34.7 [10.2] 3.9	43.5 [12.7] 30.2 [8.8] 3.9	42.0 [12.3] 40.3 [11.8] 3.9	41.7 [12.2] 39.3 [11.5] 3.9	40.3 [11.8] 34.5 [10.1] 3.8
	110 [43.3]	Total BTUH [kW] Sens BTUH [kW] Power	47.6 [13.9] 28.3 [8.3] 4.2	47.2 [13.8] 27.4 [8.0] 4.2	45.6 [13.4] 23.5 [6.9] 4.1	43.5 [12.7] 34.6 [10.1] 4.2	43.2 [12.7] 33.7 [9.9] 4.1	41.7 [12.2] 29.3 [8.6] 4.1	40.1 [11.7] 39.3 [11.5] 4.1	39.8 [11.7] 38.3 [11.2] 4.1	38.5 [11.3] 33.7 [9.9] 4.0
	115 [46.1]	Total BTUH [kW] Sens BTUH [kW] Power	45.6 [13.4] 27.1 [7.9] 4.4	45.2 [13.2] 26.2 [7.7] 4.4	43.7 [12.8] 22.5 [6.6] 4.3	41.5 [12.2] 33.4 [9.8] 4.4	41.1 [12.0] 32.4 [9.5] 4.4	39.7 [11.6] 28.2 [8.3] 4.3	38.1 [11.2] 38.1 [11.2] 4.3	37.8 [11.1] 37.1 [10.9] 4.3	36.5 [10.7] 32.6 [9.6] 4.2

DR —Depression ratio
dbE —Entering air dry bulb
wbE—Entering air wet bulb

Total —Total capacity x 1000 BTUH
Sens —Sensible capacity x 1000 BTUH
Power —KW input

NOTES: ① When the entering air dry bulb is other than 80°F [27°C], adjust the sensible capacity from the table by adding [1.10 x CFM x (1 – DR) x (dbE – 80)].

[] Designates Metric Conversions

GROSS SYSTEMS PERFORMANCE DATA—RACAZR060A(C/D)T

ENTERING INDOOR AIR @ 80°F [26.7°C] dbE ①											
wbE		71°F [21.7°C]			67°F [19.4°C]			63°F [17.2°C]			
CFM [L/s]		2100 [991]	1700 [802]	1600 [755]	2100 [991]	1700 [802]	1600 [755]	2100 [991]	1700 [802]	1600 [755]	
DR ①		0.03	0.09	0.1	0.03	0.09	0.1	0.03	0.09	0.1	
OUTDOOR DRY BULB TEMPERATURE °F [°C]	75 [23.9]	Total BTUH [kW] Sens BTUH [kW] Power	73.8 [21.6] 47.1 [13.8] 3.8	70.7 [20.7] 39.3 [11.5] 3.7	70.0 [20.5] 37.5 [11.0] 3.7	68.8 [20.2] 54.5 [16.0] 3.7	66.0 [19.3] 46.3 [13.6] 3.6	65.2 [19.1] 44.3 [13.0] 3.6	64.4 [18.9] 60.9 [17.8] 3.6	61.7 [18.1] 52.2 [15.3] 3.6	61.1 [17.9] 50.2 [14.7] 3.6
	80 [26.7]	Total BTUH [kW] Sens BTUH [kW] Power	71.9 [21.1] 46.1 [13.5] 3.9	68.9 [20.2] 38.5 [11.3] 3.8	68.2 [20.0] 36.8 [10.8] 3.8	66.9 [19.6] 53.4 [15.6] 3.9	64.1 [18.8] 45.3 [13.3] 3.8	63.4 [18.6] 43.4 [12.7] 3.8	62.5 [18.3] 59.9 [17.6] 3.8	59.9 [17.6] 51.4 [15.1] 3.7	59.3 [17.4] 49.4 [14.5] 3.7
	85 [29.4]	Total BTUH [kW] Sens BTUH [kW] Power	69.9 [20.5] 44.8 [13.1] 4.1	67.0 [19.6] 37.5 [11.0] 4.0	66.3 [19.4] 35.8 [10.5] 4.0	64.9 [19.0] 52.3 [15.3] 4.1	62.2 [18.2] 44.4 [13.0] 4.0	61.5 [18.0] 42.5 [12.5] 4.0	60.5 [17.7] 58.7 [17.2] 4.0	58.0 [17.0] 50.4 [14.8] 3.9	57.4 [16.8] 48.4 [14.2] 3.9
	90 [32.2]	Total BTUH [kW] Sens BTUH [kW] Power	67.8 [19.9] 43.5 [12.7] 4.3	65.0 [19.0] 36.4 [10.7] 4.2	64.3 [18.8] 34.7 [10.2] 4.2	62.8 [18.4] 50.9 [14.9] 4.3	60.2 [17.6] 43.3 [12.7] 4.2	59.6 [17.5] 41.5 [12.2] 4.2	58.4 [17.1] 57.4 [16.8] 4.2	56.0 [16.4] 49.3 [14.4] 4.1	55.4 [16.2] 47.4 [13.9] 4.1
	95 [35]	Total BTUH [kW] Sens BTUH [kW] Power	65.6 [19.2] 42.1 [12.3] 4.5	62.9 [18.4] 35.2 [10.3] 4.4	62.3 [18.3] 33.7 [9.9] 4.4	60.6 [17.8] 49.5 [14.5] 4.5	58.1 [17.0] 42.1 [12.3] 4.4	57.5 [16.8] 40.4 [11.8] 4.4	56.2 [16.5] 55.9 [16.4] 4.4	53.9 [15.8] 48.1 [14.1] 4.3	53.3 [15.6] 46.2 [13.5] 4.3
	100 [37.8]	Total BTUH [kW] Sens BTUH [kW] Power	63.4 [18.6] 40.7 [11.9] 4.8	60.8 [17.8] 34.1 [10.0] 4.7	60.1 [17.6] 32.5 [9.5] 4.6	58.4 [17.1] 48.1 [14.1] 4.7	56.0 [16.4] 40.9 [12.0] 4.6	55.4 [16.2] 39.2 [11.5] 4.6	54.0 [15.8] 54.0 [15.8] 4.7	51.8 [15.2] 47.0 [13.8] 4.6	51.2 [15.0] 45.1 [13.2] 4.5
	105 [40.6]	Total BTUH [kW] Sens BTUH [kW] Power	61.0 [17.9] 39.1 [11.5] 5.0	58.5 [17.1] 32.7 [9.6] 4.9	57.9 [17.0] 31.2 [9.1] 4.9	56.1 [16.4] 46.5 [13.6] 5.0	53.8 [15.8] 39.6 [11.6] 4.9	53.2 [15.6] 37.9 [11.1] 4.8	51.7 [15.1] 51.7 [15.1] 4.9	49.5 [14.5] 45.6 [13.4] 4.8	49.0 [14.4] 43.9 [12.9] 4.8
	110 [43.3]	Total BTUH [kW] Sens BTUH [kW] Power	58.6 [17.2] 37.4 [11.0] 5.3	56.2 [16.5] 31.3 [9.2] 5.2	55.6 [16.3] 29.9 [8.8] 5.1	53.6 [15.7] 44.7 [13.1] 5.2	51.4 [15.1] 38.1 [11.2] 5.1	50.9 [14.9] 36.6 [10.7] 5.1	49.2 [14.4] 49.2 [14.4] 5.2	47.2 [13.8] 44.2 [13.0] 5.1	46.7 [13.7] 42.5 [12.5] 5.0
	115 [46.1]	Total BTUH [kW] Sens BTUH [kW] Power	56.1 [16.4] 35.6 [10.4] 5.5	53.8 [15.8] 29.8 [8.7] 5.4	53.3 [15.6] 28.5 [8.4] 5.4	51.1 [15.0] 42.9 [12.6] 5.5	49.0 [14.4] 36.6 [10.7] 5.4	48.5 [14.2] 35.1 [10.3] 5.3	46.7 [13.7] 46.7 [13.7] 5.4	44.8 [13.1] 42.7 [12.5] 5.3	44.3 [13.0] 41.0 [12.0] 5.3

DR —Depression ratio
dbE —Entering air dry bulb
wbE—Entering air wet bulb

Total —Total capacity x 1000 BTUH
Sens —Sensible capacity x 1000 BTUH
Power —KW input

NOTES: ① When the entering air dry bulb is other than 80°F [27°C], adjust the sensible capacity from the table by adding [1.10 x CFM x (1 – DR) x (dbE – 80)].

[] Designates Metric Conversions

GROSS SYSTEMS PERFORMANCE DATA – RACAZR060AJT

ENTERING INDOOR AIR @ 80°F [26.7°C] dbE ①											
wbE		71°F [21.7°C]			67°F [19.4°C]			63°F [17.2°C]			
CFM [L/s]		2100 [991]	1700 [802]	1600 [755]	2100 [991]	1700 [802]	1600 [755]	2100 [991]	1700 [802]	1600 [755]	
DR ①		0.02	0.08	0.09	0.02	0.08	0.09	0.02	0.08	0.09	
OUTDOOR DRY BULB TEMPERATURE °F [°C]	75 [23.9]	Total BTUH [kW] Sens BTUH [kW] Power	74.2 [21.7] 47.5 [13.9] 3.8	71.2 [20.9] 39.8 [11.7] 3.7	70.4 [20.6] 37.9 [11.1] 3.7	69.2 [20.3] 54.9 [16.1] 3.7	66.4 [19.5] 46.7 [13.7] 3.6	65.7 [19.2] 44.7 [13.1] 3.6	64.8 [19.0] 61.4 [18.0] 3.7	62.2 [18.2] 52.7 [15.4] 3.6	61.5 [18.0] 50.6 [14.8] 3.6
	80 [26.7]	Total BTUH [kW] Sens BTUH [kW] Power	72.3 [21.2] 46.5 [13.6] 3.9	69.4 [20.3] 39.0 [11.4] 3.9	68.6 [20.1] 37.2 [10.9] 3.8	67.3 [19.7] 53.8 [15.8] 3.9	64.6 [18.9] 45.8 [13.4] 3.8	63.9 [18.7] 43.9 [12.9] 3.8	62.9 [18.4] 60.4 [17.7] 3.8	60.3 [17.7] 51.8 [15.2] 3.8	59.7 [17.5] 49.8 [14.6] 3.7
	85 [29.4]	Total BTUH [kW] Sens BTUH [kW] Power	70.3 [20.6] 45.3 [13.3] 4.1	67.4 [19.7] 37.9 [11.1] 4.0	66.7 [19.5] 36.2 [10.6] 4.0	65.3 [19.1] 52.7 [15.4] 4.1	62.7 [18.4] 44.9 [13.2] 4.0	62 [18.2] 43 [12.6] 4.0	60.9 [17.8] 59.2 [17.3] 4.0	58.4 [17.1] 50.8 [14.9] 3.9	57.8 [16.9] 48.8 [14.3] 3.9
	90 [32.2]	Total BTUH [kW] Sens BTUH [kW] Power	68.2 [20.0] 43.9 [12.9] 4.3	65.4 [19.2] 36.8 [10.8] 4.2	64.7 [19.0] 35.1 [10.3] 4.2	63.3 [18.5] 51.5 [15.1] 4.3	60.7 [17.8] 43.8 [12.8] 4.2	60.0 [17.6] 41.9 [12.3] 4.2	58.9 [17.3] 57.9 [17.0] 4.2	56.4 [16.5] 49.7 [14.6] 4.1	55.8 [16.3] 47.8 [14.0] 4.1
	95 [35]	Total BTUH [kW] Sens BTUH [kW] Power	66.1 [19.4] 42.6 [12.5] 4.5	63.4 [18.6] 35.7 [10.5] 4.5	62.7 [18.4] 34.0 [10.0] 4.4	61.1 [17.9] 50.1 [14.7] 4.5	58.6 [17.2] 42.6 [12.5] 4.4	58.0 [17.0] 40.8 [12.0] 4.4	56.7 [16.6] 56.5 [16.6] 4.4	54.4 [15.9] 48.6 [14.2] 4.4	53.8 [15.8] 46.7 [13.7] 4.3
	100 [37.8]	Total BTUH [kW] Sens BTUH [kW] Power	63.8 [18.7] 41.2 [12.1] 4.8	61.2 [17.9] 34.5 [10.1] 4.7	60.6 [17.8] 33.0 [9.7] 4.7	58.9 [17.3] 48.6 [14.2] 4.7	56.4 [16.5] 41.3 [12.1] 4.6	55.8 [16.3] 39.6 [11.6] 4.6	54.5 [16.0] 54.5 [16.0] 4.7	52.2 [15.3] 47.4 [13.9] 4.6	51.7 [15.1] 45.6 [13.4] 4.6
	105 [40.6]	Total BTUH [kW] Sens BTUH [kW] Power	61.5 [18.0] 39.6 [11.6] 5.0	59.0 [17.3] 33.2 [9.7] 4.9	58.4 [17.1] 31.7 [9.3] 4.9	56.5 [16.6] 46.9 [13.7] 5.0	54.2 [15.9] 40.0 [11.7] 4.9	53.6 [15.7] 38.3 [11.2] 4.8	52.1 [15.3] 52.1 [15.3] 4.9	50.0 [14.6] 46.1 [13.5] 4.8	49.4 [14.5] 44.3 [13.0] 4.8
	110 [43.3]	Total BTUH [kW] Sens BTUH [kW] Power	59.1 [17.3] 38.0 [11.1] 5.3	56.7 [16.6] 31.8 [9.3] 5.2	56.1 [16.4] 30.3 [8.9] 5.1	54.1 [15.9] 45.3 [13.3] 5.2	51.9 [15.2] 38.6 [11.3] 5.1	51.3 [15.0] 37.0 [10.8] 5.1	49.7 [14.6] 49.7 [14.6] 5.2	47.7 [14.0] 44.7 [13.1] 5.1	47.2 [13.8] 43.0 [12.6] 5
	115 [46.1]	Total BTUH [kW] Sens BTUH [kW] Power	56.6 [16.6] 36.2 [10.6] 5.6	54.3 [15.9] 30.3 [8.9] 5.4	53.7 [15.7] 28.9 [8.5] 5.4	51.6 [15.1] 43.5 [12.7] 5.5	49.5 [14.5] 37.1 [10.9] 5.4	49.0 [14.4] 35.6 [10.4] 5.4	47.2 [13.8] 47.2 [13.8] 5.4	45.3 [13.3] 43.2 [12.7] 5.3	44.8 [13.1] 41.5 [12.2] 5.3

DR —Depression ratio
dbE —Entering air dry bulb
wbE—Entering air wet bulb

Total —Total capacity x 1000 BTUH
Sens —Sensible capacity x 1000 BTUH
Power —KW input

NOTES: ① When the entering air dry bulb is other than 80°F [27°C], adjust the sensible capacity from the table by adding [1.10 x CFM x (1 – DR) x (dbE – 80)].

[] Designates Metric Conversions

INDOOR AIRFLOW PERFORMANCE RACAZR - (208/230V, 1-PHASE) CONSTANT TORQUE MOTOR

Nominal Cooling Capacity Tons [kW]	Motor Speed from Factory		Recommended Speed Tap for Field Installed Heater Kit	Manufacturer Recommended Cooling Airflow (Min/Max)	Blower Size, Motor HP [W] & # of Speeds	Motor Tap - Usage	External Static Pressure - Inches W.C. [kPa] (Side Discharge-Dry Coil)											
	Cool	Heat					0.1 [0.02]	0.2 [0.05]	0.3 [0.07]	0.4 [0.10]	0.5 [0.12]	0.6 [0.15]	0.7 [0.17]	0.8 [0.20]	0.9 [0.22]	1.0 [0.25]		
							CFM	RPM	Watts	CFM	RPM	Watts	CFM	RPM	Watts	CFM	RPM	Watts
2.0 [7.03]	Tap 3	Tap 2	5 kW - Tap 1 8 kW - Tap 1 10 kW - Tap 2	700 CFM / 900 CFM	10X9 Blower 1/3 HP [249] 3 Speed (Constant Torque)	Tap 1 - FAN	CFM	757	651	570	488	414	335	283	251	201	144	
							RPM	591	633	700	767	814	858	899	944	985	1032	
							Watts	69	67	73	79	83	87	91	95	99	102	
							CFM	855	801	746	683	619	519	473	406	354	329	
							RPM	639	691	748	806	855	921	953	994	1034	1061	
	Tap 2	Tap 2	5 kW - Tap 1 8 kW - Tap 1 10 kW - Tap 2	700 CFM / 900 CFM	10X9 Blower 1/3 HP [249] 3 Speed (Constant Torque)	Tap 2 - Elec. Heat	CFM	90	96	102	109	115	123	126	131	136	140	
							RPM	725	771	819	867	911	983	1025	1065	1096	1130	
							Watts	136	143	150	159	165	176	184	190	195	200	
							CFM	1020	979	933	883	837	731	714	655	606	542	
							RPM	725	771	819	867	911	983	1025	1065	1096	1130	
2.5 [8.79]	Tap 3	Tap 2	5 kW - Tap 1 8 kW - Tap 1 10 kW - Tap 2	875 CFM / 1125 CFM	10X9 Blower 1/2 HP [372] 3 Speed (Constant Torque)	Tap 1 - FAN	CFM	751	650	536	464	391	322	296	259	214	165	
							RPM	591	636	696	760	810	858	892	942	982	1019	
							Watts	68	69	73	80	85	89	91	96	100	102	
							CFM	860	800	742	676	558	493	431	371	330	296	
							RPM	630	693	748	809	851	907	949	987	1020	1059	
	Tap 2	Tap 2	5 kW - Tap 1 8 kW - Tap 1 10 kW - Tap 2	875 CFM / 1125 CFM	10X9 Blower 1/2 HP [372] 3 Speed (Constant Torque)	Tap 2 - Elec. Heat	CFM	88	93	101	108	114	120	125	129	133	137	
							RPM	711	760	805	848	893	936	981	1029	1079	1123	1144
							Watts	160	167	175	184	191	199	208	217	224	229	
							CFM	1222	1177	1145	1098	1064	1017	980	936	833	701	
							RPM	830	874	909	947	981	1028	1070	1112	1153	1165	
Tap 1	Tap 2	5 kW - Tap 1 8 kW - Tap 1 10 kW - Tap 2	875 CFM / 1125 CFM	10X9 Blower 1/2 HP [372] 3 Speed (Constant Torque)	Tap 4 - Med Static Cool*	CFM	209	219	226	234	242	251	261	270	265	253		
						RPM	1631	1583	1537	1480	1406	1322	1216	1056	905	827		
						Watts	1049	1080	1095	1111	1123	1136	1146	1158	1168	1170		
						CFM	465	474	466	456	435	412	377	329	286	266		
						RPM	329	339	329	329	329	329	329	329	329	329		

NOTES:

- (1) For constant torque motors: Use motor taps 3-5 to achieve rated airflow at AHRI minimum External Static Pressure.
- (a) Use * marked tap for AHRI 210/240-2023
- (b) Use ** marked tap for AHRI 210/240-2017
- (2) Grayed out portions not recommended for use in field.

[] Designates Metric Conversions

INDOOR AIRFLOW PERFORMANCE RACAZR - (208/230V, 1-PHASE) CONSTANT TORQUE MOTOR (Con't.)

Nominal Cooling Capacity Tons [kW]	Motor Speed from Factory		Recommended Speed Tap for Field Installed Heater Kit	Manufacturer Recommended Cooling Airflow (Min/Max)	Blower Size, Motor HP [W] & # of Speeds	Motor Tap - Usage	External Static Pressure - Inches W.C. [kPa] (Side Discharge-Dry Coil)											
	Cool	Heat					0.1 [1.02]	0.2 [0.05]	0.3 [0.07]	0.4 [1.10]	0.5 [1.12]	0.6 [1.15]	0.7 [1.17]	0.8 [1.20]	0.9 [1.22]	1.0 [1.25]		
3.0 [10.55]	Tap 3	Heat	Tap 2	5 kW - Tap 1 8 kW - Tap 1 10 kW - Tap 2 15 kW - Tap 2	1050 CFM / 1350 CFM	12x9T Blower 1 HP [746] 3 Speed (Constant Torque)	Tap 1 - FAN	CFM	969	802	692	558	460	396	326	293	252	188
								RPM	589	603	678	717	766	791	818	855	886	911
								Watts	106	93	101	106	112	117	120	125	130	133
								CFM	1105	1050	1005	894	827	762	695	618	554	488
								RPM	644	690	729	804	848	879	908	944	968	990
		Watts	143	151	159	169	180	188	193	200	204	209						
		CFM	1321	1277	1237	1189	1152	1039	984	931	871	808						
		RPM	738	774	808	846	876	957	990	1022	1047	1073						
		Watts	222	231	240	249	257	280	287	295	302	309						
		CFM	1476	1439	1406	1378	1331	1295	1186	1134	1086	1037						
	RPM	809	843	872	901	937	964	1045	1076	1107	1139							
	Watts	298	308	318	330	339	349	374	385	398	406							
	CFM	1574	1538	1503	1469	1434	1401	1366	1268	1205	1125							
	RPM	859	890	921	951	982	1009	1035	1110	1138	1149							
	Watts	362	372	384	396	407	417	427	456	460	446							

NOTES:

- (1) For constant torque motors: Use motor taps 3-5 to achieve rated airflow at AHRI minimum External Static Pressure.
- (a) Use * marked tap for AHRI 210/240-2023
- (b) Use ** marked tap for AHRI 210/240-2017

(2) Grayed out portions not recommended for use in field.

DOWN DISCHARGE PRESSURE DROP (ADD TO EXTERNAL STATIC PRESSURE)						
CFM [L/s]	800 [378]	1000 [472]	1200 [566]	1400 [661]	1600 [755]	2000 [944]
Pressure Drop—Includes W.C. [kPa]	.02 [0.005]	.05 [0.012]	.07 [0.017]	.1 [0.025]	.12 [0.030]	.17 [0.042]

[] Designates Metric Conversions

INDOOR AIRFLOW PERFORMANCE RACAZR - (208/230V, 1-PHASE) CONSTANT TORQUE MOTOR (Con't.)

Nominal Cooling Capacity Tons [kW]	Motor Speed from Factory		Recommended Speed Tap for Field Installed Heater Kit	Manufacturer Recommended Cooling Airflow (Min/Max)	Blower Size, Motor HP [W] & # of Speeds	Motor Tap - Usage	External Static Pressure - Inches W.C. [kPa] (Side Discharge-Dry Coil)										
	Cool	Heat					0.1 [0.02]	0.2 [0.05]	0.3 [0.07]	0.4 [0.10]	0.5 [0.12]	0.6 [0.15]	0.7 [0.17]	0.8 [0.20]	0.9 [0.22]	1.0 [0.25]	
3.5 [12.31]	Tap 3	Tap 2	5 kW - Tap 1 8 kW - Tap 1 10 kW - Tap 2 15 kW - Tap 2	1225 CFM / 1575 CFM	12x9T Blower 3/4 HP [559] 3 Speed (Constant Torque)	Tap 1 - FAN	CFM	1103	1050	959	872	803	725	654	558	482	415
							RPM	612	651	715	763	795	837	870	908	937	952
							Watts	132	140	152	160	166	174	180	188	193	196
							CFM	1448	1402	1358	1313	1227	1164	1122	1058	1004	936
							RPM	750	780	812	844	906	946	967	1000	1032	1064
3.5 [12.31]	Tap 3	Tap 2	5 kW - Tap 1 8 kW - Tap 1 10 kW - Tap 2 15 kW - Tap 2	1225 CFM / 1575 CFM	12x9T Blower 3/4 HP [559] 3 Speed (Constant Torque)	Tap 2 - Elec. Heat	Watts	256	265	274	283	302	313	320	329	340	351
							CFM	1576	1532	1493	1452	1414	1311	1258	1223	1160	1114
							RPM	804	832	861	888	918	984	1019	1039	1070	1095
							Watts	321	330	340	348	359	382	393	401	412	421
							CFM	1734	1693	1644	1619	1582	1540	1463	1390	1312	1200
3.5 [12.31]	Tap 3	Tap 2	5 kW - Tap 1 8 kW - Tap 1 10 kW - Tap 2 15 kW - Tap 2	1225 CFM / 1575 CFM	12x9T Blower 3/4 HP [559] 3 Speed (Constant Torque)	Tap 4 - Med Static Cool*	RPM	867	896	917	939	967	992	1048	1092	1114	1130
							Watts	411	422	430	437	449	459	483	499	496	480
							CFM	1860	1824	1792	1760	1728	1691	1652	1495	1362	1258
							RPM	929	951	977	997	1023	1049	1071	1121	1134	1140
							Watts	509	519	533	541	554	566	577	560	530	504
4.0 [14.07]	Low Stage - Tap 3 High Stage - Tap 4	Tap 2	5 kW - Tap 1 8 kW - Tap 1 10 kW - Tap 2 15 kW - Tap 2	1400 CFM / 1800 CFM	12x9R Blower 1 HP [746] 5 Speed (Constant Torque)	Tap 1 - FAN	CFM	1211	1050	935	837	755	694	622	535	475	426
							RPM	588	591	636	690	728	756	788	829	861	889
							Watts	139	120	122	132	137	143	148	154	160	166
							CFM	1453	1400	1360	1304	1239	1155	1097	1036	987	921
							RPM	670	705	734	770	813	860	892	926	947	975
4.0 [14.07]	Low Stage - Tap 3 High Stage - Tap 4	Tap 2	5 kW - Tap 1 8 kW - Tap 1 10 kW - Tap 2 15 kW - Tap 2	1400 CFM / 1800 CFM	12x9R Blower 1 HP [746] 5 Speed (Constant Torque)	Tap 2 - Elec. Heat	Watts	215	226	233	243	255	268	277	286	292	300
							CFM	1404	1362	1311	1254	1168	1100	1026	976	914	860
							RPM	656	687	721	760	809	849	887	914	937	961
							Watts	200	209	218	227	241	251	260	268	274	280
							CFM	1800	1759	1723	1687	1625	1577	1516	1465	1418	1370
4.0 [14.07]	Low Stage - Tap 3 High Stage - Tap 4	Tap 2	5 kW - Tap 1 8 kW - Tap 1 10 kW - Tap 2 15 kW - Tap 2	1400 CFM / 1800 CFM	12x9R Blower 1 HP [746] 5 Speed (Constant Torque)	Tap 4 - High Stage Cool	RPM	866	889	916	937	974	1001	1035	1063	1088	1112
							Watts	400	408	419	429	445	456	470	481	492	506
							CFM	2048	2007	1977	1929	1896	1856	1823	1773	1725	1671
							RPM	966	993	1013	1041	1061	1085	1105	1133	1164	1181
							Watts	587	603	615	629	640	654	665	680	696	708

NOTES:

- (1) For constant torque motors: Use motor taps 3-5 to achieve rated airflow at AHRI minimum External Static Pressure.
- (a) Use * marked tap for AHRI 210/240-2023
- (b) Use ** marked tap for AHRI 210/240-2017
- (2) Grayed out portions not recommended for use in field.

[] Designates Metric Conversions

INDOOR AIRFLOW PERFORMANCE RACAZR - (208/230V, 1-PHASE) CONSTANT TORQUE MOTOR (Con't.)

Nominal Cooling Capacity Tons [kW]	Motor Speed from Factory		Recommended Speed Tap for Field Installed Heater Kit	Manufacturer Recommended Cooling Airflow (Min/Max)	Blower Size, Motor HP [W] & # of Speeds	Motor Tap - Usage	External Static Pressure - Inches W.C. [kPa]										
	Cool	Heat					0.1 [0.02]	0.2 [0.05]	0.3 [0.07]	0.4 [0.10]	0.5 [0.12]	0.6 [0.15]	0.7 [0.17]	0.8 [0.20]	0.9 [0.22]	1.0 [0.25]	
5.0 [17.59]	Low Stage - Tap 3	Tap 2	5 kW - Tap 1 8 kW - Tap 1 10 kW - Tap 2 15 kW - Tap 2	1750 CFM / 2250 CFM	12x9R Blower 1 HP [746] 5 Speed (Constant Torque)	Tap 1 - FAN	CFM	1132	1056	997	903	834	785	701	641	570	519
							RPM	661	696	725	778	802	825	862	888	926	947
							Watts	136	143	148	159	162	168	177	180	189	198
							CFM	1448	1403	1329	1274	1220	1158	1097	1029	973	932
							RPM	781	811	846	871	900	934	963	987	1007	1021
							Watts	251	258	266	273	282	293	303	309	319	326
	High Stage - Tap 4	Tap 2	5 kW - Tap 1 8 kW - Tap 1 10 kW - Tap 2 15 kW - Tap 2	1750 CFM / 2250 CFM	12x9R Blower 1 HP [746] 5 Speed (Constant Torque)	Tap 3 - Low Stage Cool	CFM	1476	1424	1349	1299	1242	1165	1106	1053	1001	962
							RPM	788	819	861	885	913	947	974	998	1018	1028
							Watts	258	264	280	287	295	305	313	321	331	337
							CFM	1985	1954	1916	1865	1831	1784	1744	1704	1663	1626
							RPM	997	1021	1044	1078	1099	1122	1143	1166	1186	1207
							Watts	599	612	624	640	652	666	677	689	700	711
High Stage - Tap 4	Tap 2	5 kW - Tap 1 8 kW - Tap 1 10 kW - Tap 2 15 kW - Tap 2	1750 CFM / 2250 CFM	12x9R Blower 1 HP [746] 5 Speed (Constant Torque)	Tap 4 - High Stage Cool *Med Static	CFM	2226	2192	2160	2128	2086	2051	2010	1954	1921	1883	
						RPM	1074	1101	1120	1138	1166	1187	1209	1240	1256	1274	
						Watts	815	833	845	857	875	891	904	926	936	949	
						CFM	1600	1566	1500	1449	1394	1335	1272	1206	1136	1062	
						RPM	845	833	815	797	779	762	746	730	714	698	
						Watts	1800	1755	1680	1600	1500	1400	1300	1200	1100	1000	

NOTES:

(1) For constant torque motors: Use motor taps 3-5 to achieve rated airflow at AHRI minimum External Static Pressure.

(a) Use * marked tap for AHRI 210/240-2023

(b) Use ** marked tap for AHRI 210/240-2017

(2) Grayed out portions not recommended for use in field.

DOWN DISCHARGE PRESSURE DROP (ADD TO EXTERNAL STATIC PRESSURE)							
CFM [L/s]	800 [378]	1000 [472]	1200 [566]	1400 [661]	1600 [755]	1800 [849]	2000 [944]
Pressure Drop—Includes W.C. [kPa]	.02 [.005]	.05 [.012]	.07 [.017]	.1 [.025]	.12 [.030]	.15 [.037]	.17 [.042]

[] Designates Metric Conversions

INDOOR AIRFLOW PERFORMANCE RACAZR - (208/230V, 3-PHASE) CONSTANT TORQUE MOTOR

Nominal Cooling Capacity Tons [kW]	Motor Speed from Factory		Recommended Speed Tap for Field Installed Heater Kit	Manufacturer Recommended Cooling Airflow (Min/Max)	Blower Size, Motor HP [W] & # of Speeds	Motor Tap - Usage	External Static Pressure - Inches W.C. [kPa] (Side Discharge-Dry Coil)											
	Cool	Heat					0.1 [1.02]	0.2 [1.05]	0.3 [1.07]	0.4 [1.10]	0.5 [1.12]	0.6 [1.15]	0.7 [1.17]	0.8 [1.20]	0.9 [1.22]	1.0 [1.25]		
3.0 [10.55]	Tap 3	Heat	Tap 2	5 kW - Tap 1 8 kW - Tap 1 10 kW - Tap 2 15 kW - Tap 2	1050 CFM / 1350 CFM	12x9T Blower 1 HP [746] 3 Speed (Constant Torque)	Tap 1 - FAN	CFM	969	802	692	558	460	396	326	293	252	188
								RPM	589	603	678	717	766	791	818	855	886	911
								Watts	106	93	101	106	112	117	120	125	130	133
								CFM	1105	1050	1005	894	827	762	695	618	554	488
								RPM	644	690	729	804	848	879	908	944	968	990
		Watts	143	151	159	169	180	188	193	200	204	209						
		CFM	1321	1277	1237	1189	1152	1039	984	931	871	808						
		RPM	738	774	808	846	876	957	990	1022	1047	1073						
		Watts	222	231	240	249	257	280	287	295	302	309						
		CFM	1476	1439	1406	1378	1331	1295	1186	1134	1086	1037						
	RPM	809	843	872	901	937	964	1045	1076	1107	1139							
	Watts	298	308	318	330	339	349	374	385	398	406							
	CFM	1574	1538	1503	1469	1434	1401	1366	1268	1205	1125							
	RPM	859	890	921	951	982	1009	1035	1110	1138	1149							
	Watts	362	372	384	396	407	417	427	456	460	446							
4.0 [14.07]	Low Stage - Tap 3	Heat	Tap 2	1400 CFM / 1800 CFM	12x9T Blower 1 HP [746] 5 Speed (Constant Torque)	Tap 1 - FAN	CFM	1107	1050	999	894	821	741	663	573	504	435	
							RPM	614	656	690	755	794	831	867	913	932	955	
							Watts	129	135	145	154	161	168	175	181	186	192	
							CFM	1442	1400	1360	1315	1263	1163	1125	1072	1013	934	
							RPM	758	787	814	847	876	944	969	996	1029	1061	
		Watts	248	258	264	274	282	302	310	315	327	338						
		CFM	1325	1275	1231	1179	1080	1018	967	893	812	748						
		RPM	702	735	766	800	867	902	930	962	995	1031						
		Watts	195	206	212	221	237	245	251	261	268	278						
		CFM	1812	1767	1739	1706	1668	1634	1588	1546	1510	1273						
	RPM	960	987	1006	1027	1047	1069	1095	1120	1137	1167							
	Watts	458	470	478	488	497	504	518	530	537	485							
	CFM	1858	1827	1797	1753	1722	1689	1639	1603	1542	1292							
	RPM	982	1009	1027	1050	1072	1092	1119	1135	1144	1167							
	Watts	500	512	520	531	542	551	563	565	555	486							

NOTES:

(1) For constant torque motors: Use motor taps 3-5 to achieve rated airflow at AHRI minimum External Static Pressure.

(a) Use * marked tap for AHRI 210/240-2023

(b) Use ** marked tap for AHRI 210/240-2017

(2) Grayed out portions not recommended for use in field.

[] Designates Metric Conversions

INDOOR AIRFLOW PERFORMANCE RACAZR - (208/230V, 3-PHASE) CONSTANT TORQUE MOTOR (Con't.)

Nominal Cooling Capacity Tons [kW]	Motor Speed from Factory		Recommended Speed Tap for Field Installed Heater Kit	Manufacturer Recommended Cooling Airflow (Min/Max)	Blower Size, Motor HP [W] & # of Speeds	Motor Tap - Usage	External Static Pressure - Inches W.C. [kPa]											
	Cool	Heat					0.1 [.02]	0.2 [.05]	0.3 [.07]	0.4 [.10]	0.5 [.12]	0.6 [.15]	0.7 [.17]	0.8 [.20]	0.9 [.22]	1.0 [.25]		
5.0 [17.59]		Low Stage - Tap 3	5 kW - Tap 1 8 kW - Tap 1 10 kW - Tap 2 15 kW - Tap 2	1750 CFM / 2250 CFM	12x9R Blower 1 HP [746] 5 Speed (Constant Torque)	Tap 1 - FAN	CFM	1132	1056	997	903	834	785	701	641	570	519	
							RPM	661	696	725	778	802	825	862	888	926	947	
							Watts	136	143	148	159	162	168	177	180	189	198	
		CFM					1448	1403	1329	1274	1220	1158	1097	1029	973	932		
		RPM					781	811	846	871	900	934	963	987	1007	1021		
		Watts					251	258	266	273	282	293	303	309	319	326		
	High Stage - Tap 4	High Stage - Tap 2	High Stage - Tap 4	5 kW - Tap 1 8 kW - Tap 1 10 kW - Tap 2 15 kW - Tap 2	1750 CFM / 2250 CFM	12x9R Blower 1 HP [746] 5 Speed (Constant Torque)	Tap 3 - Low Stage Cool	CFM	1381	1315	1253	1209	1151	1061	1002	937	865	816
								RPM	736	780	812	837	866	907	930	952	980	1005
								Watts	211	223	232	239	246	258	262	270	277	285
								CFM	1872	1844	1769	1732	1694	1654	1593	1548	1496	1439
								RPM	943	961	990	1010	1033	1060	1082	1110	1132	1164
								Watts	493	501	505	515	525	539	550	564	573	589
High Stage - Tap 5	High Stage - Tap 5	High Stage - Tap 5	5 kW - Tap 1 8 kW - Tap 1 10 kW - Tap 2 15 kW - Tap 2	1750 CFM / 2250 CFM	12x9R Blower 1 HP [746] 5 Speed (Constant Torque)	Tap 5 - High Stage Cool	CFM	2226	2192	2160	2128	2086	2051	2010	1954	1921	1883	
							RPM	1074	1101	1120	1138	1166	1187	1209	1240	1256	1274	
							Watts	815	833	845	857	875	891	904	926	936	949	

NOTES:

(1) For constant torque motors: Use motor taps 3-5 to achieve rated airflow at AHRI minimum External Static Pressure.

(a) Use * marked tap for AHRI 210/240-2023

(b) Use ** marked tap for AHRI 210/240-2017

(2) Grayed out portions not recommended for use in field.

DOWN DISCHARGE PRESSURE DROP (ADD TO EXTERNAL STATIC PRESSURE)						
CFM [L/s]	800 [378]	1000 [472]	1200 [566]	1400 [661]	1600 [755]	2000 [944]
Pressure Drop—Includes W.C. [kPa]	.02 [.005]	.05 [.012]	.07 [.017]	.1 [.025]	.12 [.030]	.17 [.042]

[] Designates Metric Conversions

INDOOR AIRFLOW PERFORMANCE RACAZR - (460V, 3-PHASE) CONSTANT TORQUE MOTOR

Nominal Cooling Capacity Tons [kW]	Motor Speed from Factory		Recommended Speed Tap for Field Installed Heater Kit	Manufacturer Recommended Cooling Airflow (Min/Max)	Blower Size, Motor HP [W] & # of Speeds	Motor Tap - Usage	External Static Pressure - inches W.C. [kPa] (Side Discharge-Dry Coil)										
	Cool	Heat					0.1 [1.02]	0.2 [1.05]	0.3 [1.07]	0.4 [1.10]	0.5 [1.12]	0.6 [1.15]	0.7 [1.17]	0.8 [1.20]	0.9 [1.22]	1.0 [1.25]	
3.0 [10.55]	Tap 3	Tap 2	5 kW - Tap 1 8 kW - Tap 1 10 kW - Tap 2 15 kW - Tap 2	1050 CFM / 1350 CFM	12x9T Blower 1 HP [746] 3 Speed (Constant Torque)	Tap 1 - FAN	CFM	953	800	711	580	490	419	354	317	298	238
							RPM	584	613	671	720	764	795	818	844	890	918
							Watts	107	109	111	116	122	127	131	134	142	146
							CFM	1092	1051	999	902	844	768	698	629	567	494
							RPM	646	684	727	803	842	883	913	949	968	998
							Watts	148	156	167	183	192	201	208	215	221	226
							CFM	1315	1274	1241	1197	1138	1065	1015	952	906	840
							RPM	737	774	807	845	893	950	983	1015	1046	1073
							Watts	234	244	254	265	280	297	307	318	326	335
													Tap 4 - Blank	CFM			
						Tap 5 - High Static Cool	CFM	1561	1531	1499	1462	1433	1394	1344	1290	1220	1126
						Tap 1 - FAN	CFM	852	879	908	943	971	1000	1039	1080	1130	1149
						Tap 2 - Elec. Heat	CFM	370	381	392	405	418	429	446	462	483	470
						Tap 3 - Low Stage Cool	CFM	1105	1050	1008	910	838	772	699	608	535	469
						Tap 4 - Med Static Cool	CFM	610	650	684	753	793	829	863	910	939	962
						Tap 5 - High Static Cool	CFM	134	143	149	167	172	179	187	197	204	208
						Tap 1 - FAN	CFM	1440	1400	1357	1322	1289	1199	1164	1109	1058	987
						Tap 2 - Elec. Heat	CFM	752	788	825	852	878	945	962	997	1028	1059
						Tap 3 - Low Stage Cool	CFM	262	272	284	294	304	326	332	344	354	365
						Tap 4 - Med Static Cool	CFM	1315	1272	1229	1188	1107	1051	997	931	862	797
						Tap 5 - High Static Cool	CFM	703	740	775	804	870	899	932	967	996	1025
						Tap 1 - FAN	CFM	208	219	229	236	256	264	274	284	292	300
						Tap 2 - Elec. Heat	CFM	1802	1764	1735	1701	1666	1630	1599	1564	1452	1354
						Tap 3 - Low Stage Cool	CFM	903	938	957	985	1012	1039	1060	1085	1142	1150
						Tap 4 - Med Static Cool	CFM	478	488	501	514	527	538	550	559	570	545
						Tap 5 - High Static Cool	CFM	1860	1828	1790	1769	1728	1706	1672	1624	1583	1514
						Tap 1 - FAN	CFM	933	957	982	1006	1036	1057	1083	1107	1122	1133
						Tap 2 - Elec. Heat	CFM	520	536	548	560	575	587	611	605	605	593

NOTES:

- (1) For constant torque motors: Use motor taps 3-5 to achieve rated airflow at AHRI minimum External Static Pressure.
- (a) Use * marked tap for AHRI 210/240-2023
- (b) Use ** marked tap for AHRI 210/240-2017
- (2) Grayed out portions not recommended for use in field.

[] Designates Metric Conversions

INDOOR AIRFLOW PERFORMANCE RACAZR - (460V, 3-PHASE) CONSTANT TORQUE MOTOR (Con't.)

Nominal Cooling Capacity Tons [kW]	Motor Speed from Factory		Recommended Speed Tap for Field Installed Heater Kit	Manufacturer Recommended Cooling Airflow (Min/Max)	Blower Size, Motor HP [W] & # of Speeds	Motor Tap - Usage	External Static Pressure - Inches W.C. [kPa]										
	Cool	Heat					0.1 [.02]	0.2 [.05]	0.3 [.07]	0.4 [.10]	0.5 [.12]	0.6 [.15]	0.7 [.17]	0.8 [.20]	0.9 [.22]	1.0 [.25]	
5.0 [17.59]	Low Stage - Tap 3	Tap 2	5 kW - Tap 1 8 kW - Tap 1 10 kW - Tap 2 15 kW - Tap 2	1750 CFM / 2250 CFM	12x9R Blower 1 HP [746] 5 Speed (Constant Torque)	Tap 1 - FAN	CFM	1101	1051	983	896	825	763	695	621	558	506
							RPM	594	628	668	724	759	790	820	854	888	915
							Watts	130	137	145	157	164	171	177	186	193	197
							CFM	1454	1401	1363	1322	1265	1195	1140	1088	1039	998
							RPM	719	757	787	816	854	898	933	963	985	1005
							Watts	253	264	274	283	296	311	322	332	340	348
	High Stage - Tap 4	Tap 2	5 kW - Tap 1 8 kW - Tap 1 10 kW - Tap 2 15 kW - Tap 2	1750 CFM / 2250 CFM	12x9R Blower 1 HP [746] 5 Speed (Constant Torque)	Tap 3 - Low Stage Cool	CFM	1364	1320	1277	1232	1169	1100	1036	980	930	877
							RPM	687	722	754	784	824	870	907	938	953	984
							Watts	216	227	235	245	257	271	282	290	297	304
							CFM	1870	1832	1792	1761	1731	1696	1656	1621	1582	1528
							RPM	885	912	939	963	987	1009	1034	1057	1083	1113
							Watts	492	506	521	534	545	555	569	581	593	611
High Stage - Tap 4	Tap 2	5 kW - Tap 1 8 kW - Tap 1 10 kW - Tap 2 15 kW - Tap 2	1750 CFM / 2250 CFM	12x9R Blower 1 HP [746] 5 Speed (Constant Torque)	Tap 4 - High Stage Cool ** Med Static	CFM	2152	2120	2087	2059	2025	2004	1969	1934	1905	1875	
						RPM	1002	1025	1051	1074	1090	1111	1136	1152	1175	1197	
						Watts	761	776	791	803	816	828	841	852	865	878	

NOTES:

(1) For constant torque motors: Use motor taps 3-5 to achieve rated airflow at AHRI minimum External Static Pressure.

(a) Use * marked tap for AHRI 210/240-2023

(b) Use ** marked tap for AHRI 210/240-2017

(2) Grayed out portions not recommended for use in field.

DOWN DISCHARGE PRESSURE DROP (ADD TO EXTERNAL STATIC PRESSURE)							
CFM [L/s]	800 [378]	1000 [472]	1200 [566]	1400 [661]	1600 [755]	1800 [849]	2000 [944]
Pressure Drop—Includes W.C. [kPa]	.02 [.005]	.05 [.012]	.07 [.017]	.1 [.025]	.12 [.030]	.15 [.037]	.17 [.042]

[*] Designates Metric Conversions

ELECTRICAL DATA - RACAZR SERIES

		024AJT	030AJT	036ACT	036ADT	036AJT	042ACT	042AJT
Unit Information	Unit Operating Voltage Range	187-253	187-253	187-253	414-506	187-253	187-253	187-253
	Volts	208/230	208/230	208/230	460	208/230	208/230	208/230
	Phase	1	1	3	3	1	3	1
	Hz	60	60	60	60	60	60	60
	Minimum Circuit Ampacity	18	21	20	10	28	22	28
	Minimum Overcurrent Protection Device Size	25	25	25	15	35	25	35
	Maximum Overcurrent Protection Device Size	25	30	25	15	40	30	40
Compressor Motor	No.	1	1	1	1	1	1	1
	Volts	208/230	208/230	208/230	460	208/230	208/230	208/230
	Phase	1	1	3	3	1	3	1
	RPM	3500	3500	3500	3500	3500	3500	3500
	HP, Compressor 1							
	Amps (RLA), Comp. 1	10.8	12.3	8.5	3.8	14.7	10.6	15.9
	Amps (LRA), Comp. 1	55	63	70	31	75	118	112.3
	HP, Compressor 2							
	Amps (RLA), Comp. 2							
Amps (LRA), Comp. 2								
Condenser Motor	No.	1	1	1	1	1	1	1
	Volts	208/230	208/230	208/230	460	208/230	208/230	208/230
	Phase	1	1	1	1	1	1	1
	HP	1/3	1/3	1/3	1/3	1/3	1/3	1/3
	Amps (FLA, each)	1.5	1.5	1.5	0.8	1.5	2	2
	Amps (LRA, each)	3	3	3	1.6	3	3.9	3.9
Evaporator Fan	No.	1	1	1	1	1	1	1
	Volts	208/230	208/230	208/230	460	208/230	208/230	208/230
	Phase	1	1	1	1	1	1	1
	HP	1/3	1/2	1	1	1	3/4	3/4
	Amps (FLA, each)	2.8	4.1	7.6	4	7.6	6	6
	Amps (LRA, each)							

ELECTRICAL DATA - RACAZR SERIES

		048ACT	048ADT	048AJT	060ACT	060ADT	060AJT
Unit Information	Unit Operating Voltage Range	187-253	414-506	187-253	187-253	414-506	187-253
	Volts	208/230	460	208/230	208/230	460	208/230
	Phase	3	3	1	3	3	1
	Hz	60	60	60	60	60	60
	Minimum Circuit Ampacity	26	13	36	29	14	41
	Minimum Overcurrent Protection Device Size	30	15	45	35	15	50
	Maximum Overcurrent Protection Device Size	35	15	50	40	15	60
Compressor Motor	No.	1	1	1	1	1	1
	Volts	208/230	460	208/230	208/230	460	208/230
	Phase	3	3	1	3	3	1
	RPM	3500	3500	3500	3500	3500	3500
	HP, Compressor 1						
	Amps (RLA), Comp. 1	12.6	6	19.9	14	6.5	23.5
	Amps (LRA), Comp. 1	123	60	109	93	60	118
	HP, Compressor 2						
	Amps (RLA), Comp. 2						
Amps (LRA), Comp. 2							
Condenser Motor	No.	1	1	1	1	1	1
	Volts	208/230	460	208/230	208/230	460	208/230
	Phase	1	1	1	1	1	1
	HP	1/3	1/3	1/3	1/2	1/2	1/2
	Amps (FLA, each)	2	1	2	2.3	1.2	2.3
	Amps (LRA, each)	3.9	2.2	3.9	5.5	3	5.5
Evaporator Fan	No.	1	1	1	1	1	1
	Volts	208/230	460	208/230	208/230	460	208/230
	Phase	1	1	1	1	1	1
	HP	1	1	1	1	1	1
	Amps (FLA, each)	7.6	4	8.9	8.9	4	8.9
	Amps (LRA, each)						

208/240 VOLT, THREE PHASE, 60 Hz, AUXILIARY ELECTRIC HEATER KITS CHARACTERISTICS AND APPLICATION									
Single Power Supply for Both Unit and Heater Kit					Separate Power Supply for Both Unit and Heater Kit				
Russell® By Rheem Model Number RACAZR	Heater Kit			Air Conditioner		Heater Kit		Air Conditioner	
	RXQJ- Heater Kit Nominal kW	Rated Heater kW @ 208/240 V	Heater Amp. @ 208/240 V	Unit Min. Ckt. Ampacity @ 208/240 V	Over Current Protective Device Size Min./Max	Min. Ckt. Ampacity 208/240V	Max. Fuse Size 208/240V	Min. Circuit Ampacity 208/240V	Over Current Protective Device Size Min./Max
036ACT000NA HEATER KW	NONE	—	—	20/20	25/25	—	—	20/20	25/25
	A05C	3.8/5	10.4/12	23/25	25/25	13/15	15/15	20/20	25/25
	A08C	5.7/7.6	15.9/18.3	30/33	30/35	20/23	20/25	20/20	25/25
	A10C	7.2/9.6	20/23.1	35/39	35/40	25/29	25/30	20/20	25/25
	A15C	10.8/14.4	30.1/34.7	48/53	50/60	38/44	40/45	20/20	25/25
042ACT000NA HEATER KW	NONE	—	—	22/22	30/30	—	—	22/22	30/30
	A05C	3.8/5	10.4/12	22/23	30/30	13/15	15/15	22/22	30/30
	A08C	5.7/7.6	15.9/18.3	28/31	30/35	20/23	20/25	22/22	30/30
	A10C	7.2/9.6	20/23.1	33/37	35/40	25/29	25/30	22/22	30/30
	A15C	10.8/14.4	30.1/34.7	46/51	50/60	38/44	40/45	22/22	30/30
048ACT000NA HEATER KW	NONE	—	—	26/26	35/35	—	—	26/26	35/35
	A05C	3.8/5	10.4/12	26/26	35/35	13/15	15/15	26/26	35/35
	A08C	5.7/7.6	15.9/18.3	30/33	35/35	20/23	20/25	26/26	35/35
	A10C	7.2/9.6	20/23.1	35/39	35/40	25/29	25/30	26/26	35/35
	A15C	10.8/14.4	30.1/34.7	48/53	50/60	38/44	40/45	26/26	35/35
060ACT000NA HEATER KW	NONE	—	—	29/29	40/40	—	—	29/29	40/40
	A05C	3.8/5	10.4/12	29/29	40/40	13/15	15/15	29/29	40/40
	A08C	5.7/7.6	15.9/18.3	31/34	40/40	20/23	20/25	29/29	40/40
	A10C	7.2/9.6	20/23.1	37/40	40/40	25/29	25/30	29/29	40/40
	A15C	10.8/14.4	30.1/34.7	49/55	50/60	38/44	40/45	29/29	40/40

480 VOLT, THREE PHASE, 60 Hz, AUXILIARY ELECTRIC HEATER KITS CHARACTERISTICS AND APPLICATION									
Single Power Supply for Both Unit and Heater Kit						Separate Power Supply for Both Unit and Heater Kit			
Russell® By Rheem Model Number RACAZR	Heater Kit			Air Conditioner		Heater Kit		Air Conditioner	
	RXQJ- Heater Kit Nominal kW	Rated Heater kW @ 208/240 V	Heater Amp. @ 208/240 V	Unit Min. Ckt. Ampacity @ 208/240 V	Over Current Protective Device Size Min./Max	Min. Ckt. Ampacity 208/240V	Max. Fuse Size 208/240V	Min. Circuit Ampacity 208/240V	Over Current Protective Device Size Min./Max
036ADT000NA HEATER KW	NONE	—	—	10	15	—	—	10	15
	A05D	4.8	5.8	13	15	8	15	10	15
	A08D	7.6	9.1	17	20	12	15	10	15
	A10D	9.6	11.6	20	20	15	15	10	15
	A15D	14.4	17.3	27	30	22	25	10	15
048ADT000NA HEATER KW	NONE	—	—	13	15	—	—	13	15
	A05D	4.8	5.8	13	15	8	15	13	15
	A08D	7.6	9.1	17	20	12	15	13	15
	A10D	9.6	11.6	20	20	15	15	13	15
	A15D	14.4	17.3	27	30	22	25	13	15
060ADT000NA HEATER KW	NONE	—	—	14	15	—	—	14	15
	A05D	4.8	5.8	14	15	8	15	14	15
	A08D	7.6	9.1	17	20	12	15	14	15
	A10D	9.6	11.6	20	20	15	15	14	15
	A15D	14.4	17.3	27	30	22	25	14	15

208/240 VOLT, SINGLE PHASE, 60 Hz, AUXILIARY ELECTRIC HEATER KITS CHARACTERISTICS AND APPLICATION									
Single Power Supply for Both Unit and Heater Kit					Separate Power Supply for Both Unit and Heater Kit				
Rheem Model Number RACAZR	Heater Kit			Air Conditioner		Heater Kit		Air Conditioner	
	RXQJ-Heater Kit Nominal kW	Rated Heater kW @ 208/240 V	Heater Amp. @ 208/240 V	Unit Min. Ckt. Ampacity @ 208/240 V	Over Current Protective Device Size Min./Max	Min. Ckt. Ampacity 208/240V	Max. Fuse Size 208/240V	Min. Circuit Ampacity 208/240V	Over Current Protective Device Size Min./Max
024AJT000NA HEATER KW	NONE	—	—	18/18	25/25	—	—	18/18	25/25
	A05J	3.6/4.8	17.3/20	26/29	30/30	22/25	25/25	18/18	25/25
	A08J	5.7/7.6	27.4/31.6	38/43	40/45	35/40	35/40	18/18	25/25
	A10J	7.2/9.6	34.6/40	47/54	50/60	44/50	45/50	18/18	25/25
030AJT000NA HEATER KW	NONE	—	—	21/21	30/30	—	—	21/21	30/30
	A05J	3.6/4.8	17.3/20	27/31	30/35	22/25	25/25	21/21	30/30
	A08J	5.7/7.6	27.4/31.6	40/45	40/45	35/40	35/40	21/21	30/30
	A10J	7.2/9.6	34.6/40	49/56	50/60	44/50	45/50	21/21	30/30
036AJT000NA HEATER KW	NONE	—	—	28/28	40/40	—	—	28/28	40/40
	A05J	3.6/4.8	17.3/20	32/35	40/40	22/25	25/25	28/28	40/40
	A08J	5.7/7.6	27.4/31.6	44/49	45/50	35/40	35/40	28/28	40/40
	A10J	7.2/9.6	34.6/40	53/60	60/60	44/50	45/50	28/28	40/40
	A15J	10.8/14.4	51.9/60	75/85	80/90	65/75	70/80	28/28	40/40
042AJT000NA HEATER KW	NONE	—	—	28/28	40/40	—	—	28/28	40/40
	A05J	3.6/4.8	17.3/20	30/33	40/40	22/25	25/25	28/28	40/40
	A08J	5.7/7.6	27.4/31.6	42/47	45/50	35/40	35/40	28/28	40/40
	B10J	7.2/9.6	34.6/40	51/58	60/60	44/50	45/50	28/28	40/40
	B15J	10.8/14.4	51.9/60	73/83	80/90	65/75	70/80	28/28	40/40
048AJT000NA HEATER KW	NONE	—	—	36/36	50/50	—	—	36/36	50/50
	A05J	3.6/4.8	17.3/20	36/37	50/50	22/25	25/25	36/36	50/50
	A08J	5.7/7.6	27.4/31.6	46/51	50/60	35/40	35/40	36/36	50/50
	B10J	7.2/9.6	34.6/40	55/62	60/70	44/50	45/50	36/36	50/50
	B15J	10.8/14.4	51.9/60	76/87	80/90	65/75	70/80	36/36	50/50
060AJT000NA HEATER KW	NONE	—	—	41/41	60/60	—	—	41/41	60/60
	A05J	3.6/4.8	17.3/20	41/41	60/60	22/25	25/25	41/41	60/60
	A08J	5.7/7.6	27.4/31.6	46/51	60/60	35/40	35/40	41/41	60/60
	B10J	7.2/9.6	34.6/40	55/62	60/70	44/50	45/50	41/41	60/60
	B15J	10.8/14.4	51.9/60	76/87	80/90	65/75	70/80	41/41	60/60

UNIT DIMENSIONS PACKAGED AIR CONDITIONERS

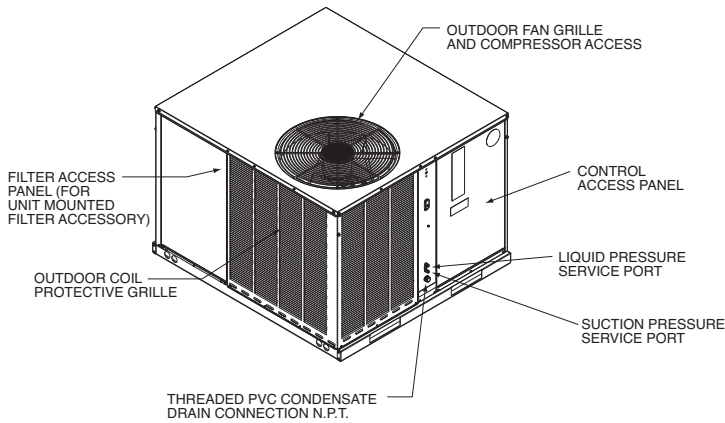

IMPORTANT: UNIT MUST BE LEVEL TO PREVENT WATER MIGRATION

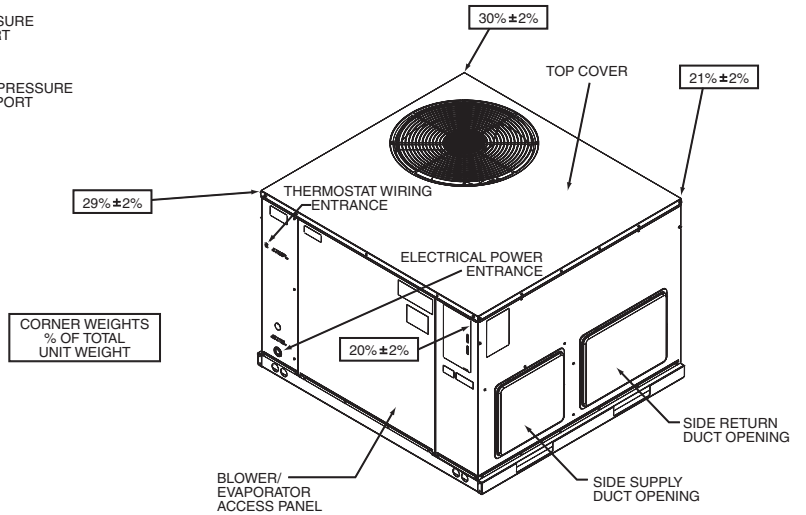

TOP VIEW

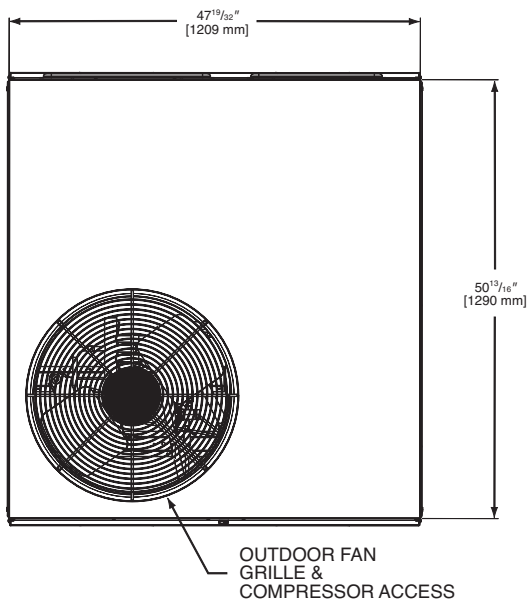

BOTTOM VIEW

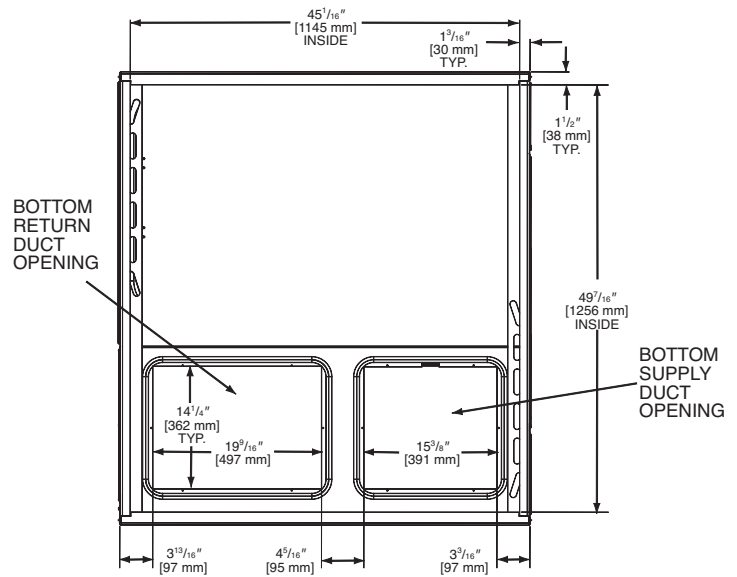

[] Designates Metric Conversions

SIDE VIEW

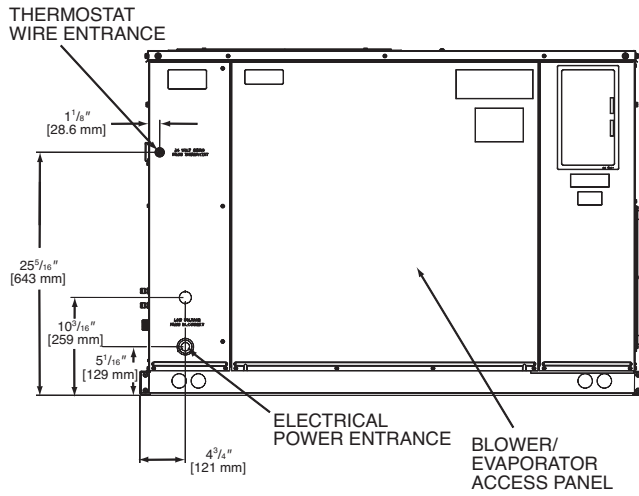

SIDE VIEW

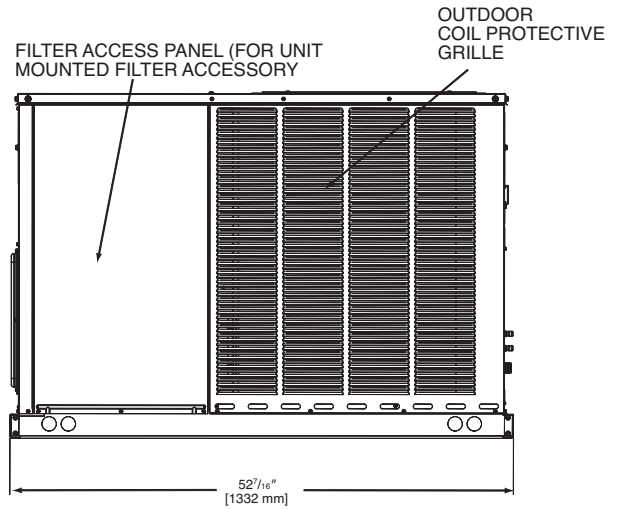

FRONT VIEW

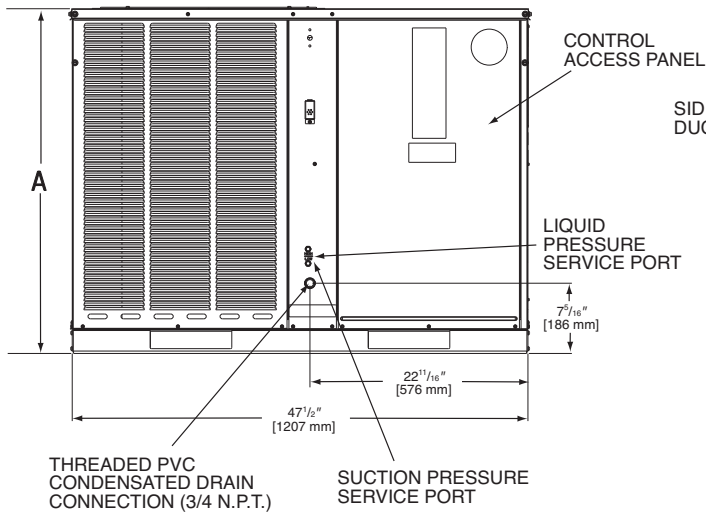

REAR VIEW

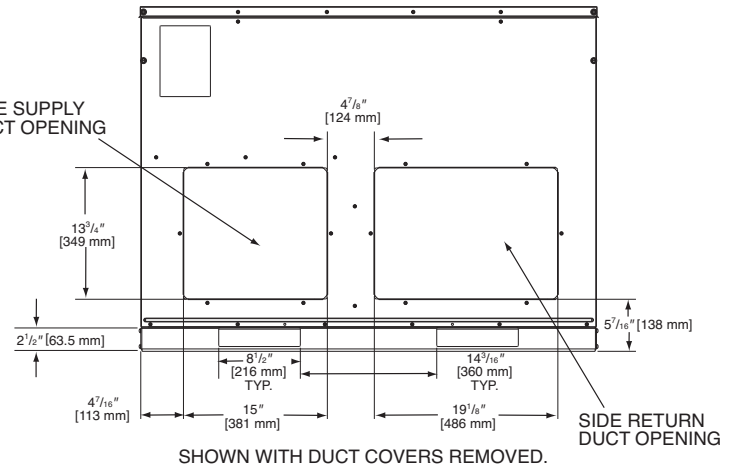

[] Designates Metric Conversions

Model #	Height "A"
024, 030, 036	$35\frac{15}{16}$
042, 048, 060	41

IMPORTANT:
Unit must be level to prevent water migration.

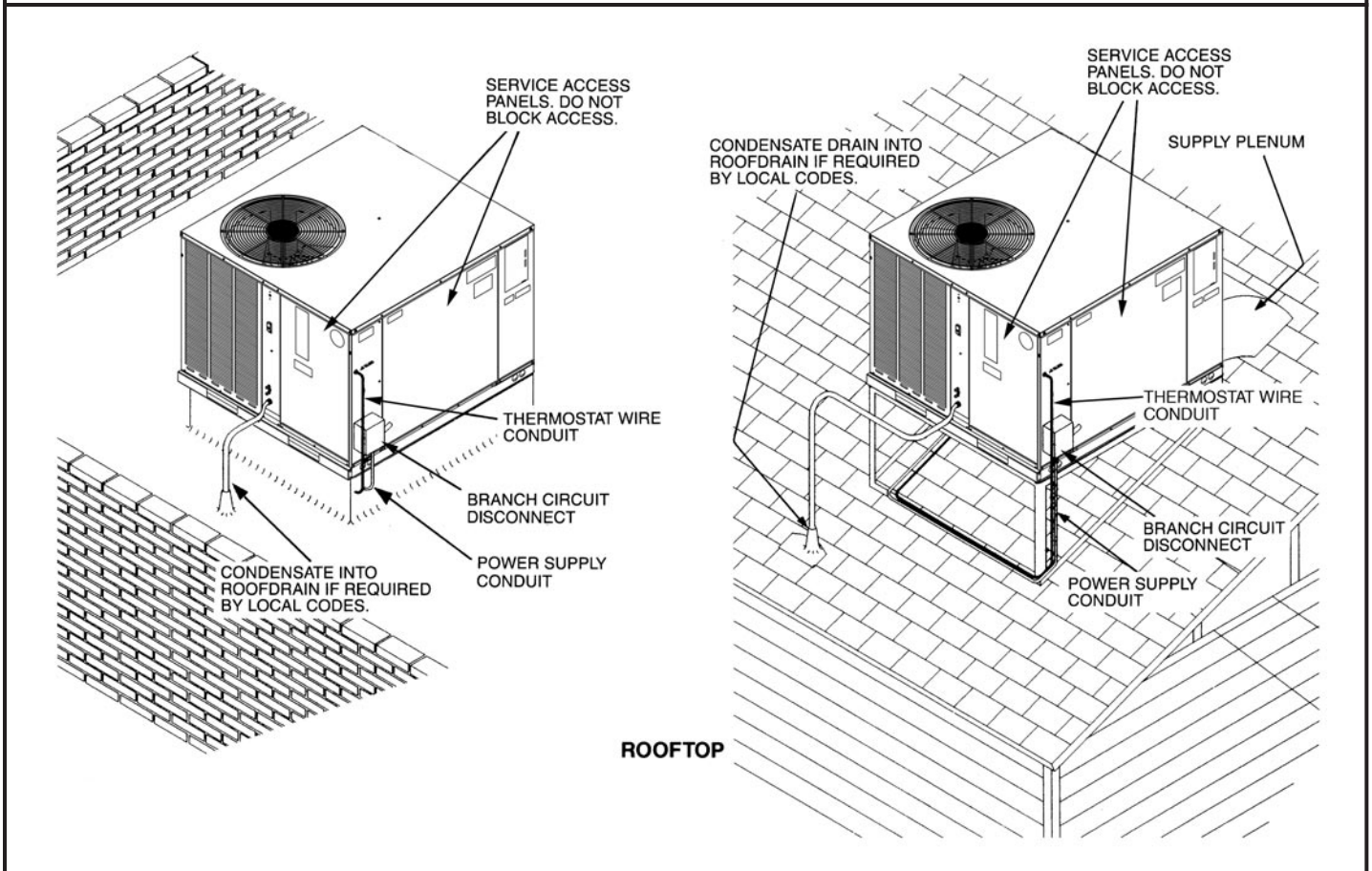
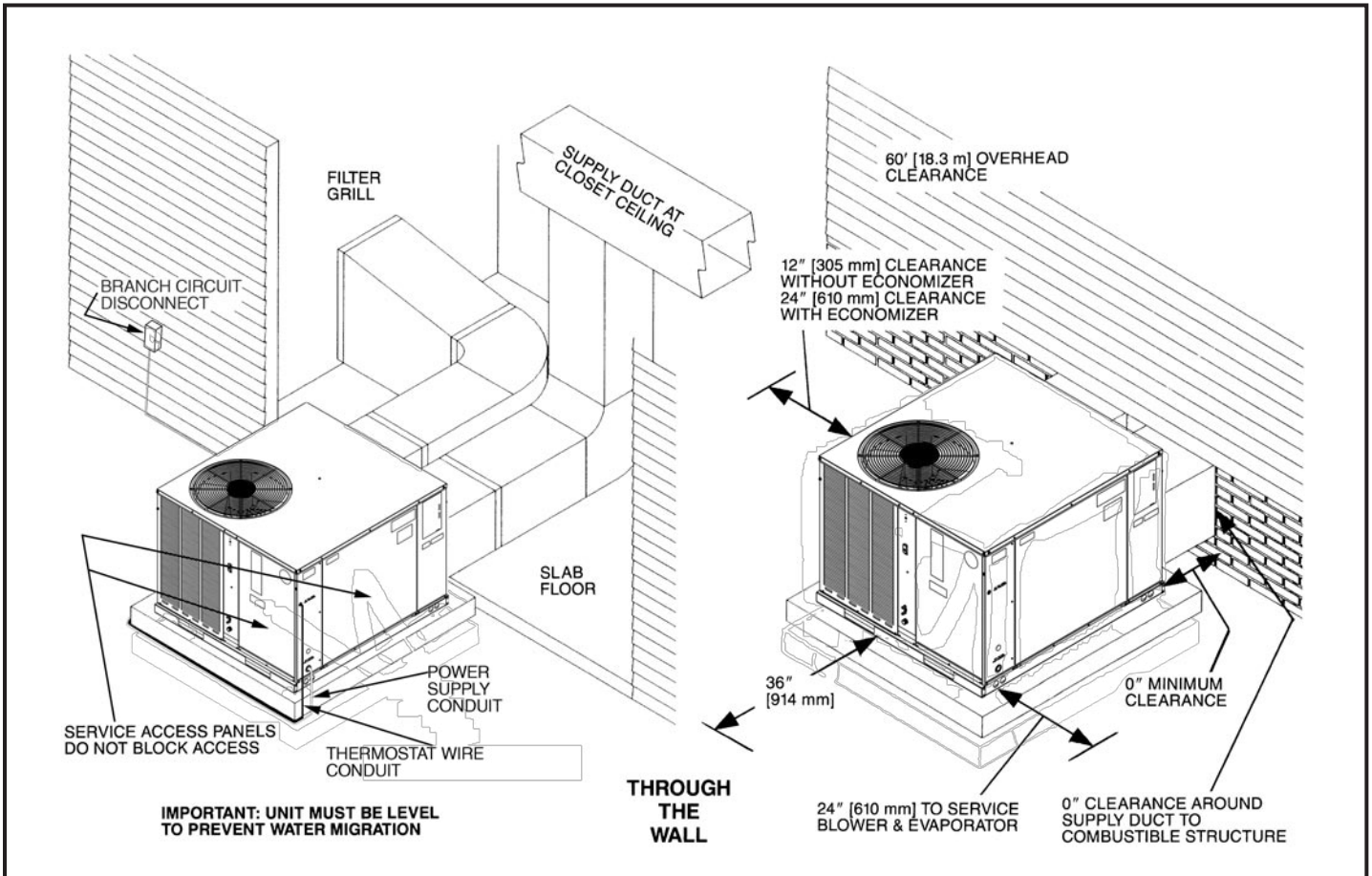

[] Designates Metric Conversions

ACCESSORY EQUIPMENT

Accessory Description	Model Application	Accessory Model No.
Roofcurbs	RACAZR	RXSG-AAA08 (8" [203 mm] Height) RXSG-AAA14 (14" [356 mm] Height)
Supply & Return Diffusers	RACAZR	RXRN-BD15
Economizers (Convertible)	RACAZR	AXRD-01RACAM3
Fresh Air Damper	RACAZR	AXRF-FAB1 (Motorized-35%) AXRF-FAA1 (Fixed-35%)
Rectangular to Round Transition (Downflow)	RACAZR	RXMC-CA02 (16" [406 mm] Ducts) RXMC-CA03 (18" [457 mm] Ducts)
Filter Kit	RACAZR	RXRY-B01
Sideflow Rectangular to Round Transition	RACAZR	AXMC-BA01
Low Ambient Control	RACAZR	RXRZ-B01
High Pressure Control ①	RACAZR	RXAB-E01
Low Pressure Control ②	RACAZR	RXAC-C01

① High pressure switch standard on RACAZR

[] Designates Metric Conversions

COMMON SUPPLY/RETURN CONCENTRIC AIR DIFFUSER

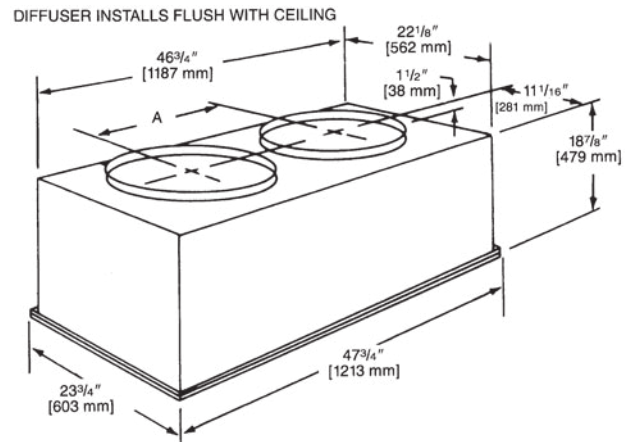
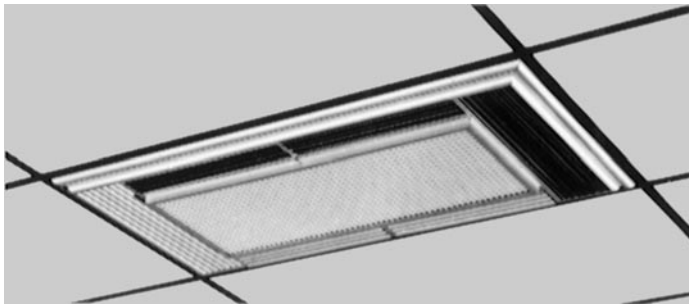

SUPPLY/RETURN DIFFUSER

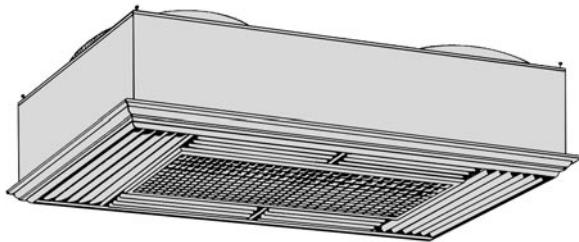

Designed to convert a side by side or an over and under arrangement into a concentric distribution of air. The diffuser is flush mounted, completely insulated, assembled, and internally baffled to provide four way supply air distribution with a center return. To make the assembly complete and ready to fit into a 2' [0.61 m] x 4' [1.22 m] suspended ceiling grid, the diffuser includes adjustable supply louvers, hanging rings, anti-sweat gasket, and round flanges for use with flexible ducts.

Model No.	Diameter Inches [mm]	Shipping Wt. Lbs. [kg]	Dimension A Inches [mm]
RXRN-BD15	16 [406]	90 [40.82]	20 1/2 [521]

NOTE: The location of the combination supply and return diffuser should not exceed 10 feet [3.05 m] above the floor level for units @ 1000 CFM [472 L/s] or less and 12 [3.66 m] to 14 feet [4.27 m] above the floor level for units with CFM greater than 1000 [472 L/s]. If the diffuser is installed with a greater distance than recommended above, the supply air may become stratified above the required comfort area causing uncomfortable conditions.

AIRFLOW/PRESSURE DROP INFORMATION (INCHES W.C. [kPa])

Accessory	Approximate CFM [L/s]-Supply Air			
	1300 [614]	1575 [743]	1800 [850]	2200 [1038]
Plenum & Supply/Return Duct	.07 [.017]	.10 [.024]	.12 [.030]	.17 [.042]
Diffuser	.09 [.022]	.13 [.032]	.16 [.040]	.24 [.060]
Economizer	.06 [.015]	.09 [.022]	.11 [.027]	.17 [.042]

SUPPLY AIR/PERFORMANCE

Diffuser Airflow CFM [L/s]	Range of Throw Ft. [m]
800 [378]-1200 [566]	14 [4.27]-16 [4.88]
1600 [755]-2000 [944]	18 [5.49]-28 [8.53]

FILTER KIT INSTALLATION RXRY-B01

For use in either vertical
or horizontal discharge.

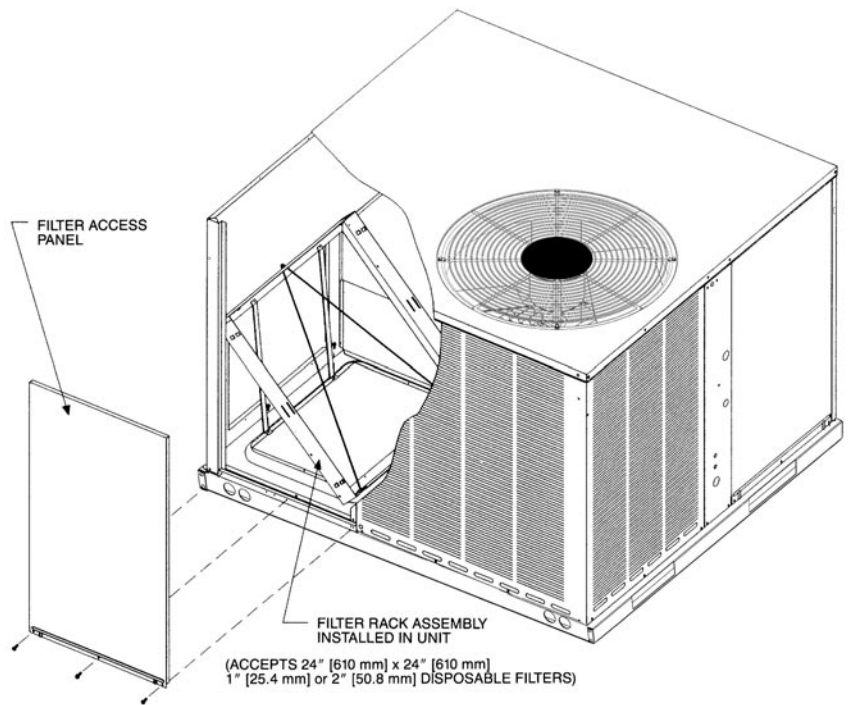

Airflow Pressure Drop, Inches W.C. [kPa]		
CFM [L/s]	1" Filter	2" Filter
500 [236]	.02 [.0050]	.03 [.0075]
600 [283]	.02 [.0050]	.03 [.0075]
700 [330]	.03 [.0075]	.04 [.0101]
800 [378]	.04 [.0101]	.05 [.0124]
900 [425]	.05 [.0124]	.06 [.0149]
1000 [472]	.07 [.0174]	.08 [.0199]
1100 [519]	.08 [.0199]	.09 [.0224]
1200 [566]	.10 [.0249]	.12 [.0299]
1300 [614]	.13 [.0324]	.15 [.0373]
1400 [661]	.16 [.0398]	.19 [.0473]
1500 [708]	.19 [.0473]	.21 [.0523]
1600 [755]	.20 [.0498]	.23 [.0572]
1700 [802]	.21 [.0523]	.24 [.0598]
1800 [850]	.22 [.0548]	.25 [.0623]
1900 [897]	.24 [.0598]	.27 [.0672]
2000 [944]	.26 [.0647]	.29 [.0722]

[] Designates Metric Conversions

DUCT ADAPTERS RECTANGULAR TO ROUND TRANSITIONS (DOWNFLOW)

RXMC-CA02

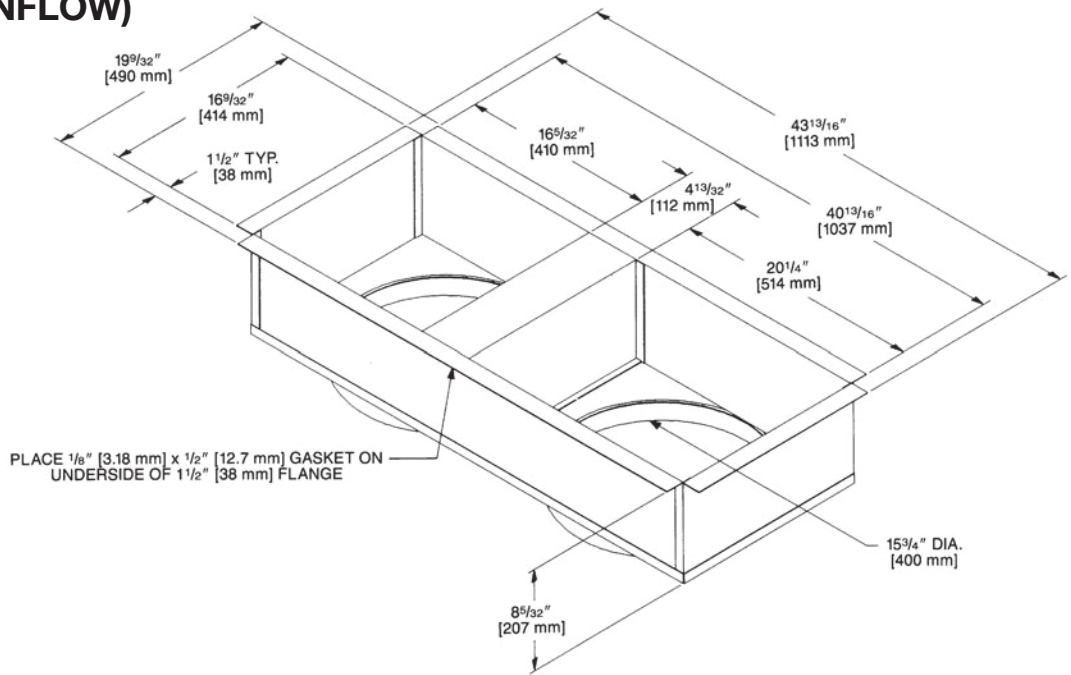

RXMC-CA03

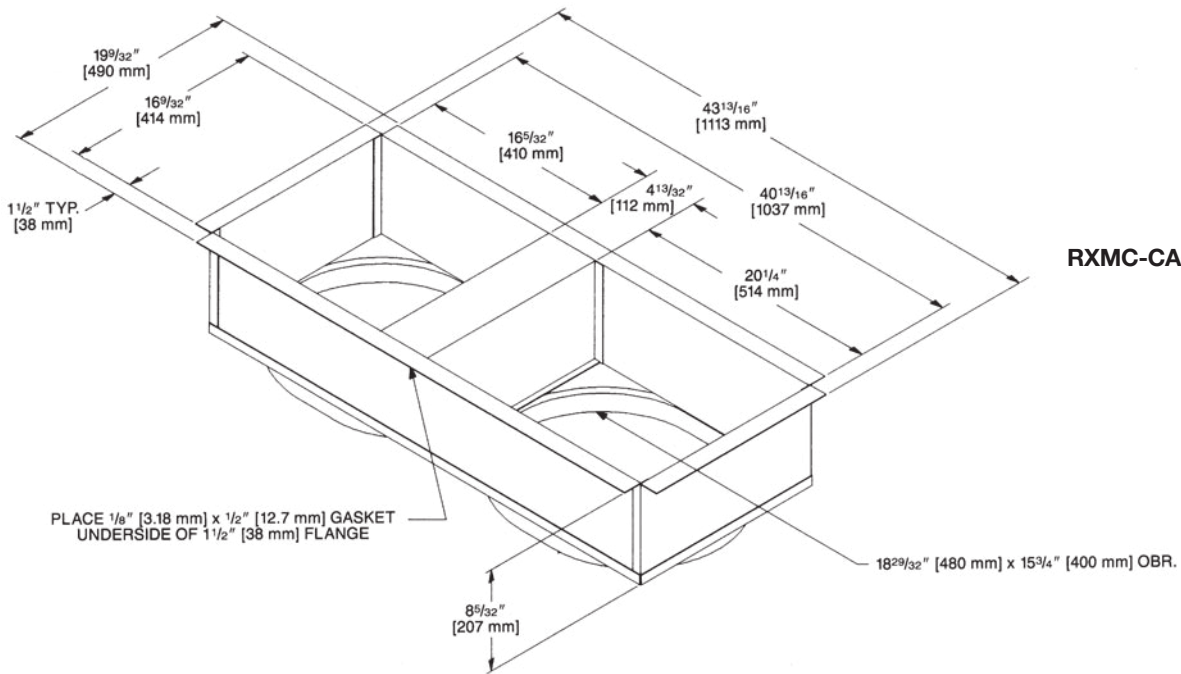

[] Designates Metric Conversions

FRESH AIR DAMPER FOR USE ON RACAZR SERIES

AXRF-FAA1 (Fixed - 0-35%)

The 0-35% manual outside Air Damper is designed to replace the unit return air duct cover. No drilling or damper assembly is required. The amount of outside air (0-35%) is controlled by simply adjusting the side damper.

AXRF-FAB1 (Motorized - 0-35%)

The 0-35% motorized outside Air Damper is designed to replace the unit return air duct cover. No drilling or damper assembly is required. The control motor opens the adjustable slide damper when the unit blower motor is energized.

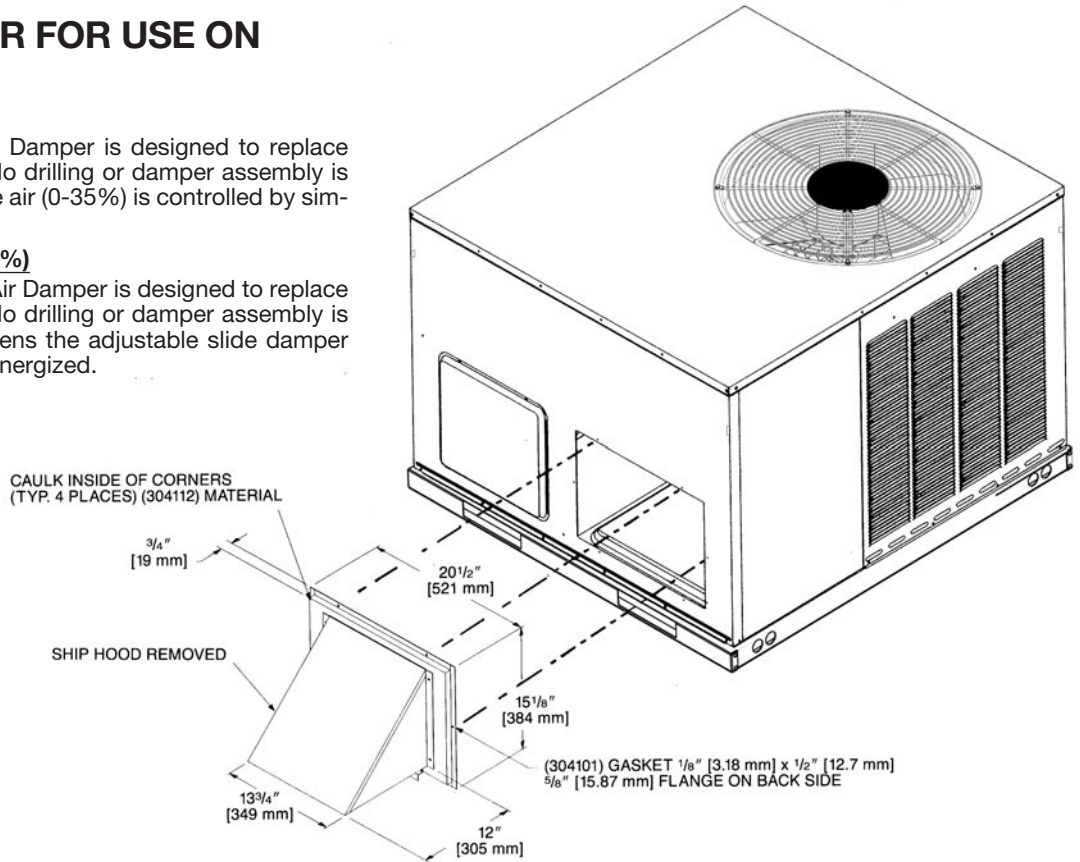

[] Designates Metric Conversions

DUCT ADAPTER SIDEFLOW SQUARE TO ROUND TRANSITION AXMC-BA01

Adapts the side rectangular supply and return openings to 14" [356 mm] diameter round openings. Adapters provided with same finish as unit and also provided with thermal insulation.

[] Designates Metric Conversions

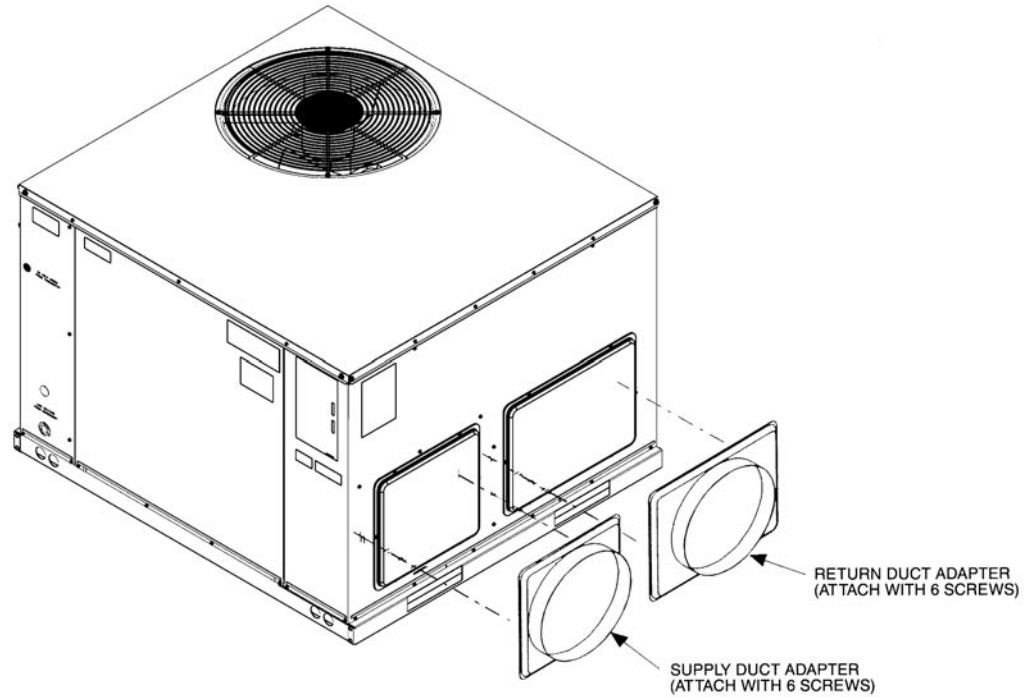

ROOFCURB (Full Perimeter)
RXSG-AAA08, RXSG-AAA14
for RACA- Series

Hinged corners make for fast, easy set-up.

RXSG-AAA08
(8" [203 mm] High)

NOT for use with RQKA/RQLA/RQMA Packaged Heat Pumps.

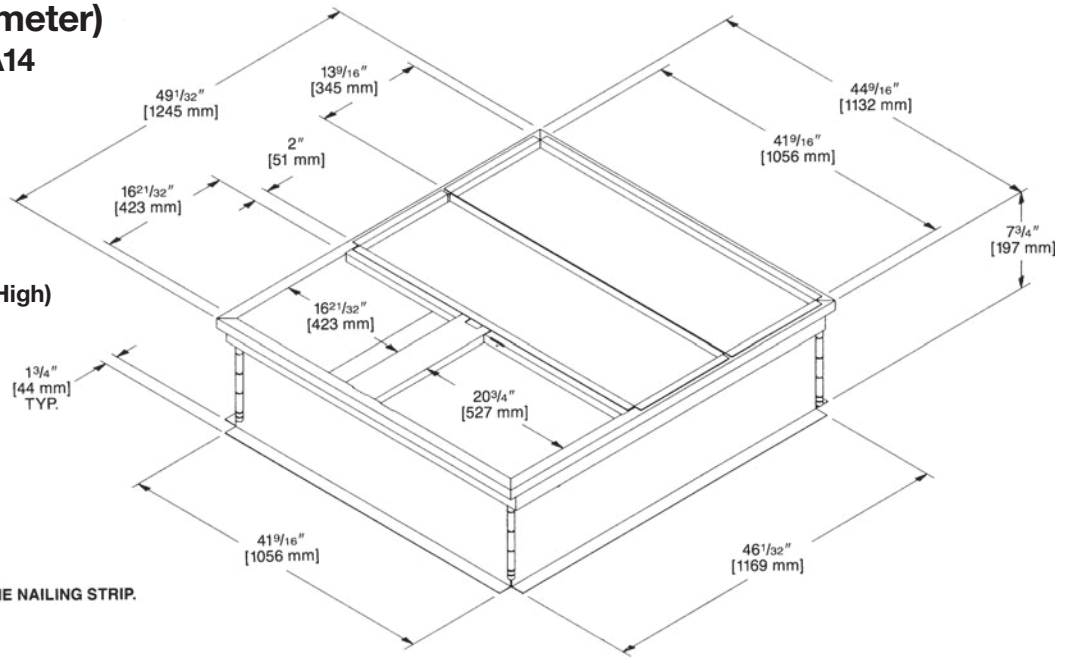

NOTE: PERIMETER OF ROOFCURB IS SUPPLIED WITH A NOMINAL 1" [25.4 mm] x 4" [102 mm] PINE NAILING STRIP.

RXSG-AAA14
(14" [356 mm] High)

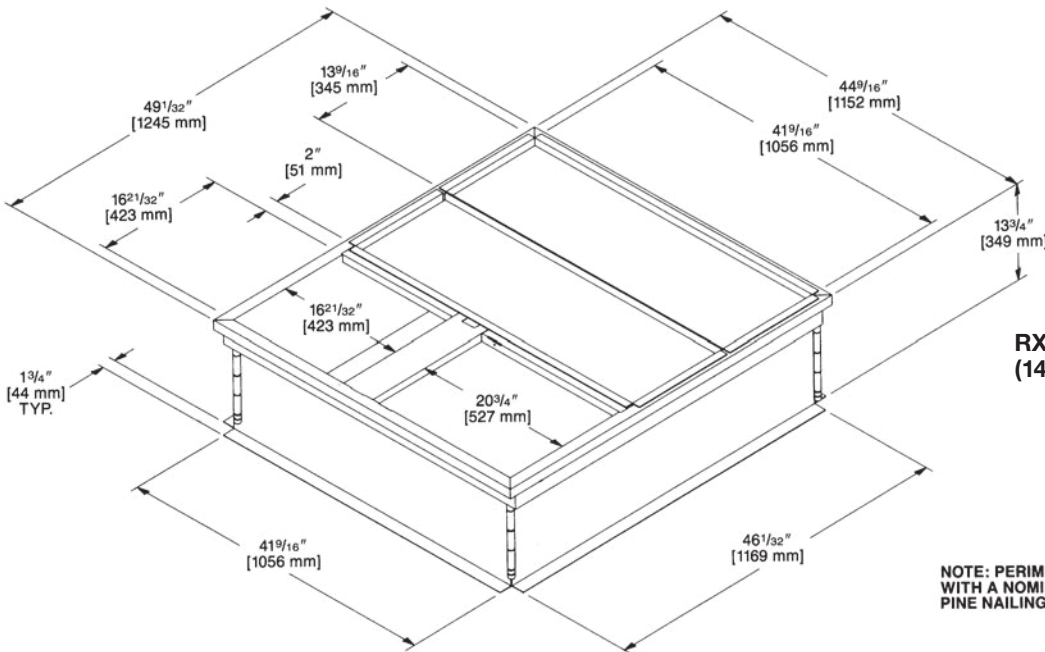

NOTE: PERIMETER OF ROOFCURB IS SUPPLIED WITH A NOMINAL 1" [25.4 mm] x 4" [102 mm] PINE NAILING STRIP.

[] Designates Metric Conversions

PACKAGED AIR CONDITIONERS & GAS/ELECTRIC PACKAGED UNITS ROOFCURB INSTALLATION (Full Perimeter)

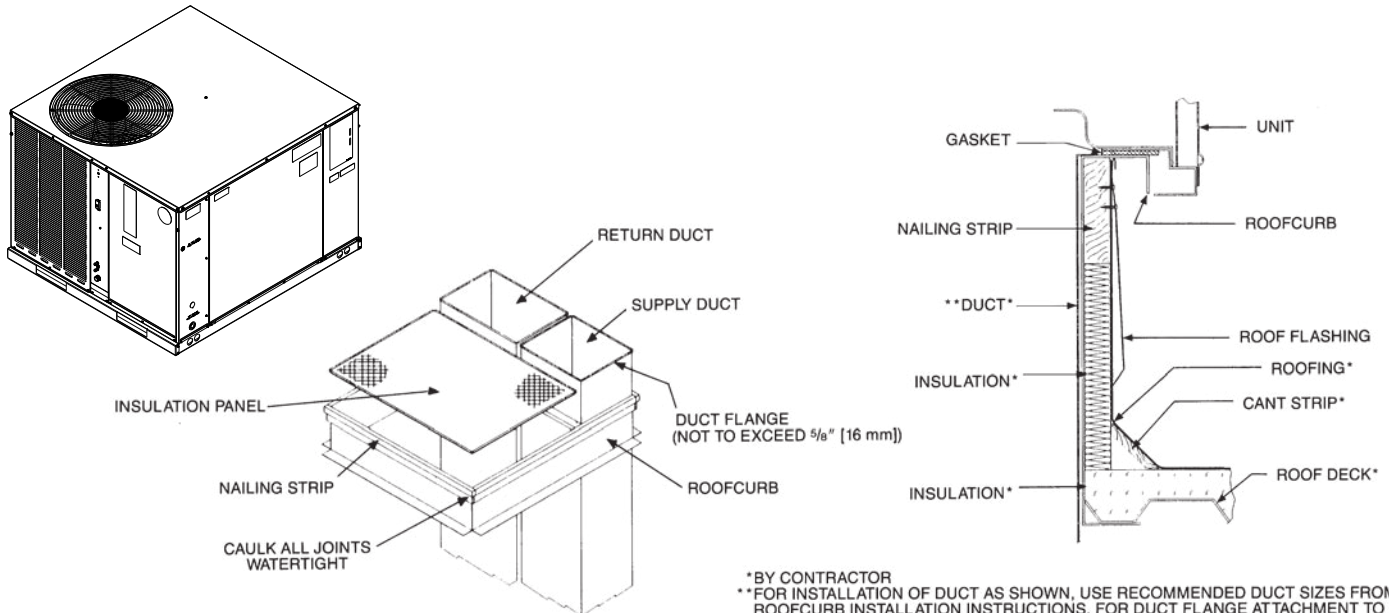

[] Designates Metric Conversions

ROOFCURB ADAPTERS

Fabricated from galvanized steel to adapt the New cabinet to the old style curb. All are furnished with a New gasket.

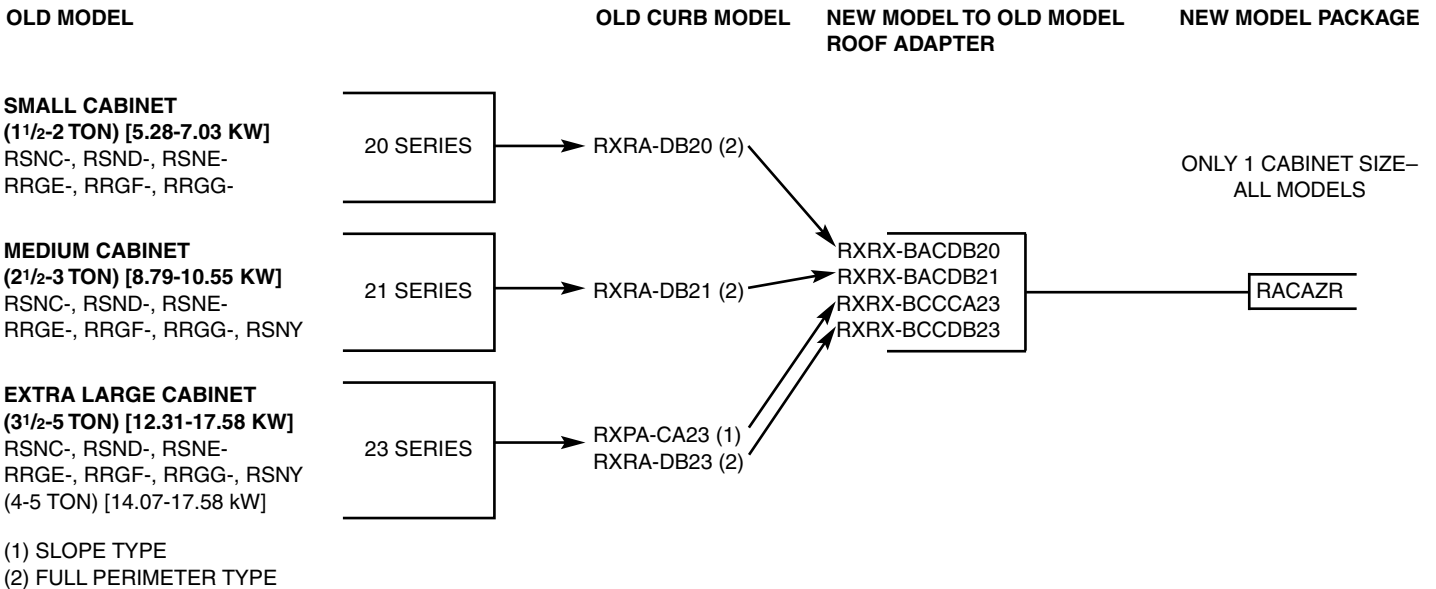

ELECTRIC HEATER KITS—RACAZR

ELECTRIC HEATER KIT MODELS	UNIT MODEL APPLICATION (13.4 SEER2 RACAZR)
RXQJ-A05J (208-240 volt, 1-ph, 5kw)	024/030/036/042/048/060*J
RXQJ-A08J (208-240 volt, 1-ph, 8kw)	024/030/036/042/048/060*J
RXQJ-A10J (208-240 volt, 1-ph, 10kw)	024/030/036*J
RXQJ-A15J (208-240 volt, 1-ph, 15kw)	036*J
RXQJ-B10J (208-240 volt, 1-ph, 10kw)	042/048/060*J
RXQJ-B15J (208-240 volt, 1-ph, 15kw)	042/048/060*J
RXQJ-A05C (208-240 volt, 3-ph, 10kw)	036/042/048/060*C
RXQJ-A08C (208-240 volt, 3-ph, 15kw)	036/042/048/060*C
RXQJ-A10C (208-240 volt, 3-ph, 10kw)	036/042/048/060*C
RXQJ-A15C (208-240 volt, 3-ph, 15kw)	036/042/048/060*C
RXQJ-A05D (208-240 volt, 3-ph, 10kw)	036/048/060*D
RXQJ-A08D (208-240 volt, 3-ph, 15kw)	036/048/060*D
RXQJ-A10D (208-240 volt, 3-ph, 10kw)	036/048/060*D
RXQJ-A15D (208-240 volt, 3-ph, 15kw)	036/048/060*D

WARNING

ONLY ELECTRIC HEATER KITS SUPPLIED BY THIS MANUFACTURER AS DESCRIBED IN THIS PUBLICATION HAVE BEEN DESIGNED, TESTED, AND EVALUATED BY A NATIONALLY RECOGNIZED SAFETY TESTING AGENCY FOR USE WITH THIS UNIT. USE OF ANY OTHER MANUFACTURED ELECTRIC HEATERS INSTALLED WITHIN THIS UNIT MAY CAUSE HAZARDOUS CONDITIONS RESULTING IN PROPERTY DAMAGE, FIRE, BODILY INJURY OR DEATH.

BEFORE PURCHASING THIS APPLIANCE, READ IMPORTANT ENERGY COST AND EFFICIENCY INFORMATION AVAILABLE FROM YOUR RETAILER.

GENERAL TERMS OF LIMITED WARRANTY*

Rheem® will furnish a replacement for any part of this product which fails in normal use and service within the applicable periods stated, in accordance with the terms of the limited warranty.

***For complete details of the Limited and Conditional Warranties, including applicable terms and conditions, contact your local contractor or the Manufacturer for a copy of the product warranty certificate.**

Conditional Parts (Registration Required)

1 Phase, Residential Applications.....Ten (10) Years

Compressor

1 Phase, Residential Applications.....Ten (10) Years

1 & 3 Phase, Commercial ApplicationsFive (5) Years

Parts

1 & 3 Phase, Commercial Applications.....One (1) Year

© 2024 Rheem Manufacturing Company. Russell By Rheem trademarks owned by Rheem Manufacturing Company.

In keeping with its policy of continuous progress and product improvement, Russell by Rheem reserves the right to make changes without notice.



Russell® By Rheem

5600 Old Greenwood Road, Fort Smith, AR 72908

Before proceeding with installation, refer to installation instructions packaged with each model, as well as complying with all Federal, State, Provincial, and Local codes, regulations, and practices.