



Endeavor® Line Achiever® Series Gas Furnaces



R801T Ultra Low NOx

80% A.F.U.E.†

Heating Stages: Single Stage

Motor Type: Constant Torque

Input Rates: 50 to 100 kBTU [14.7 to 29.3 kW]

Configuration Options: Upflow/Horizontal



† A.F.U.E. (Annual Fuel Utilization Efficiency) calculated in accordance with Department of Energy test procedures.

Table of Contents

Features and Benefits	3
Model Number Identification	4
Physical Data and Specifications	5
Dimensional Data	6-7
Blower Performance Data	8
Accessories	9
Limited Warranty	10

Features and Benefits

- **Ultra Low Greenhouse Gas Emissions:** Certified unit meets 14ng/j NOx emission standard – reducing NOx emissions by 65%
- **PlusOne® Diagnostics:** 7 Segment LED all units
- **PlusOne Ignition System:** Proven Direct Spark Ignition (DSI) for reliability and longevity
- **Low profile, 34-inch Cabinet:** Makes our furnaces ideal for space-constrained installations
- **Hemmed Cabinet & Door Edges and Quarter-Turn Door Fasteners:** Allows for safe, tool-less access and serviceability
- **Removable Heat Exchanger:** Aluminized steel construction provides maximum corrosion resistance and thermal fatigue reliability
- **Blower Shelf Design:** Ensures serviceability in all furnace orientations
- **Cabinet Air Leakage:** Less than 2% at 1-inch H₂O when tested in accordance with ASHRAE Standard 193

Gas Furnaces

<u>R</u>	<u>80</u>	<u>1</u>	<u>T</u>	<u>050</u>	<u>3</u>	<u>A</u>	<u>17</u>	<u>UH</u>	<u>U</u>	<u>N</u>	<u>A</u>	<u>P</u>
Brand	Furnace Efficiency	Stages of Heating	Motor Type	Heating Input	AC Max. Capacity	Major Series	Width	Position	NOx	Controls	Minor Series	Option Code
R - Ruud	80 - 80% AFUE	1 - Single Stage	T - Constant Torque	050 - 50K BTUH [14.7 kW] 070 - 70K BTUH [20.5 kW] 100 - 100K BTUH [29.3 kW]	3 - 3 ton drive 4 - 4 ton drive 5 - 5 ton drive	A - 1st Design Series	17 - 17.5" Width 21 - 21" Width	UH - Upflow Horizontal	U - Ultra Low NOx	N - Non-Comm.	A - 1st Series	P - Premium Grade

[] Designates Metric Conversions

AVAILABLE MODELS
R801T0503A17UHUNAP
R801T0504A17UHUNAP
R801T0703A17UHUNAP
R801T0704A17UHUNAP
R801T1004A21UHUNAP
R801T1005A21UHUNAP

STANDARD EQUIPMENT
100% Safety Lock Out
7 Segment LED
Primary aluminized steel heat exchanger
Blower Compartment Door Safety Switch
Completely Assembled and Wired
Cool Fan Off Delay
Direct Drive Motor
Electronic Air Cleaner Connections
Field Selectable Heat Fan Off Delay
Flame Sense Current Diagnostics
Fully Insulated Heat Exchanger Cabinet
Humidifier Connections
Limit Controls
Low Speed Continuous Fan Option
Manual Shut-Off Valve
Multi-Speed Constant Torque Blower Motor
One Hour Automatic Retry
Power and Self-Test Diagnostics
Pressure Switch
Redundant Main Gas Control
Single Speed Option for Heating and Cooling Applications
Solid Bottom
Blower Insulation
Solid State Time On/Off Blower Control
Transformer
Variable Speed 3 Phase Induced Draft Motor
3 way multi poise design Upflow/Horizontal

WARNING
 THIS FURNACE IS NOT APPROVED
 OR RECOMMENDED
 FOR USE IN MOBILE HOMES

Physical Data and Specifications—Upflow Models

MODEL NUMBERS R801T SERIES	R801T0503 A17UHUNAP	R801T0504 A17UHUNAP	R801T0703 A17UHUNAP	R801T0704 A17UHUNAP	R801T1004 A21UHUNAP	R801T1005 A21UHUNAP
Input-BTU/Hr [kW] ②	50,000 [14.6]	50,000 [14.6]	70,000 [20.5]	70,000 [20.5]	100,000 [29]	100,000 [29]
Heating Capacity BTU/Hr [kW] ①	40,000 [11.7]	40,000 [11.7]	56,000 [16.4]	56,000 [16.4]	80,000 [23.4]	80,000 [23.4]
Heat Ext. Static Pressure [kPa]	.18 [.05]	.18 [.05]	.20 [.05]	.20 [.05]	.28 [.07]	.28 [.07]
Blower (D x W) [mm]	11 x 6 [279 x 152]	11 x 6 [279 x 152]	11 x 7 [279 x 178]	11 x 7 [279 x 178]	11 x 10 [279 x 254]	11 x 10 [279 x 254]
Motor H.P.—Speed— Type [W]	1/2-5 Spd Constant Torque [373]	3/4-5 Spd Constant Torque [560]	1/2-5 Spd Constant Torque [373]	3/4-5 Spd Constant Torque [560]	3/4-5 Spd Constant Torque [560]	1-5 Spd Constant Torque [746]
Min. Circuit Ampacity	10	11	9	12	13	16
Min. Overload Protection Device	15	15	15	15	15	20
Max. Overload Protection Device	15	15	15	15	20	25
Heating Speed	Low	Low	Med	Med	Med	Med
Cooling Speed	Med-High	High	High	High	High	High
Cooling CFM @ Rating Point [L/s]	1,139 [538]	1,431 [675]	1,135 [536]	1,602 [756]	1,714 [809]	1,979 [934]
Max. E.S.P. (In. W.C.) [kPa]	0.9 [.22]	0.9 [.22]	0.9 [.22]	0.9 [.22]	0.9 [.22]	0.9 [.22]
Temperature Rise Range °F [°C]	35-65 [19.4-36.1]	35-65 [19.4-36.1]	35-65 [19.4-36.1]	35-65 [19.4-36.1]	35-65 [19.4-36.1]	35-65 [19.4-36.1]
Max. Outlet Air Temp. °F [°C]	180 [82.2]	180 [82.2]	180 [82.2]	180 [82.2]	180 [82.2]	180 [82.2]
Approx. Shipping Weight (Lbs.) [kg]	125 [57]	125 [57]	125 [57]	125 [57]	140 [64]	140 [64]
AFUE ①	80.0%	80.0%	80.0%	80.0%	80.0%	80.0%

NOTES: All models are 115V, 60HZ, 1 Ph. Gas connection size for all models is 1/2" [12 mm] N.P.T.

① In accordance with D.O.E. test procedures.

② See Conversion Kit Index Form for high altitude derate.

This furnace is to be installed for natural gas only in air districts requiring 14 ng/J NOx emission limits.

[] Designates Metric Conversions

Upflow Application

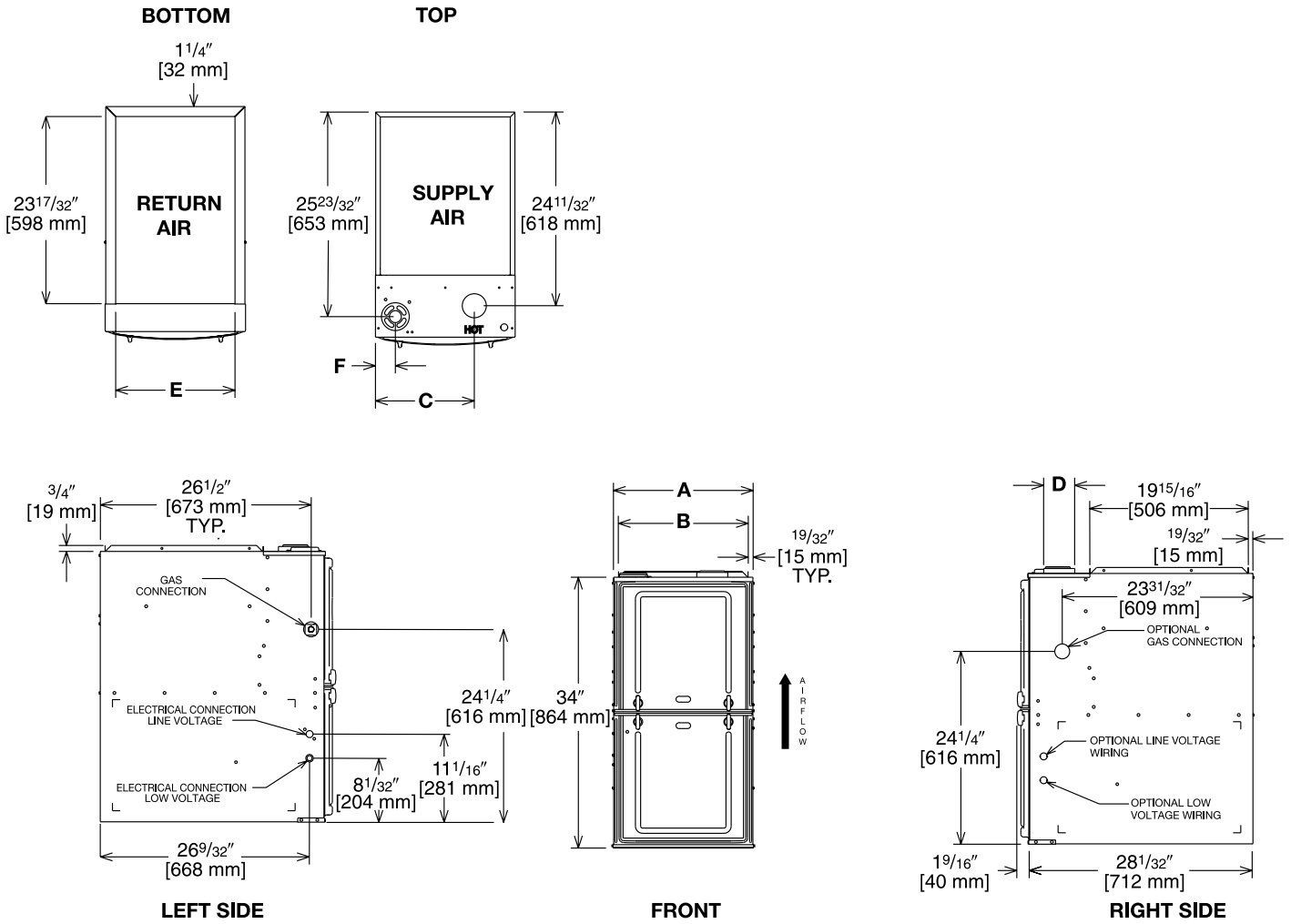

Illustration
ST-A1220-04-00
FIGURE 1

Dimensional Data: Upflow Model

MODEL R801T-	A	B	C	D	E	F	MINIMUM CLEARANCE (IN.) [mm]						SHIP WGTS. (LBS.) [kg]
							LEFT SIDE	RIGHT SIDE	BACK	TOP	FRONT	VENT	
050/070	17 1/2 [445]	16 11/32 [415]	12 3/8 [314]	①	15 [381]	2 1/2 [64]	0	3 [76] ②	0	1 [25]	3 [76]	6 [152] ③	125 [57]
100	21 [533]	19 27/32 [504]	14 1/8 [359]	①	18 1/2 [470]	2 1/2 [64]	0	0	0	1 [25]	3 [76]	6 [152] ③	140 [64]

NOTES: ① May require a 3" [76 mm] to 4" [102 mm] or 3" [76 mm] to 5" [127 mm] adapter.

② May be 0" [0 mm] with type B vent.

③ May be 1" [25 mm] with type B vent.

Furnaces must be vented in accordance with the National Fuel Gas Code, ANSI Z223.1 and in accordance with local codes.

[] Designates Metric Conversions

Horizontal Application

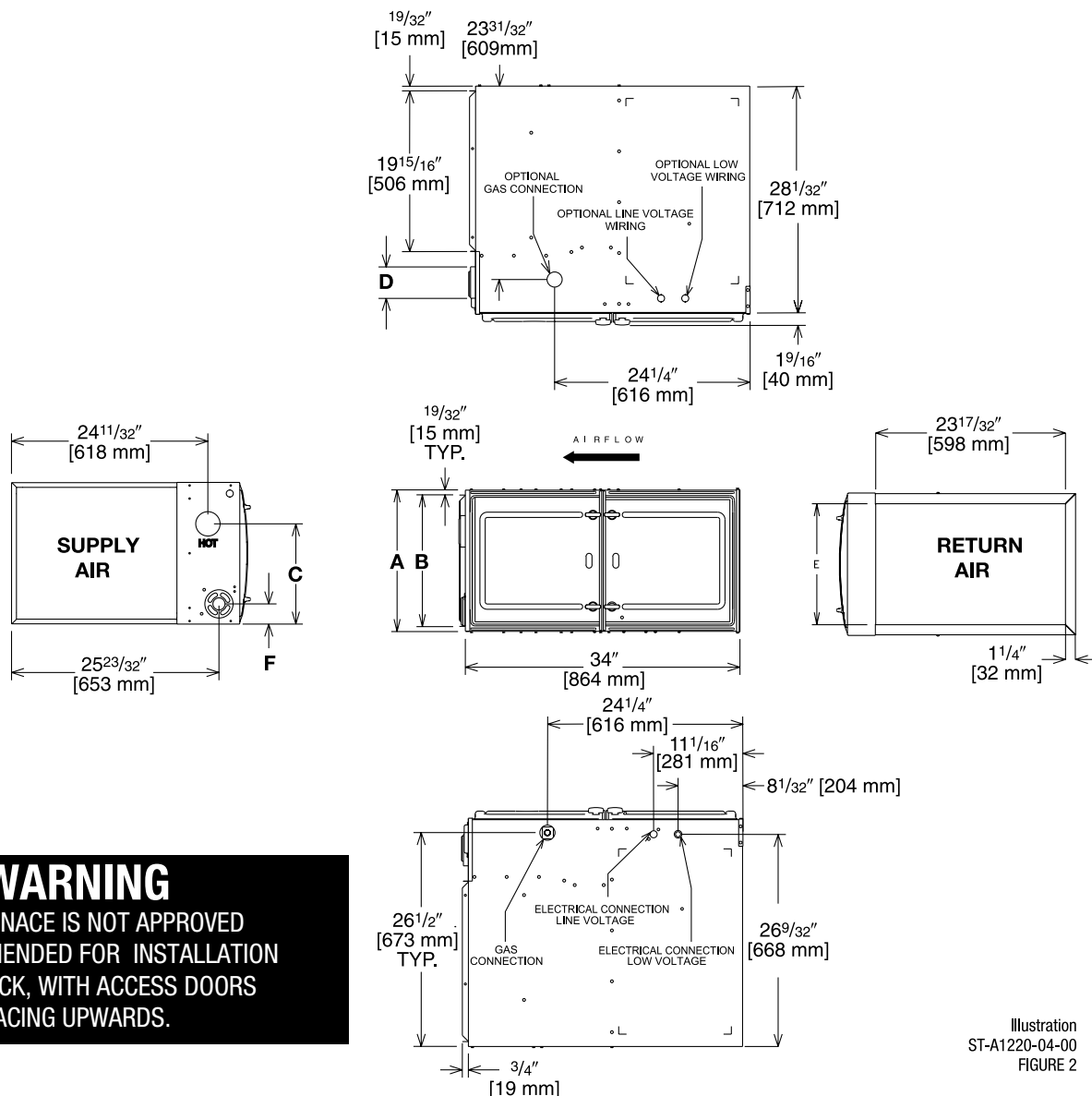

WARNING
THIS FURNACE IS NOT APPROVED
OR RECOMMENDED FOR INSTALLATION
ON ITS BACK, WITH ACCESS DOORS
FACING UPWARDS.

Illustration
ST-A1220-04-00
FIGURE 2

Dimensional Data: Horizontal Model

MODEL R801T-	A	B	C	D	E	F	MINIMUM CLEARANCE (IN.) [mm]					SHIP WGTS. (LBS.) [kg]	
							SUPPLY AIR SIDE	RETURN AIR SIDE	BACK	TOP	FRONT		VENT
050/070	17 1/2 [445]	16 11/32 [415]	12 3/8 [314]	①	15 [381]	2 1/2 [64]	3 [76] ②	3 [76] ②	0	1 [25]	3 [76]	6 [152] ③	125 [57]
100	21 [533]	19 27/32 [504]	14 1/8 [359]	①	18 1/2 [470]	2 1/2 [64]	0	0	0	1 [25]	3 [76]	6 [152] ③	140 [64]

NOTES: ① May require a 3" [76 mm] to 4" [102 mm] or 3" [76 mm] to 5" [127 mm] adapter.

② May be 0" [0 mm] with type B vent.

③ May be 1" [25 mm] with type B vent.

Furnaces must be vented in accordance with the National Fuel Gas Code, ANSI Z223.1 and in accordance with local codes.

[] Designates Metric Conversions

Blower Performance Data

AIR FLOW PERFORMANCE - R801T SERIES MODELS												
MODEL INPUT	MOTOR H.P. [W] BLOWER SIZE IN [mm]	AIRFLOW CONTROL SETTINGS	MOTOR SPEED	CFM AIR DELIVERY EXTERNAL STATIC PRESSURE " OF W.C. [kPa]								
				0.1 [.02]	0.2 [.05]	0.3 [.07]	0.4 [.10]	0.5 [.12]	0.6 [.15]	0.7 [.17]	0.8 [.20]	0.9 [.22]
				17" CAB 3 Ton/50K	1/2 [373] 11 X 6 [279 X 152]	Factory Heat	Low	783	709	664	610	559
Factory Fan	Med-Low	987	942			902	866	833	793	755	713	675
Option Cool 2.5 Tons	Med	1126	1096			1064	1030	996	966	934	897	869
Factory Cool 3 Tons	Med-High	1305	1276			1252	1221	1195	1164	1139	1110	1084
Option Cool 3.5 Tons	High	1410	1377			1353	1327	1310	1284	1259	1233	1210
17" CAB 4 Ton/50K	3/4 [559] 11 X 6 [279 X 152]	Factory Fan	Low	779	708	659	612	557	511	470	438	395
		Option Cool 2 Tons	Med-Low	982	949	906	869	832	794	756	716	680
		Factory Heat	Med	1116	1086	1057	1020	992	961	930	896	870
		Option Cool 3 Tons	Med-High	1301	1274	1244	1216	1191	1165	1137	1111	1086
		Factory Cool 4 Tons	High	1583	1555	1527	1504	1481	1453	1431	1405	1386
17" CAB 3 Ton/70K	1/2 [373] 11 X 7 [279 X 177]	Factory Fan	Low	892	834	783	729	674	623	568	518	472
		Option Cool 2 Tons	Med-Low	1047	1004	958	909	860	814	764	721	682
		Factory Heat	Med	1141	1097	1059	1016	971	929	884	844	803
		Factory Cool 3 Tons	Med-High	1357	1316	1283	1243	1204	1169	1135	1091	1055
		Option Cool 3.5 Tons	High	1493	1462	1424	1390	1358	1327	1291	1262	1229
17" CAB 4 Ton/70K	3/4 [559] 11 X 7 [279 X 178]	Factory Fan	Low	889	841	784	730	671	620	510	510	460
		Option Cool 2 Tons	Med-Low	1046	1002	949	904	852	811	762	723	679
		Factory Heat	Med	1141	1097	1059	1016	971	929	884	844	803
		Option Cool 3 Tons	Med-High	1363	1327	1288	1255	1210	1175	1135	1097	1068
		Factory Cool 4 Tons	High	1785	1745	1714	1688	1661	1627	1602	1569	1551
21" CAB 5 Ton/100K	3/4 [559] 11 X 10 [279 X 254]	Factory Fan	Low	1098	1064	1017	975	922	861	806	767	698
		Option Cool 3.5 Tons	Med-Low	1373	1331	1297	1267	1228	1182	1131	1076	1023
		Factory Heat	Med	1499	1474	1443	1419	1389	1353	1310	1272	1226
		Option Cool 4 Tons	Med-High	1668	1644	1612	1595	1570	1536	1509	1466	1427
		Factory Cool 5 Tons	High	1870	1849	1815	1785	1771	1736	1714	1681	1607
21" CAB 5 Ton/100K	1[746] 11 X 10 [279 X 254]	Factory Fan	Low	838	773	700	623	561	485	408	331	267
		Option Cool 3.5 Tons	Med-Low	1451	1414	1380	1344	1311	1277	1230	1181	1132
		Factory Heat	Med	1529	1488	1461	1421	1393	1355	1314	1279	1232
		Option Cool 4 Tons	Med-High	1602	1569	1529	1501	1470	1439	1404	1367	1318
		Factory Cool 5 Tons	High	2124	2098	2074	2047	2024	1996	1979	1943	1905

[] Designates Metric Conversions

**BOTTOM RETURN FILTER RACK FOR
UPFLOW APPLICATION: RXGF-CB**

SIDE RETURN FILTER RACK: RXGF-CD

FILTER RACK FILTER SIZES* INCHES [mm]		
MODEL	RXGF-CB (UPFLOW/ HORIZONTAL)	RXGF-CD (UPFLOW) SIDE RETURN
R801TA050/ R801TA070	12 ¹ / ₄ x 25 [311 x 635]	15 ³ / ₄ x 25 [400 x 635]
R801TA100	19 ¹ / ₄ x 25 [489 x 635]	15 ³ / ₄ x 25 [400 x 635]

4" FLUE ADAPTER: RXGW-C01

Indoor Coil Casings

MODEL NUMBER
RXBC-D17AI
RXBC-D21AI
RXBC-D21BI

WARNING: IMPORTANT NOTICE

A SOLID METAL BASE PLATE (SEE TABLE) MUST BE IN PLACE WHEN THE FURNACE IS INSTALLED WITH SIDE AIR RETURN DUCTS. FAILURE TO INSTALL A BASE PLATE COULD CAUSE PRODUCTS OF COMBUSTION TO BE CIRCULATED INTO THE LIVING SPACE AND CREATE POTENTIALLY HAZARDOUS CONDITIONS.

FURNACE WIDTH IN. [mm]	SOLID BOTTOM KIT NO.	BASE PLATE NO.	BASE PLATE SIZE IN. [mm]
17 ¹ / ₂ [445]	RXGB-D17	AE-61874-02	15 ¹ / ₈ x 23 ⁹ / ₁₆ [384 x 598]
21 [533]	RXGB-D21	AE-61874-03	18 ⁵ / ₈ x 23 ⁹ / ₁₆ [473 x 598]

For High Altitudes:

HIGH ALTITUDE OPTION CODE: U.S.

None required for high altitudes.

HIGH ALTITUDE CONVERSION KITS: U.S.

None required for high altitudes.

80+ HIGH ALTITUDE INSTRUCTIONS

CAUTION: Always follow National Fuel Gas Code (NFGC) guidelines when converting for high altitudes.

High altitude option codes are not required for these models. However, the burner orifice size needs to be recalculated and verified at elevations above 2000 ft. See Installation Instructions for more information.

[] Designates Metric Conversions



GENERAL TERMS OF LIMITED WARRANTY*

Ruud will furnish a replacement for any part of this product which fails in normal use and service within the applicable period stated, in accordance with the terms of the limited warranty.

***For complete details of the Limited and Conditional Warranties, including applicable terms and conditions, contact your local contractor or the Manufacturer for a copy of the product warranty certificate.**

Conditional Parts
(Registration Required) Ten (10) Years
Heat Exchanger Twenty (20) Years

Before proceeding with installation, refer to installation instructions packaged with each model, as well as complying with all Federal, State, Provincial, and Local codes, regulations, and practices.

© 2026 Rheem Manufacturing Company. Trademarks are property of their respective owners.

In keeping with its policy of continuous progress and product improvement, manufacturer reserves the right to make changes without notice.

5600 Old Greenwood Road
Fort Smith, Arkansas 72908 • Ruud.com

125 Edgeware Road, Unit 1
Brampton, Ontario • L6Y 0P5 • Ruud-canada.ca