



PROJECT NAME \_\_\_\_\_  
 LOCATION \_\_\_\_\_  
 ARCHITECT \_\_\_\_\_  
 ENGINEER \_\_\_\_\_  
 CONTRACTOR \_\_\_\_\_  
 SUBMITTED BY \_\_\_\_\_ DATE \_\_\_\_\_

**UNIT SUMMARY**

Quantity						
Unit Designation						
Model No.						
Total Cooling						
Sensible Cooling						
Air Ent. Evaporator						
Air Lvg. Evaporator						
Heating Input						
Heating Output						
CFM/ESP						
EER/SEER						
Electrical						
Minimum Ampacity						
Min.-Max. Breaker						
Net Unit Weight						
Accessory						
Catalog Form Number						

**ACCESSORIES:**

**NOTES:**

# Endeavor® Line (-)802V Upflow/Horizontal Gas Furnaces

## Heating Stages: Two Stage

### Input Rates: 50-100 kBTU [14.7-29.3 kW]

JOB NAME \_\_\_\_\_ LOCATION \_\_\_\_\_

CONTRACTOR \_\_\_\_\_ ORDER NO. \_\_\_\_\_

ENGINEER \_\_\_\_\_ UNIT MODEL NO. \_\_\_\_\_

SUBMITTED FOR  APPROVAL  RECORD COIL MODEL NO. \_\_\_\_\_

DATE \_\_\_\_\_ AIR HANDLER MODEL NO. \_\_\_\_\_

#### UNIT DATA

##### HEATING PERFORMANCE

TOTAL CAPACITY INPUT\* ..... \_\_\_\_\_ MBH [kW]

TOTAL CAPACITY OUTPUT\* ..... \_\_\_\_\_ MBH [kW]

DESIGN TEMP. RISE..... \_\_\_\_\_ °F [°C] DB

AFUE ..... \_\_\_\_\_ %

CALIFORNIA SEASONAL EFFICIENCY ..... \_\_\_\_\_ %

(\*uses blower motor heat)

##### SUPPLY AIR BLOWER PERFORMANCE

TOTAL AIR SUPPLY..... \_\_\_\_\_ CFM [L/s]

TOTAL RESISTANCE EXTERNAL TO UNIT..... \_\_\_\_\_ IWG

BLOWER SPEED..... \_\_\_\_\_ RPM

POWER OUTPUT REQUIREMENT ..... \_\_\_\_\_ BHP

MOTOR RATING ..... \_\_\_\_\_ HP [W]

POWER INPUT REQUIREMENT ..... \_\_\_\_\_ kW

##### ELECTRICAL DATA

POWER SUPPLY..... \_\_\_\_\_ Hz

TOTAL UNIT AMPACITY..... \_\_\_\_\_ AMPS

MINIMUM WIRE SIZE..... \_\_\_\_\_ AWG

MAXIMUM OVERCURRENT DEVICE FUSES/HACR BREAKER ..... \_\_\_\_\_ AMPS



#### FEATURES

- **PlusOne® Diagnostics:** With the Contractor & EcoNet® Apps, built-in EcoNet® & Bluetooth®<sup>1</sup> technology makes monitoring, troubleshooting and repairing the product easier than ever before
- **Dip Switch Free Installation Commissioning via Bluetooth® Technology:** Seamless final install step without DIP switch configuration using the Contractor App
- **PlusOne® Ignition System:** Proven Direct Spark Ignition (DSI) for reliability and longevity
- **Two-Stage Heating:** Furnace operation mainly stays at low capacity around 60-65%, but will switch to high capacity to deliver stable heat distribution
- **Constant CFM Motor:** Truly variable speed technology allows for ultimate humidity control, quieter sound levels and year-round energy savings
- **Quieter Operation<sup>2</sup>:** A fully insulated blower cabinet, solid bottom and truly variable speed airflow technology makes this furnace one of the quieter options available
- **EcoNet® Enabled Furnace:** The latest in sensor technology and the EcoNet® monitoring system provides a new level of protection, control and energy savings
- **Allows on-the-go control** and receipt of system alerts by the homeowner via the EcoNet® Smart Thermostat and EcoNet® App<sup>3</sup>

#### FIELD INSTALLED ACCESSORIES

- External Bottom Filter Rack RXGF-CB.....
- External Side Filter Rack RXGF-CD.....
- Indoor Coil Casing RXBC-D14A1.....
- Indoor Coil Casing RXBC-D17A1.....
- Indoor Coil Casing RXBC-D21A1.....
- Indoor Coil Casing RXBC-D21B1.....
- Indoor Coil Casing RXBC-D24A1.....
- Solid Bottom Kit RXGB-D14.....
- Solid Bottom Kit RXGB-D17.....
- Solid Bottom Kit RXGB-D21.....
- Solid Bottom Kit RXGB-D24.....
- 4" Flue Adapter RXGW-C01.....



<sup>1</sup>The Bluetooth® word mark and logos are registered trademarks owned by Bluetooth SIG, Inc. and any use of such marks by Rheem® is under license. Other trademarks and trade names are those of their respective owners.

<sup>2</sup>Based on manufacturer's furnace offering, and the product's heating stages, motor type and cabinet insulation. Sound levels are also dependent on furnace location and installation.

<sup>3</sup>Wifi broadband internet connection required. Download the EcoNet® App from the App Store® or Google Play® to set up your EcoNet® Smart Thermostat. Receipt of notifications depend on home WIFI set up. Amazon, Alexa and all related logos are trademarks of Amazon.com, Inc. or its affiliates.

(-)802V UH

## Horizontal Application

# WARNING

THIS FURNACE IS NOT APPROVED OR RECOMMENDED FOR INSTALLATION ON ITS BACK, WITH ACCESS DOORS FACING UPWARDS.

## Upflow Application

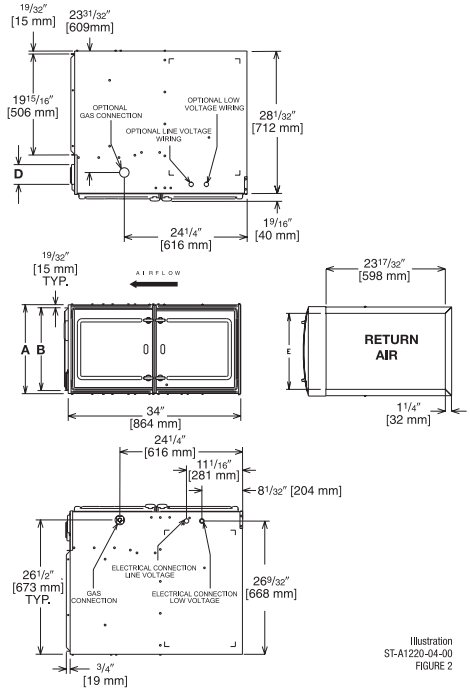

Illustration ST-A1220-04-00 FIGURE 2

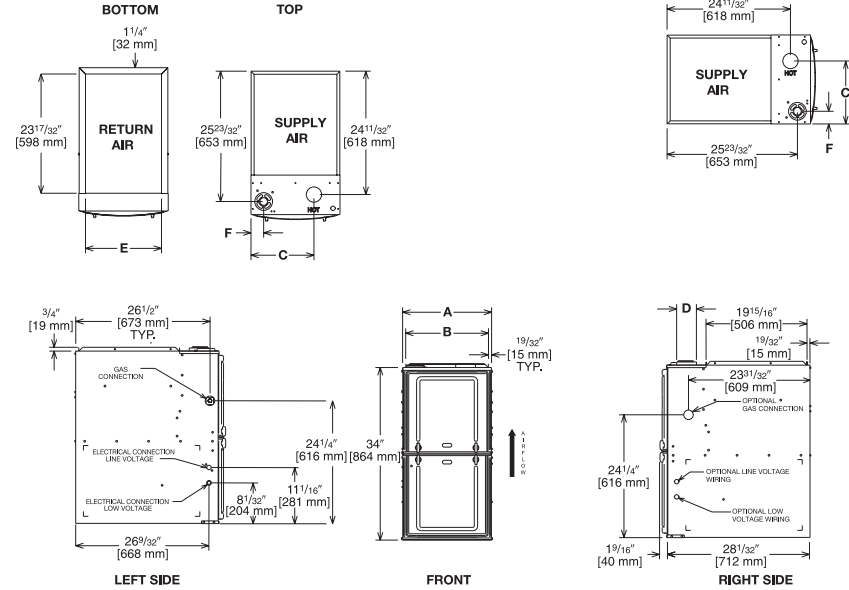

Illustration ST-A1220-04-00 FIGURE 1

## Dimensional Data: Upflow Model

MODEL (-)802V UH	A	B	C	D	E	F	MINIMUM CLEARANCE (IN.) [mm]					
							SUPPLY AIR SIDE	RETURN AIR SIDE	BACK	TOP	FRONT	VENT
050314	14 [356]	12 <sup>27</sup> / <sub>32</sub> [326]	10 <sup>5</sup> / <sub>8</sub> [270]	Ⓚ	11 <sup>1</sup> / <sub>2</sub> [292]	17 <sup>7</sup> / <sub>8</sub> [48]	4 [102] ②	4 [102] ②	0	1 [25]	3 [76]	6 [152] ③
050417/75417	17 <sup>1</sup> / <sub>2</sub> [445]	16 <sup>1</sup> / <sub>32</sub> [415]	12 <sup>3</sup> / <sub>8</sub> [314]	Ⓚ	15 [381]	2 <sup>1</sup> / <sub>2</sub> [64]	3 [76] ②	3 [76] ②	0	1 [25]	3 [76]	6 [152] ③
075521/100	21 [533]	19 <sup>27</sup> / <sub>32</sub> [504]	14 <sup>1</sup> / <sub>8</sub> [359]	Ⓚ	18 <sup>1</sup> / <sub>2</sub> [470]	2 <sup>1</sup> / <sub>2</sub> [64]	0	0	0	1 [25]	3 [76]	6 [152] ③
125	24 <sup>1</sup> / <sub>2</sub> [622]	23 <sup>11</sup> / <sub>32</sub> [592]	15 <sup>7</sup> / <sub>8</sub> [403]	Ⓚ	22 [559]	2 <sup>1</sup> / <sub>2</sub> [64]	0	0	0	1 [25]	3 [76]	6 [152] ③

## Dimensional Data: Horizontal Model

MODEL (-)802V UH	A	B	C	D	E	F	MINIMUM CLEARANCE (IN.) [mm]					
							SUPPLY AIR SIDE	RETURN AIR SIDE	BACK	TOP	FRONT	VENT
050314	14 [356]	12 <sup>27</sup> / <sub>32</sub> [326]	10 <sup>5</sup> / <sub>8</sub> [270]	Ⓚ	11 <sup>1</sup> / <sub>2</sub> [292]	17 <sup>7</sup> / <sub>8</sub> [48]	4 [102] ②	4 [102] ②	0	1 [25]	3 [76]	6 [152] ③
050417/75417	17 <sup>1</sup> / <sub>2</sub> [445]	16 <sup>1</sup> / <sub>32</sub> [415]	12 <sup>3</sup> / <sub>8</sub> [314]	Ⓚ	15 [381]	2 <sup>1</sup> / <sub>2</sub> [64]	3 [76] ②	3 [76] ②	0	1 [25]	3 [76]	6 [152] ③
075521/100	21 [533]	19 <sup>27</sup> / <sub>32</sub> [504]	14 <sup>1</sup> / <sub>8</sub> [359]	Ⓚ	18 <sup>1</sup> / <sub>2</sub> [470]	2 <sup>1</sup> / <sub>2</sub> [64]	0	0	0	1 [25]	3 [76]	6 [152] ③
125	24 <sup>1</sup> / <sub>2</sub> [622]	23 <sup>11</sup> / <sub>32</sub> [592]	15 <sup>7</sup> / <sub>8</sub> [403]	Ⓚ	22 [559]	2 <sup>1</sup> / <sub>2</sub> [64]	0	0	0	1 [25]	3 [76]	6 [152] ③

NOTES: ① May require a 3" [76 mm] to 4" [102 mm] or 3" [76 mm] to 5" [127 mm] adapter.

[ ] Designates Metric Conversions

② May be 0" [0 mm] with type B vent.

③ May be 1" [25 mm] with type B vent.

Furnaces must be vented in accordance with the National Fuel Gas Code, ANSI Z223.1 and in accordance with local codes.

Before proceeding with installation, refer to installation instructions packaged with each model, as well as complying with all Federal, State, Provincial, and Local codes, regulations, and practices.

5600 Old Greenwood Road  
Fort Smith, Arkansas 72908

© 2023 Rheem Manufacturing Company. Rheem, Ruud and Friedrich trademarks owned by Rheem Manufacturing Company.

"In keeping with its policy of continuous progress and product improvement, Rheem reserves the right to make changes without notice."