



MODEL: RGEC Packaged Gas Electric Units



FORM NO. RRR-880

Renaissance™ Line Packaged Gas Electric Units



RGEC

- Cooling Efficiencies up to:
3-5 Tons: 10.6 EER2 / 13.4 SEER2
6 Tons: 11.0 EER / 14.6 IEER
- Nominal Sizes: 3, 4, 5 & 6 Tons
[10.6, 14.0, 17.6 & 21.1 kW]
- Cooling Capacities: 34.2 kBTU - 72.0 kBTU
- Refrigerant Type: R-454B
- ASHRAE 90.1 2022 Compliant Models



TABLE OF CONTENTS

Unit Features & Benefits	3-10
Model Number Identification	11
Options	12
Selection Procedures	13
General Data.....	14-17
General Data Notes	18
Weighted Sound Power	19
Heating Performance Data.....	20-21
Cooling Performance.....	21-25
Gross Systems Performance Data	25-30
Airflow Performance Data	31-34
Electrical Data.....	35-44
A2L Refrigerant Installation Safety Data	45
Dimensional Data	46-48
Field-Installed Accessories.....	49-74
Guide Specifications	75-80
Limited Warranty	82

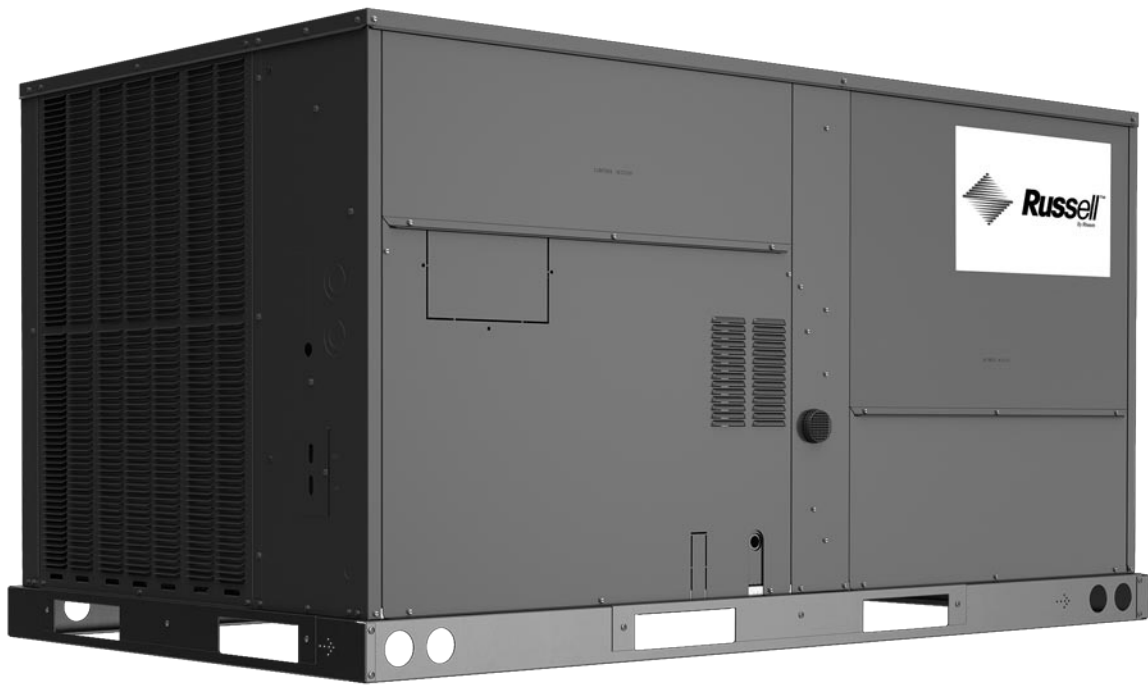

RGEC STANDARD FEATURES INCLUDE:

- Factory charged with R-454B refrigerant
- Wired and run tested
- Scroll compressors with internal line break overload and high pressure protection
- Convertible airflow – vertical down flow or horizontal side flow
- Forkable base rails for easy handling and lifting
- Cooling operation up to 125°F ambient
- Two-stage gas heat input with direct spark ignition system, solid state furnace controls, and optimized induced draft combustion
- MicroChannel evaporator and condenser coil
- ServiceSmart package includes:
Qwik-Change Flex-Fit Rack
Qwik-Slide Blower Assembly
Qwik-Clean Drain Pan
- Overflow condensate sensor
- Diagnostics with Dual 7-Segment LED Display to meet code compliance
- One-piece top cover and base pan with drawn supply and return opening
- Two-piece control door
- ¼ turn fasteners on filter access door
- Color-coded and labeled wiring
- External lockable gauge ports
- TXV refrigerant metering system
- Solid-core liquid line filter drier
- High pressure and low pressure/loss of charge protection with built-in Smart Logic
- Insulation encapsulated throughout entire unit
- 3-5 ton YB models include one single-stage compressor
- MERV 8 & MERV 13 filters are available as a field-installed accessory
- Standard Modbus interface



For 2025, the Environmental Protection Agency (EPA) has set a global warming potential (GWP) limit of 700 for refrigerant used in most heating and cooling systems. This new requirement will result in a 78%* lower GWP than previous-generation refrigerants—with only minimal changes to system installation. For us, this is another step toward our ongoing sustainability goal of reducing greenhouse gas emissions, while still delivering an exceptional level of energy efficient, dependable comfort.

*When comparing the GWP of R-454B to R-410A refrigerant.

FACTORY-INSTALLED OPTIONS:

- Louvered panels
- Hinged access doors
- Stainless steel heat exchanger (20 year warranty)
- Low ambient/freeze stat
- Non-powered convenience outlet
- Unfused disconnect
- Circuit breaker

- Economizer (Title 24 and ASHRAE 90.1 2022 compliant)
- Supply and return smoke detector
- Return smoke detector
- ElectroFin® E-Coat for Microchannel Condenser Coil Coating
- ClearControl™ Direct Digital Control (DDC)
- Comfort Alert® Phase-monitor Protection
- Vertical Economizer

FIELD-INSTALLED ACCESSORIES:

Accessory	Model Number	Factory Installation Available?
Comfort Alert (1 Phase) DDC	RXXR-AZ03	Yes
Comfort Alert (1 Phase) Non-DDC	RXXR-AZ04	Yes
Comfort Alert (3 Phase) DDC	RXXR-AZ01	Yes
Comfort Alert (3 Phase) Non-DDC	RXXR-AZ02	Yes
Communication Card, BACnet®	RXXR-AY01	No
Communication Card, LonWorks®	RXXR-AY02	No
Concentric Adapter 3-4 Ton Drop	RXMC-DC01	No
Concentric Adapter 5-6 Ton Drop	RXMC-DC02	No
Concentric Diffuser 3-4 Ton Drop	RXRN-AED1800	No
Concentric Diffuser 5-6 Ton Drop	RXRN-AED2000	No
Concentric Diffuser 3-4 Ton Flush	RXRN-AEF1800	No
Concentric Diffuser 5-6 Ton Flush	RXRN-AEF2000	No
Convenience Outlet, Nonpowered	RXXR-BN01	Yes
Dual Enthalpy Kit (for Honeywell® Jade™)	RXXR-BV01	No
Dual Enthalpy Kit DDC (for Honeywell® DDC)	RXXR-BV02	No
Dual Enthalpy, Temperature and Humidity Sensor (for Ruskin Basic Controller)	PD955878	No
Dual Enthalpy, Temperature and Humidity Sensor (for Siemens®)	PD555460	No
Economizer Universal DDC Interface Kit	RXXR-DDC01	Yes
Economizer with No Controls (Downflow/Vertical) <i>MicroMetl Economizer, No Controls, Belimo Actuator</i>	RXRD-31MCDAM3	No
Economizer w/Single Enthalpy (Downflow/Vertical) <i>MicroMetl Economizer with Honeywell® Jade™ Controls</i>	RXRD-01MCDAM3	Yes
Economizer w/Single Enthalpy (Downflow/Vertical) <i>Ruskin Rooftop Systems® with RRS Basic Controller</i>	RXRD-41MCDAM3	No
Economizer w/Single Enthalpy (Downflow/Vertical) <i>MicroMetl Economizer with Siemens Controls</i>	RXRD-11MCDAM3	No
Economizer-w/Single Enthalpy (Downflow/Vertical) DDC <i>MicroMetl Economizer with Honeywell DDC Controls</i>	RXRD-01MCDAM3	Yes
Economizer w/Single Enthalpy (Horizontal) <i>MicroMetl Economizer with Honeywell Jade Controls</i>	RXRD-01MCHAM3	No
Economizer w/Single Enthalpy (Horizontal) <i>MicroMetl Economizer with Siemens Controls</i>	RXRD-11MCHAM3	No

*10kW options not available on 6 Ton models

Accessory	Model Number	Factory Installation Available?
Economizer w/Single Enthalpy (Horizontal) <i>Ruskin Rooftop Systems with RRS Basic Controller</i>	RXRD-41MCHAM3	No
Economizer w/Single Enthalpy (Horizontal) DDC <i>MicroMetl Economizer with Honeywell DDC Controls</i>	RXRD-01MCHBM3	No
Flue Diverter (RGEC 75K, 100K & 120K)	RXXR-DEG03	No
Freeze Stat Kit	RXXR-AM05	Yes
Fresh Air Damper, Manual	RXRF-ACA1	No
Fresh Air Damper, Motorized	RXRF-ACB1	No
Low-Ambient Control Kit	RXRZ-A04	Yes
LP Kit (RGEC 75K, 120K)	RXGJ-FP40	No
LP Kit (RGEC 100K)	RXGJ-FP41	No
MERV 8 Filter	RXMF-M08A21616	No
MERV 13 Filter	RXMF-M13A21616	No
Outdoor Coil Louver Kit	RXXR-ADD04C	Yes
Power Exhaust (230V) Horizontal <i>MicroMetl</i>	RXXR-CCF03C	No
Power Exhaust (230V) Horizontal <i>Ruskin Rooftop Systems</i>	RXXR-RCF03C	No
Power Exhaust (230V) Vertical <i>MicroMetl</i>	RXXR-CCF02C	No
Power Exhaust (230V) Vertical <i>Ruskin Rooftop Systems®</i>	RXXR-RCF02C	No
Power Exhaust (460V) Horizontal <i>MicroMetl</i>	RXXR-CCF03D	No
Power Exhaust (460V) Horizontal <i>Ruskin Rooftop Systems®</i>	RXXR-RCF03D	No
Power Exhaust (460V) Vertical <i>MicroMetl</i>	RXXR-CCF02D	No
Power Exhaust (460V) Vertical <i>Ruskin Rooftop Systems®</i>	RXXR-RCF02D	No
Roofcurb, 14"	RXKG-DCC14	No
Roofcurb, 24"	RXKG-DCC24	No
Roofcurb Adapter	RXXR-DCCAE	No
Sensor, Carbon Dioxide (Wall Mount)	RXXR-AR02	No
Sensor, Room Humidity	RHC-ZNS4	No
Sensor, Room Temperature and Relative Humidity	RHC-ZNS5	No
Smoke Detector, Return (Field kit)	RXXR-BS01	No
Smoke Detector, Return/ Supply (Field kit)	RXXR-BS02	No
Unfused Service Disconnect	RXXR-BP01	Yes

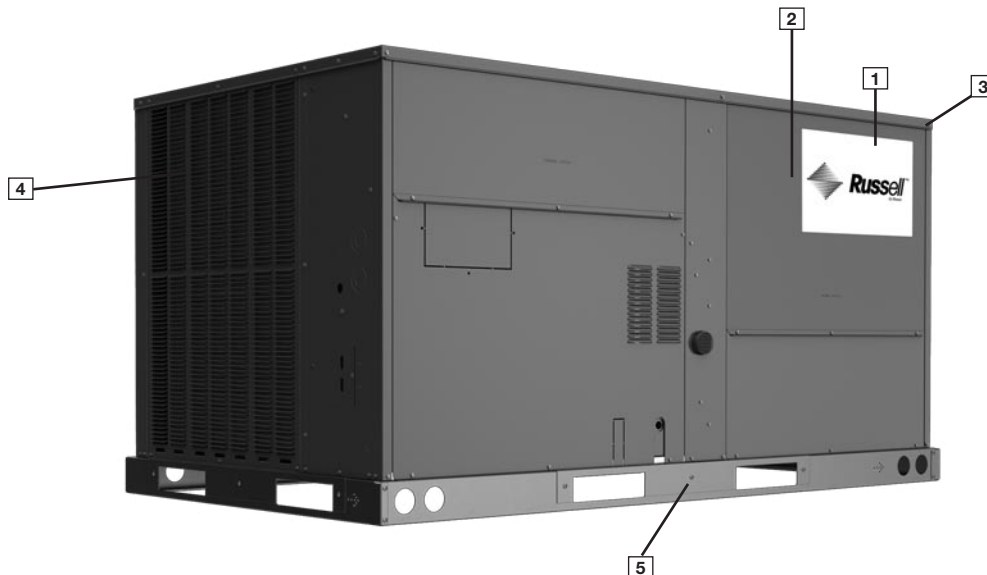

Cabinet and Foundation

Outwardly, the large Russell® By Rheem label (1) identifies the brand to the customer. The sheet-metal cabinet (2) uses 18-gauge material for structural components with an underlying coat of G90. To ensure the leak-proof integrity of these units, the design utilizes a one-piece top with a 1/8" drip lip (3) as well as gasket-protected panels and screws. The Russell® By Rheem hail guard (optional) (4) sets the standard for coil protection in the industry. Electro deposition, baked-on enamel that is tested to withstand a rigorous 1000-hour salt spray test, per ASTM B117.

Anything built to last must start with the right foundation. Following that model, the foundation is comprised of 14-gauge, commercial-grade, full perimeter base rails (5) that integrate fork slots and rigging holes to save set-up time on the job site.

Easy Installation

The Renaissance line features a footprint that simplifies the replacement process by eliminating the need for a new curb adapter and being able to match inlet, outlet and electrical connections of the most common/industry-standard configurations.

Base Pan

The base pan is stamped to form a 7/8" flange around the supply and return cover, which eliminates the worry of water entering the conditioned space (6). All insulation is secured with both adhesive and mechanical fasteners, and all edges are hidden.



Drain Pan

The Qwik-Clean Drain Pan (7) is made from a composite material that resists the growth of harmful bacteria. With both side and center drain options, the drain pan slides out completely for easy cleaning. It also features a standard overflow switch.



Test Standards

During development, each unit was tested to U.L. 60335-2-40, AHRI 210/240 (3-5 ton) or AHRI 340/360 (6 ton), as well as other Russell® By Rheem-required reliability tests. Russell® By Rheem adheres to stringent ISO 9001 quality procedures, and each unit bears the U.L. and AHRI certification labels located on the unit nameplate. Contractors can be assured that when a Russell® By Rheem packaged unit arrives at the job, it is ready to go with a factory charge and quality checks.

Easy Access

All major compartments are easily accessible from the front of the unit: the electrical compartment, blower compartment, heating section, and outdoor section. Each compartment has mechanical fasteners. Panels are permanently embossed with the compartment name (e.g. control/filter access, blower access, and electric heat access). The filter compartment is accessed through a large, mechanically fastened panel. Information is readily available on the outside of the panel, with a nameplate that contains the model and serial numbers, electrical data, and other important unit information. Hinged access is available as an option for the electrical, blower, and filter compartments.

Charging Charts, Wiring Diagrams, & Labels

The unit charging chart is located on the outside of the compressor access panel. Electrical wiring diagrams are found on the control box cover, which allows contractors to move them to more readable locations. The model and serial numbers are located on the right of the control box. Having this information on the inside means easier model identification for the life of the product. The production line quality test assurance label is also placed in this location (8).

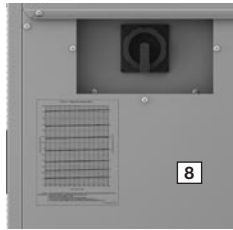

Filter Rack

Located within the filter compartment, the Qwik-Change Flex-Fit Rack (9) allows easy changeover between 2" and 4" standard size and readily available filters.



Blower Assembly

Removing three screws provides full access to the blower compartment. Inside, the Qwik-Slide Blower Assembly (10) is incredibly easy to access and remove. This makes servicing internal components such as blower motor, TXV, and microchannel coil much easier. The entire assembly slides out by removing the 3/8" screws from the blower retention bracket.

Where the demands for the job require high static, Russell® By Rheem offers drives that deliver nominal airflow up to 1.5" of static. By referring to the airflow performance tables listed in the installation instructions, proper static pressure and CFM requirements can be dialed in. The scroll housing (12) and blower scroll provide quiet and efficient airflow.

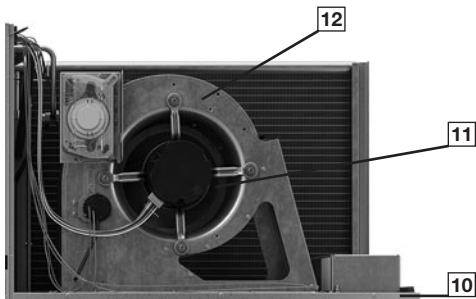

High and Low Pressure Switches & Freeze Stat

High pressure (13) and low pressure (14) switches are standard. They are located in the outdoor section along with the low-ambient control (15). The optional Freeze Stat (16) (standard on models with ClearControl), is clipped onto the suction line in the blower compartment. The low ambient control allows the compressor to operate down to 0 degrees ambient temperature by cycling the outdoor fans on high pressure. The high-pressure switch shuts off the compressors if pressures exceeding 610 PSIG are detected. The low-pressure switch shuts off the compressors if low pressure is detected due to loss of charge. Built-in Smart Logic reduces nuisance calls by only shutting off compressors after the third detection. The freeze stat protects the compressor if the evaporator coil gets too cold (below freezing) due to low airflow.

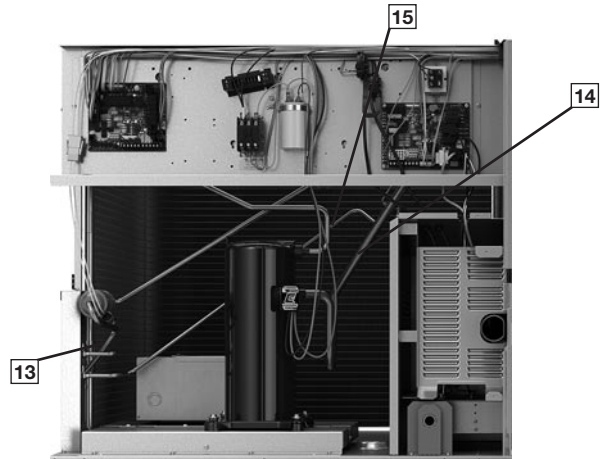

MicroChannel Evaporator & TXV

The Microchannel Evaporator (17) is accessible through the blower compartment, and through the filter rack, to simplify cleaning. The evaporator uses microchannel technology for maximum heat transfer, light weight, fewer manually brazed connections and reduced refrigerant charge. The TXV metering device maintains superheat over a wide range of varying temperatures optimizing unit performance for all conditions.

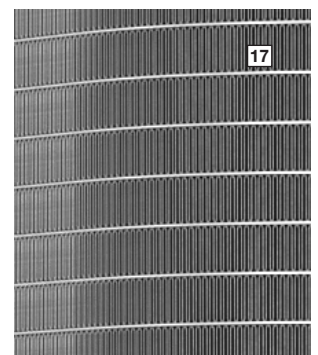

Control Box

Inside the control box (18), each electrical component is clearly labeled; that label matches the component to the wire diagram for ease of trouble shooting. All wiring is numbered on each end of the termination and is color-coded to match the wiring diagram. The integrated furnace control, incorporates the Diagnostics: Dual 7-Segment LED Display (19) with easy-to-understand fault codes. The control transformer has a low voltage circuit breaker that trips if an electrical short occurs.

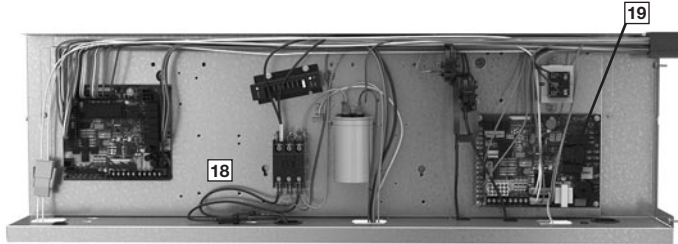

ClearControl DDC System

The optional ClearControl Direct Digital Control (DDC) system consisting of a rooftop unit controller, temperature sensors, and pressure sensors, allows real-time monitoring and communication between rooftop units. The Rooftop Unit Controller (RTU-C) that is factory mounted and wired into the control panel. The RTU-C is a solid-state, microprocessor-based control board that provides flexible control and extensive diagnostics for all unit functions. The RTU-C, using proportional/integral control algorithms, performs specific unit functions that govern unit operation in response to zone conditions, system temperatures, system pressures, ambient conditions, and electrical inputs. The RTU-C features a 16 x 2 character LCD display and a five-button keypad for local configuration and direct diagnosis of the system (20). Features include a clogged filter switch (CFS), fan proving switch (FPS), return air temperature sensor (RAT), discharge air temperature sensor (DAT), and outdoor air temperature sensor (OAT). Freeze sensors (FS) are used in place of freeze stats to allow measurement of refrigerant suction line temperatures.

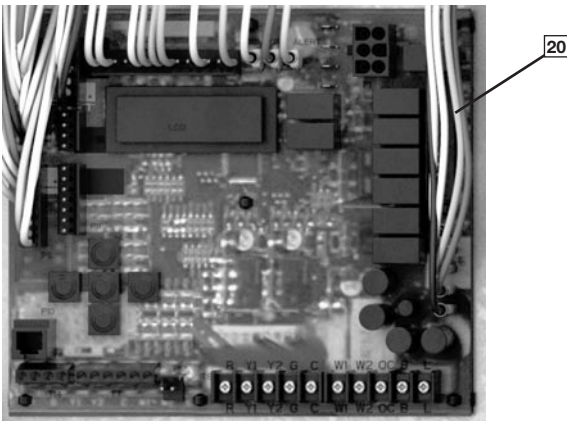

The RGEC Gas Electric with the RTU-C is specifically designed to be applied in four distinct applications:

- 1. BACnet Communication** — The RGEC is compatible with a third party building management system that supports the BACnet Application Specific Controller device profile, with the use of a field-installed BACnet Communication Module. The BACnet Communication Module plugs onto the unit RTU-C controller and allows communication between the RTU-C and the BACnet MSTP network. A zone sensor, a BACnet network zone sensor, a BACnet thermostat, or DDC controller may be used to send the zone temperature or thermostat demands to the RTU-C. The BACnet Communication Module is compatible with MSTP EIA-485 daisy chain networks communicating at 38.4 bps. It is compatible with twisted pair, shielded cables.
- 2. LonWorks Communication** — The RGEC is compatible with a third party building management system that supports the LonMark Space Comfort Controller (SCC) functional profile or LonMark Discharge Air Controller (DAC) functional profile. This is accomplished with a field-installed LonMark communication module. The LonMark Communication Module plugs onto the RTU-C controller and allows communication between the RTU-C and a LonWorks network. A zone sensor, a LonTalk network zone sensor, or a LonTalk thermostat or DDC controller may be used to send the zone temperature or thermostat demands to the RTU-C. The LonMark Communication Module utilizes an FTT-10A free topology transceiver communicating at 78.8 kbps. It is compatible with Echelon qualified, twisted pair cable, Belden 8471, or NEMA Level 4 cables. The module can communicate up to 1640 feet with no repeater. The LonWorks limit of 64 nodes per segment applies to this device.
- 3. 24V Thermostat Compatibility** — The RGEC is compatible with a programmable 24 volt thermostat. Connections are made via conventional thermostat screw terminals. Extensive unit status and diagnostics are displayed on the LCD screen of the RTU-C.
- 4. Zone Sensor Compatibility** — The RGEC is compatible with a zone sensor and a mechanical or solid state time clock connected to the RTU-C. Extensive unit status and diagnostics are displayed on the LCD screen of the RTU-C.

Comfort Alert

A factory or field-installed Comfort Alert (21) module is available for power phase-monitoring protection and additional compressor diagnostics. The alarms can be displayed on the RTU-C display, through the (BAS) network, or connected to the “L-Terminal” of a thermostat for notification.

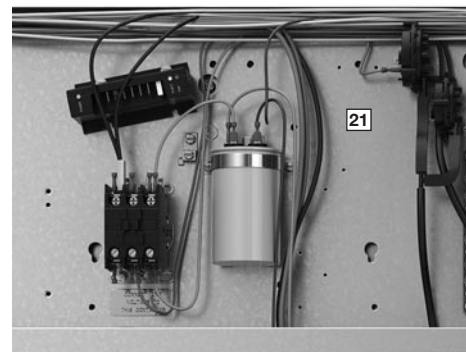

Convenience Outlet, Disconnect, & Circuit Breaker

The convenience outlet option comes non-powered from the factory (23), disconnect (24) and circuit breakers are available. Low and high voltage can enter from the side or through the base. Low-voltage connections are made through the low-voltage terminal strip. For ease of access, the U.L.-required low voltage barrier can be temporarily removed for low-voltage termination and then reinstalled. The high-voltage connection is terminated at the number 1 compressor contactor. The suggested mounting for the field-installed disconnect or circuit breaker is on the exterior side of the electrical control box.

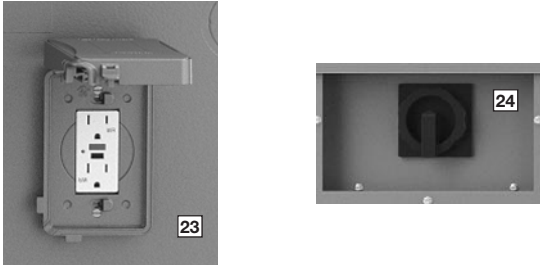

External Lockable Gauge Ports

To the right left of the compressor compartment are the externally mounted lockable gauge ports. They are permanently identified by embossed lettering that identifies the compressor circuit, high pressure connection, (25) and low pressure connection (26). Because the gauge ports are mounted externally, an accurate diagnostic of system operation can be performed without removing access panels. The plastic caps on the Shrader fitting ensure the gauge ports are leak proof, and the red cover on the caps indicates that this unit is charged with A2L refrigerant.

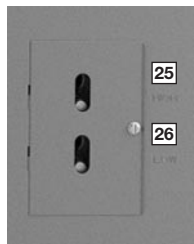

Furnace & Gas Heat Exchanger

The furnace compartment contains the latest technology on the market. Each furnace is equipped with a two-stage gas valve (27) to provide two stages of gas heat input. The first stage operates at 70% of the second stage (full fire), 81% steady state efficiency is maintained. Stainless steel heat exchangers can be factory installed for those applications that have high fresh-air requirements or in applications with corrosive environments. The direct spark igniter (28) ensures reliable ignition in the most adverse conditions. This is coupled with remote flame sensor so the flame is carried across the entire length of the burner assembly. Gas supply can be routed from the side or up through the base. Each furnace has the following safety devices to ensure consistent and reliable operation after ignition:

- Stainless steel heat exchanger warranty increases from 10 years to 20 years.
- Pressures switches to ensure adequate combustion airflow before ignition.
- Rollout switches to prevent obstruction or cracks in the heat exchanger.
- A limit device to protect the furnace from over-temperature problems.

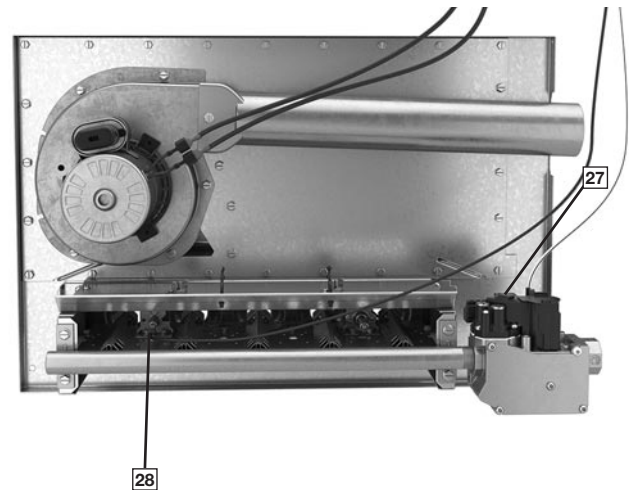

Compressor

The compressor compartment houses the heartbeat of the unit. The scroll compressor (30) is known for its long life and for reliable, quiet, and efficient operation. The suction and discharge lines are designed with shock loops (31) to absorb the strain and stress that the starting torque, steady state operation, and shut-down cycle impose on the refrigerant tubing. 3-5 ton YB units include one single-stage compressor, and 6 ton YB units include one two-stage compressor.

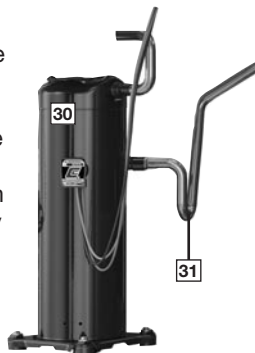

Condenser Fans

The condenser fan motor (32) can easily be accessed and maintained through the top of the unit. A down-mount fan provides corrosion protection and easy removal. The polarized plug connection allows the motor to be changed quickly and eliminates the need to snake wires through the unit.



MicroChannel Condenser Technology

The outdoor coil uses the latest microchannel technology (33) for the most effective method of heat transfer. The outdoor coil is protected by optional louvered panels, which allow unobstructed airflow while protecting the unit from both the environment and vandalism.

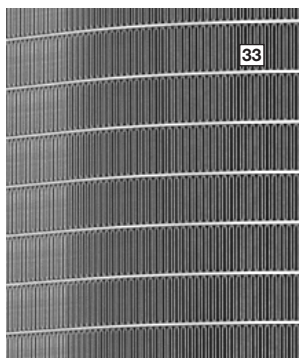

Coil Coating

Every unit offers the option of factory-applied ElectroFin® E-Coat condenser coating (34) that delivers superior corrosion resistance for outdoor coils to operate in the harshest of environments.



Economizer and Dampers

Each unit is designed for both down flow or horizontal applications (35) for job configuration flexibility. The return air compartment can also contain an economizer. Each unit is pre-wired for the economizer to allow quick, plug-in installation. Available as a factory-installed option, the economizer provides free cooling when outdoor conditions are suitable and also provides fresh air to meet local requirements.



It comes standard with single enthalpy controls, which can be upgraded to dual enthalpy easily in the field. The economizer control has a minimum position set point, an outdoor-air set point, a mixed-air set point, and a CO₂ set point. Barometric relief is standard on all economizers.

Power Exhaust is easily field-installed. The power exhaust is housed in the barometric relief opening and is easily slipped in with a plugin assembly. The wire harness to the economizer also has accommodations for a smoke detector.

The damper minimum position, actual damper position, power exhaust on/off set point, mixed air temperature limit set point, and Demand Controlled Ventilation (DCV) set point can be read and adjusted at the unit controller display or remotely through a network connection. The Space CO₂ level, mixed air temperature, and Economizer Status (free cooling available, single or dual enthalpy) can be read at the unit controller display or remotely through a network connection. Economizer faults will trigger a network alarm and can be read at the unit controller display or remotely through a network connection.

Roofcurb

The Russell® By Rheem roofcurb (36) is made for tool-less assembly at the jobsite by engaging tabs in slots of adjacent curb sides, which makes the assembly process quick and easy.

Refrigerant Leak Detection

In the event of a detected refrigerant leak, the refrigerant leak detection sensor will trigger mitigation procedure that shuts off the compressor(s) and turns on the indoor blower motor.

The sensor is installed on the bracket facing the filter rack. From the outside of the unit, the sensor is not visible.

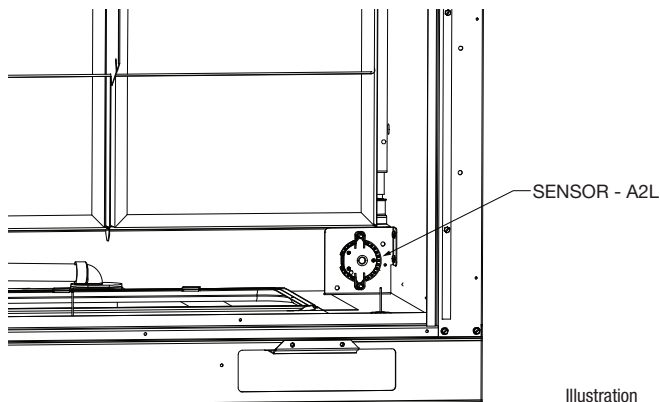

Illustration
ST-A1291-21-00

HUMIDIDRY DEHUMIDIFICATION SYSTEM

With the factory-installed dehumidification option, in addition to a thermostat or space temperature sensor that is normally present, an indoor relative humidity sensor is installed in the occupied space and connected to the Rooftop Unit Controller (RTU-C) which then controls the capacity of the cooling coil to remove moisture from the supply air and maintain space relative humidity below an adjustable limit visible on the RTU-C display. The default value is the ASHRAE recommended limit of 60% RH. With this option, a refrigerant reheat coil is installed downstream from the evaporator coil. When the space humidity is too high and reheat is energized, this coil uses some of the heat that is normally rejected to the outside by the condenser coil to instead reheat the cold air from the evaporator coil just enough to avoid overcooling and providing “neutral air” to the occupied space. On a two-stage system, it is possible for both a thermostat and humidistat to register readings above set point. Under this condition, the system runs in the high stage dehumidification cycle, and the VFD operates on high speed. This provides dry conditioned air.

Because the demand for dehumidification can be different from the cooling demand, the unit will first satisfy the demand for cooling and then if the space humidity is still too high, dehumidification mode is energized. When in dehumidification mode, the supply air leaving the unit will be near the entering air temperature, but at a much lower humidity. The unit will exit the dehumidification mode when the humidity set point is satisfied; or if the load is increased, it will return to normal cooling mode. Reheat is not available during the gas-heating mode.

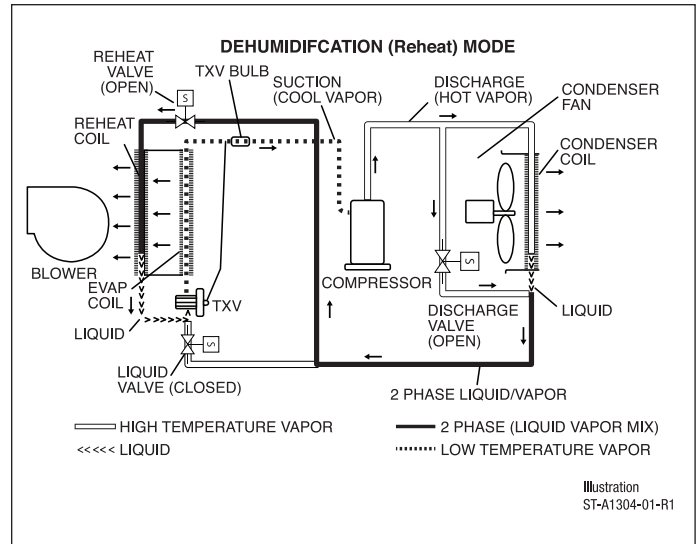

Figure 2 shows the refrigerant path during the reheat mode. When the reheat cycle is energized by the RTU-C, the reheat solenoid valve, upstream of the reheat coil opens. The liquid solenoid valve ahead of the TXV, closes. The discharge solenoid valve, in the compressor discharge line, opens. The liquid refrigerant leaves the TXV with the sudden pressure drop causing the liquid to expand to a vapor and absorbing the heat from the supply air going through the evaporator coil. The refrigerant vapor then travels to the compressor where it is elevated to a higher pressure and temperature. The refrigerant next carries the heat to a parallel path between the outside condenser coil and a bypass circuit. Some of the heat is rejected outdoor. The ratio of heat rejected outdoors versus indoors is controlled by an outdoor fan motor controller (OFMC) that monitors the two-phase temperature and varies the fan speed. This 2-phase refrigerant vapor is then sent to the reheat coil. As the refrigerant travels through the reheat coil it condenses into a subcooled liquid where the process repeats itself.

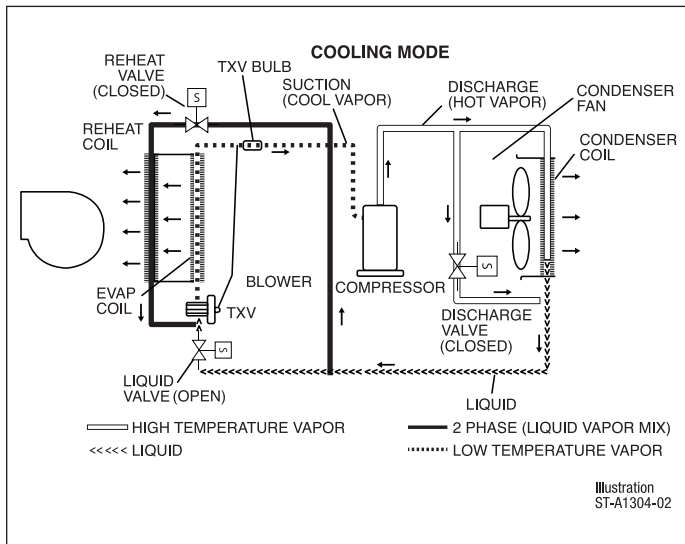

Figure 1 shows the refrigerant path during the normal cooling mode. The liquid refrigerant leaves the TXV with the sudden pressure drop causing the liquid to expand to a vapor and absorbing the heat from the supply air going through the evaporator coil. The refrigerant vapor then travels to the compressor where it is elevated to a higher pressure and temperature. The superheated refrigerant vapor next carries the heat to the outside coil where the heat is then rejected and the refrigerant condenses into a subcooled liquid where the process repeats itself.

R **GE** **C** **Y** **B** **036** **A** **C** **T** **10** **2** **A** **A** *******
1 **23** **4** **5** **6** **789** **10** **11** **12** **13 14** **15** **16** **17** **18 19 20**

1—Brand

R = Russell® By Rheem

2, 3—Unit Type

GE = Packaged Gas Electric

4—Cabinet Type

C = Small Commercial

5—Refrigerant

Y = R-454B

6—Efficiency Level

B = Standard Efficiency

7, 8, 9—Capacity

036 = 3 Ton

048 = 4 Ton

060 = 5 Ton

072 = 6 Ton

10—Major series

A = 1st Design

11—Voltage

J = 1 PH, 208-230 V, 60 Hz¹

C = 3 PH, 208-230 V, 60 Hz

D = 3 PH, 460 V, 60 Hz

Y = 3 PH, 575 V, 60 Hz²

12—Drive

T = Direct Drive Standard Static
Constant Torque

U = Direct Drive High Static
Constant Torque³

13, 14—Heat Capacity

07 = 75,000 Btu/h

10 = 100,000 Btu/h

12 = 125,000 Btu/h

15—Heat Configuration

2 = 2 Stage

B = 2 Stage Stainless

16—Control

A = CoreCommand™
(Non-Communicating)

B = CoreCommand &
Comfort Alert®

C = ClearControl™ (DDC)

D = ClearControl (DDC) &
Comfort Alert

17—Minor series

A = 1st Design

18, 19, 20—Option Code

See next page

NOTES:

1. J voltage is not available on 6 ton models.
2. Y voltage is not available on HumidiDry® models.
3. U drive is not available with J voltage.

Comfort Alert® is a registered trademark owned by Copeland LP

FACTORY-INSTALLED OPTION CODES FOR RGEC (3 TO 6 TON)

18	19	20
LV = Louver protection	LF = Low Ambient/Freeze Stat	EC = Economizer
RH ¹ = HumidiDry/HGRH (Hot Gas Reheat)	NP = Non-powered Convenience Outlet	SS = Supply and Return Smoke Detector
HA = Hinged Access	DC = Disconnect Switch	RS = Return Smoke Detector
CC ² = Coil Coating		

Option code character highlighted below

A	None				A	None			0	None		
B	LV				B	LF			1	EC		
C	HA				C	NP			2	RS		
D	LV	HA			D	LF	NP		3	EC	RS	
E	LV	CC			E	DC			4	SS	RS	
F	LV	HA	CC		F	LF	DC		5	EC	SS	RS
N	RH				H	NP	DC					
P	LV	RH			K	LF	NP	DC				
Q	RH	HA										
R	LV	RH	CC									
S	LV	RH	HA									
T	LV	RH	HA	CC								

¹RH Models with DDC Controls must include Low Ambient/Freeze Stat (LF)

²CC-requires LV (louver protection)

Instructions for Factory-Installed Option(s) Selection

Note: Three characters following the model number will be utilized to designate a factory-installed option or combination of options. If no factory option(s) is required, "AAO" follows the model number.

- **Step 1:** In the table above, based on the desired features, choose option code character from highlighted options on the left side under the number 18. For example, the option code character "E" has Louver protection and Coil Coating.
- **Step 2:** In the table above, based on the desired features, choose option code character from highlighted options on the left side under the number 19. For example, the option code character "F" has Low Ambient / Freeze Stat and Disconnect switch.
- **Step 3:** In the table above, based on the desired features, choose option code character from highlighted options on the left side under the number 20. For example, the option code character "3" has Economizer and Return Smoke.
- The resulting option code from examples above is: "EF3"
- **Step 4:** Add your option code selection to the end of model number

○ Example: RGECYB036ACC152AA EF3 = RGECYB036ACC152AAEF3

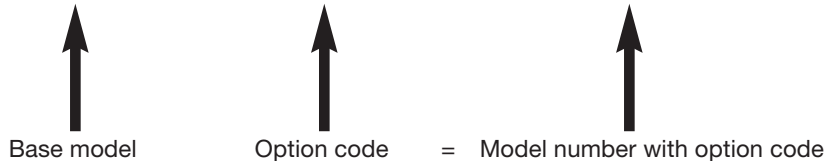

To select an RGEC Cooling and Heating unit to meet a job requirement, follow this procedure, with example, using data supplied in this specification sheet.

1. DETERMINE COOLING AND HEATING REQUIREMENTS AND SPECIFIC OPERATING CONDITIONS FROM PLANS AND SPECS.

Example:

Voltage—	230 V – 3 Phase – 60 Hz
Total Cooling Capacity—	47,000 BTUH [13.8 kW]
Sensible Cooling Capacity—	36,000 BTUH [10.6 kW]
Heating Capacity—	75,000 BTUH [22 kW]
*Condenser Entering Air—	95°F [35.0°C] DB
*Evaporator Mixed Air Entering—	67°F [19.4°C] WB 78°F [25.6°C] DB
*Indoor Air Flow (vertical)—	1600 CFM [755 L/s]
*External Static Pressure—	0.6 in. WG [.15 kPa]

2. SELECT UNIT TO MEET COOLING REQUIREMENTS.

Since total cooling is within range of a nominal 4-ton unit, use the cooling performance table at 95°F DB condenser inlet air. Interpolate between 1730 CFM [816 L/s] and 1400 CFM [660 L/s] to determine total and sensible capacity and Depression Ratio for inlet air at 1600CFM [755 L/s] indoor airflow (table basis)

Interpolation Formula:

$$MBH_1 + \left[(CFM - CFM_1) \times \left(\frac{MBH_2 - MBH_1}{CFM_2 - CFM_1} \right) \right] = MBH$$

Total Cooling Capacity:

$$46,800 + \left[(1,600 - 1,730) \times \left(\frac{45,200 - 46,800}{1,400 - 1,730} \right) \right] = 46,170 \text{ BTUH}$$

Total Cooling Capacity = 46,170 BTUH [13.5 kW]
Sensible Cooling Capacity = 33,7400 BTUH [9.9 kW]
DR = 0.2

When the entering dry bulb temperature (dbE) is not 80°F [26.7°C], the sensible capacity needs to be adjusted.

Note: total capacity is unaffected

Sensible Capacity Depression Formula:

$$Cap_{sensible} + [1.10 \times CFM \times (1 - DR) \times (dbE - 80)]$$

$$= 30,924 + [1.10 \times 1,600 \times (1 - 0.2) \times (78 - 80)]$$

Sensible Cooling Capacity = 30,924 BTUH [9.1 kW]

3. DETERMINE BLOWER SPEED AND BHP TO MEET SYSTEM DESIGN.

Total ESP (external static pressure) per the spec of 0.6 in WG [.15 kPa] includes the system duct and grilles. Add from the table “Component Air Resistance,” 0.13 in. WG [0.04 kPa] for wet coil. Using the “Airflow Performance Table”, at the specified 1,600 CFM and 0.7 in. WG [0.17 kPa] ESP, determine blower wattage.

CFM = 1564
Watts = 440
Tap = 5

4. CALCULATE INDOOR BLOWER BTUH HEAT EFFECT FROM MOTOR BHP IN STEP 3.

Assuming an average of 85% motor efficiency, determine the amount of heat generated by the blower motor at the specified CFM and ESP by dividing the watts used by the motor efficiency and solving for the difference. Convert this value from watts to BTUH, multiplying by 3.41 BTUH/Watt

Watts = 440

Avg. Motor Efficiency = 85%

$$\text{Indoor Blower Motor Heat} = \left[\left(\frac{\text{Watts}}{0.85} \right) - \text{Watts} \right] \times 3.41$$

$$= [(440/0.85) - 440] \times 3.41 = 77.6 \text{ BTUH [0.02 kW]}$$

5. CALCULATE THE NET COOLING CAPACITIES

Net cooling capacities can be calculated by subtracting the motor heat from the gross cooling capacities.

Net Total Capacity = Gross Total Capacity – Indoor Blower Motor Heat

$$= 46,170 - 77 = 46,093 \text{ BTUH [13.5 kW]}$$

Net Sensible Capacity = Gross Sensible Capacity – Indoor Blower Motor Heat

$$= 30,924 - 77 = 30,847 \text{ BTUH [9.0 kW]}$$

6. SELECT UNIT HEATING CAPACITY

For Gas Heating, choose the gas heat capacity that closest matches the specified heat capacity requirements. In this selection, the 75,000 BTU input is selected.

7. CHOOSE MODEL RGEC048ZTRACT07

[] Designates Metric Conversions

NOM. SIZES 3–6 TONS [10.6–21.1 kW]

Model RGECEB Series	036ACT 036ADT 036AJT	036ACU	036ADU	036AYT	036AYU
Cooling Performance^A					CONTINUED →
Cooling Capacity Btu/h [kW]	36,000 [10.55]	36,000 [10.55]	36,000 [10.55]	36,000 [10.55]	36,000 [10.55]
EER2/SEER2 ^B	10.6/13.4	10.6/13.4	10.6/13.4	10.6/13.4	10.6/13.4
Nominal CFM/AHRI Rated CFM [L/s]	1200/1175 [566/555]	1200/1175 [566/555]	1200/1175 [566/555]	1200/1175 [566/555]	1200/1175 [566/555]
AHRI Net Cooling Capacity Btu/h [kW]	34,200 [10.02]	34,200 [10.02]	34,200 [10.02]	34,200 [10.02]	34,200 [10.02]
Net Sensible Capacity Btu/h [kW]	25,600 [7.5]	25,600 [7.5]	25,600 [7.5]	25,600 [7.5]	25,600 [7.5]
Net Latent Capacity Btu/h [kW]	8,600 [2.52]	8,600 [2.52]	8,600 [2.52]	8,600 [2.52]	8,600 [2.52]
Net System Power kW	2.7	2.7	2.7	2.7	2.7
Compressor					
No./Type	1/Scroll	1/Scroll	1/Scroll	1/Scroll	1/Scroll
Outdoor Sound Rating (dB)^C					
	78	78	78	78	78
Outdoor Coil - Fin Type					
Tube Type	Louvered	Louvered	Louvered	Louvered	Louvered
MicroChannel Depth in. [mm]	MicroChannel	MicroChannel	MicroChannel	MicroChannel	MicroChannel
Face Area sq. ft. [sq. m]	0.71 [18]	0.71 [18]	0.71 [18]	0.71 [18]	0.71 [18]
Rows/FPI [FPcm]	16.46 [1.53]	16.46 [1.53]	16.46 [1.53]	16.46 [1.53]	16.46 [1.53]
	1/23 [9]	1/23 [9]	1/23 [9]	1/23 [9]	1/23 [9]
Indoor Coil - Fin Type					
Tube Type	Louvered	Louvered	Louvered	Louvered	Louvered
MicroChannel Depth in. [mm]	MicroChannel	MicroChannel	MicroChannel	MicroChannel	MicroChannel
Face Area sq. ft. [sq. m]	1 [25.4]	1 [25.4]	1 [25.4]	1 [25.4]	1 [25.4]
Rows/FPI [FPcm]	7.48 [0.69]	7.48 [0.69]	7.48 [0.69]	7.48 [0.69]	7.48 [0.69]
Refrigerant Control	1 / 20 [8]	1 / 20 [8]	1 / 20 [8]	1 / 20 [8]	1 / 20 [8]
Drain Connection No./Size in. [mm]	TX Valves	TX Valves	TX Valves	TX Valves	TX Valves
	1/0.75 [19.05]	1/0.75 [19.05]	1/0.75 [19.05]	1/0.75 [19.05]	1/0.75 [19.05]
Outdoor Fan - Type					
No. Used/Diameter in. [mm]	Propeller	Propeller	Propeller	Propeller	Propeller
Drive Type/No. Speeds	1/26 [660.4]	1/26 [660.4]	1/26 [660.4]	1/26 [660.4]	1/26 [660.4]
CFM [L/s]	Direct/1	Direct/1	Direct/1	Direct/1	Direct/1
No. Motors/HP	4250 [2006]	4250 [2006]	4250 [2006]	4250 [2006]	4250 [2006]
Motor RPM	1 at 1/5	1 at 1/5	1 at 1/5	1 at 1/5	1 at 1/5
	850	850	850	850	850
Indoor Fan - Type					
No. Used/Diameter in. [mm]	FC Centrifugal	FC Centrifugal	FC Centrifugal	FC Centrifugal	FC Centrifugal
Drive Type	1/11x11 [279x279]	1/11x11 [279x279]	1/11x11 [279x279]	1/11x11 [279x279]	1/11x11 [279x279]
No. Speeds	Direct	Direct	Direct	Direct	Direct
No. Motors	Multiple	Multiple	Multiple	Multiple	Multiple
Motor HP	1	1	1	1	1
Motor RPM	3/4	1-1/2	1	3/4	1-1/2
Motor Frame Size	1050	1050	1050	1050	1050
	48	48	48	48	48
Filter - Type					
Furnished	Disposable	Disposable	Disposable	Disposable	Disposable
(NO.) Size Recommended in. [mm x mm x mm]	Yes	Yes	Yes	Yes	Yes
	(4)2x16x16 [51x406x406]	(4)2x16x16 [51x406x406]	(4)2x16x16 [51x406x406]	(4)2x16x16 [51x406x406]	(4)2x16x16 [51x406x406]
Refrigerant Charge Oz. [g]					
	72 [2041]	72 [2041]	72 [2041]	72 [2041]	72 [2041]
Weights					
Net Weight lbs. [kg]	556 [252]	562 [255]	562 [255]	606 [275]	612 [278]
Ship Weight lbs. [kg]	594 [269]	600 [272]	600 [272]	644 [292]	650 [295]

See Page 18 for Notes.

[] Designates Metric Conversions

NOM. SIZES 3–6 TONS [10.6–21.1 kW]

Model RGECE Series	048ACT 048ADT 048AJT	048ACU	048ADU	048AYT	048AYU
Cooling Performance^A					CONTINUED →
Cooling Capacity Btu/h [kW]	48,000 [14.07]	48,000 [14.07]	48,000 [14.07]	48,000 [14.07]	48,000 [14.07]
EER2/SEER2 ^B	10.6/13.4	10.6/13.4	10.6/13.4	10.6/13.4	10.6/13.4
Nominal CFM/AHRI Rated CFM [L/s]	1600/1570 [755/741]	1600/1570 [755/741]	1600/1570 [755/741]	1600/1570 [755/741]	1600/1570 [755/741]
AHRI Net Cooling Capacity Btu/h [kW]	45,500 [13.33]	45,500 [13.33]	45,500 [13.33]	45,500 [13.33]	45,500 [13.33]
Net Sensible Capacity Btu/h [kW]	34,200 [10.02]	34,200 [10.02]	34,200 [10.02]	34,200 [10.02]	34,200 [10.02]
Net Latent Capacity Btu/h [kW]	11,300 [3.31]	11,300 [3.31]	11,300 [3.31]	11,300 [3.31]	11,300 [3.31]
Net System Power kW	3.8	3.8	3.8	3.8	3.8
Compressor					
No./Type	1/Scroll	1/Scroll	1/Scroll	1/Scroll	1/Scroll
Outdoor Sound Rating (dB)^C	85.3	85.3	85.3	85.3	85.3
Outdoor Coil - Fin Type	Louvered	Louvered	Louvered	Louvered	Louvered
Tube Type	MicroChannel	MicroChannel	MicroChannel	MicroChannel	MicroChannel
MicroChannel Depth in. [mm]	0.71 [18]	0.71 [18]	0.71 [18]	0.71 [18]	0.71 [18]
Face Area sq. ft. [sq. m]	16.46 [1.53]	16.46 [1.53]	16.46 [1.53]	16.46 [1.53]	16.46 [1.53]
Rows/FPI [FPcm]	1/23 [9]	1/23 [9]	1/23 [9]	1/23 [9]	1/23 [9]
Indoor Coil - Fin Type	Louvered	Louvered	Louvered	Louvered	Louvered
Tube Type	MicroChannel	MicroChannel	MicroChannel	MicroChannel	MicroChannel
MicroChannel Depth in. [mm]	1.26 [32]	1.26 [32]	1.26 [32]	1.26 [32]	1.26 [32]
Face Area sq. ft. [sq. m]	8.41 [0.78]	8.41 [0.78]	8.41 [0.78]	8.41 [0.78]	8.41 [0.78]
Rows/FPI [FPcm]	1 / 20 [8]	1 / 20 [8]	1 / 20 [8]	1 / 20 [8]	1 / 20 [8]
Refrigerant Control	TX Valves	TX Valves	TX Valves	TX Valves	TX Valves
Drain Connection No./Size in. [mm]	1/0.75 [19.05]	1/0.75 [19.05]	1/0.75 [19.05]	1/0.75 [19.05]	1/0.75 [19.05]
Outdoor Fan - Type	Propeller	Propeller	Propeller	Propeller	Propeller
No. Used/Diameter in. [mm]	1/26 [660.4]	1/26 [660.4]	1/26 [660.4]	1/26 [660.4]	1/26 [660.4]
Drive Type/No. Speeds	Direct/1	Direct/1	Direct/1	Direct/1	Direct/1
CFM [L/s]	5900 [2784]	5900 [2784]	5900 [2784]	5900 [2784]	5900 [2784]
No. Motors/HP	1 at 1/2 HP	1 at 1/2 HP	1 at 1/2 HP	1 at 1/2 HP	1 at 1/2 HP
Motor RPM	1075	1075	1075	1075	1075
Indoor Fan - Type	FC Centrifugal	FC Centrifugal	FC Centrifugal	FC Centrifugal	FC Centrifugal
No. Used/Diameter in. [mm]	1/11x11 [279x279]	1/11x11 [279x279]	1/11x11 [279x279]	1/11x11 [279x279]	1/11x11 [279x279]
Drive Type	Direct	Direct	Direct	Direct	Direct
No. Speeds	Multiple	Multiple	Multiple	Multiple	Multiple
No. Motors	1	1	1	1	1
Motor HP	3/4	1-1/2	1	3/4	1-1/2
Motor RPM	1050	1050	1050	1050	1050
Motor Frame Size	48	48	48	48	48
Filter - Type	Disposable	Disposable	Disposable	Disposable	Disposable
Furnished	Yes	Yes	Yes	Yes	Yes
(NO.) Size Recommended in. [mm x mm x mm]	(4)2x16x16 [51x406x406]	(4)2x16x16 [51x406x406]	(4)2x16x16 [51x406x406]	(4)2x16x16 [51x406x406]	(4)2x16x16 [51x406x406]
Refrigerant Charge Oz. [g]	67 [1899]	67 [1899]	67 [1899]	67 [1899]	67 [1899]
Weights					
Net Weight lbs. [kg]	583 [264]	589 [267]	589 [267]	633 [287]	639 [290]
Ship Weight lbs. [kg]	621 [282]	627 [284]	627 [284]	671 [304]	677 [307]

See Page 18 for Notes.

[] Designates Metric Conversions

NOM. SIZES 3–6 TONS [10.6–21.1 kW]

Model RGECE Series	060ACT 060ADT 060AJT	060ACU	060ADU	060AYT	060AYU
Cooling Performance^A					CONTINUED →
Cooling Capacity Btu/h [kW]	60,000 [17.58]	60,000 [17.58]	60,000 [17.58]	60,000 [17.58]	60,000 [17.58]
EER2/SEER2 ^B	10.6/13.4	10.6/13.4	10.6/13.4	10.6/13.4	10.6/13.4
Nominal CFM/AHRI Rated CFM [L/s]	2000/1825 [944/861]	2000/1825 [944/861]	2000/1825 [944/861]	2000/1825 [944/861]	2000/1825 [944/861]
AHRI Net Cooling Capacity Btu/h [kW]	57,000 [16.71]	57,000 [16.71]	57,000 [16.71]	57,000 [16.71]	57,000 [16.71]
Net Sensible Capacity Btu/h [kW]	43,000 [12.6]	43,000 [12.6]	43,000 [12.6]	43,000 [12.6]	43,000 [12.6]
Net Latent Capacity Btu/h [kW]	14,000 [4.1]	14,000 [4.1]	14,000 [4.1]	14,000 [4.1]	14,000 [4.1]
Net System Power kW	5.0	5.0	5.0	5.0	5.0
Compressor					
No./Type	1/Scroll	1/Scroll	1/Scroll	1/Scroll	1/Scroll
Outdoor Sound Rating (dB)^C	86	86	86	86	86
Outdoor Coil - Fin Type	Louvered	Louvered	Louvered	Louvered	Louvered
Tube Type	MicroChannel	MicroChannel	MicroChannel	MicroChannel	MicroChannel
MicroChannel Depth in. [mm]	0.63 [16]	0.63 [16]	0.63 [16]	0.63 [16]	0.63 [16]
Face Area sq. ft. [sq. m]	16.46 [1.53]	16.46 [1.53]	16.46 [1.53]	16.46 [1.53]	16.66 [1.55]
Rows/FPI [FPcm]	1/23 [9]	1/23 [9]	1/23 [9]	1/23 [9]	1/23 [9]
Indoor Coil - Fin Type	Louvered	Louvered	Louvered	Louvered	Louvered
Tube Type	MicroChannel	MicroChannel	MicroChannel	MicroChannel	MicroChannel
MicroChannel Depth in. [mm]	1.26 [32]	1.26 [32]	1.26 [32]	1.26 [32]	1.26 [32]
Face Area sq. ft. [sq. m]	8.41 [0.78]	8.41 [0.78]	8.41 [0.78]	8.41 [0.78]	8.41 [0.78]
Rows/FPI [FPcm]	1 / 20 [8]	1 / 20 [8]	1 / 20 [8]	1 / 20 [8]	1 / 20 [8]
Refrigerant Control	TX Valves	TX Valves	TX Valves	TX Valves	TX Valves
Drain Connection No./Size in. [mm]	1/0.75 [19.05]	1/0.75 [19.05]	1/0.75 [19.05]	1/0.75 [19.05]	1/0.75 [19.05]
Outdoor Fan - Type	Propeller	Propeller	Propeller	Propeller	Propeller
No. Used/Diameter in. [mm]	1/26 [660.4]	1/26 [660.4]	1/26 [660.4]	1/26 [660.4]	1/26 [660.4]
Drive Type/No. Speeds	Direct/1	Direct/1	Direct/1	Direct/1	Direct/1
CFM [L/s]	5900 [2784]	5900 [2784]	5900 [2784]	5900 [2784]	5900 [2784]
No. Motors/HP	1 at 1/2	1 at 1/2	1 at 1/2	1 at 1/2	1 at 1/2 HP
Motor RPM	1075	1075	1075	1075	1075
Indoor Fan - Type	FC Centrifugal	FC Centrifugal	FC Centrifugal	FC Centrifugal	FC Centrifugal
No. Used/Diameter in. [mm]	1/11x11 [279x279]	1/11x11 [279x279]	1/11x11 [279x279]	1/11x11 [279x279]	1/11x11 [279x279]
Drive Type	Direct	Direct	Direct	Direct	Direct
No. Speeds	Multiple	Multiple	Multiple	Multiple	Multiple
No. Motors	1	1	1	1	1
Motor HP	1	1-1/2	1-1/5	1	1-1/2
Motor RPM	1050	1050	1050	1050	1050
Motor Frame Size	48	48	48	48	48
Filter - Type	Disposable	Disposable	Disposable	Disposable	Disposable
Furnished	Yes	Yes	Yes	Yes	Yes
(NO.) Size Recommended in. [mm x mm x mm]	(4)2x16x16 [51x406x406]	(4)2x16x16 [51x406x406]	(4)2x16x16 [51x406x406]	(4)2x16x16 [51x406x406]	(4)2x16x16 [51x406x406]
Refrigerant Charge Oz. [g]	80 [2268]	80 [2268]	80 [2268]	80 [2268]	80 [2268]
Weights					
Net Weight lbs. [kg]	586 [266]	592 [269]	592 [269]	636 [288]	642 [291]
Ship Weight lbs. [kg]	624 [283]	630 [286]	630 [286]	674 [306]	680 [308]

See Page 18 for Notes.

[] Designates Metric Conversions

NOM. SIZES 3–6 TONS [10.6–21.1 kW]

Model RGECYB Series	072ACT 072ADT	072ACU 072ADU	072ADU	072AYT	072AYU
Cooling Performance^A					
Cooling Capacity Btu/h [kW]	72000 [21.1]	72000 [21.1]	72000 [21.1]	72000 [21.1]	72000 [21.1]
EER/IEERP	11.0/14.6	11.0/14.6	11.0/14.6	11.0/14.6	11.0/14.6
Nominal CFM/AHRI Rated CFM [L/s]	2400/2400 [1133/1133]	2400/2400 [1133/1133]	2400/2400 [1133/1133]	2400/2400 [1133/1133]	2400/2400 [1133/1133]
AHRI Net Cooling Capacity Btu/h [kW]	68500 [20.08]	68500 [20.08]	68500 [20.08]	68500 [20.08]	68500 [20.08]
Net Sensible Capacity Btu/h [kW]	51500 [15.09]	51500 [15.09]	51500 [15.09]	51500 [15.09]	51500 [15.09]
Net Latent Capacity Btu/h [kW]	17000 [4.98]	17000 [4.98]	17000 [4.98]	17000 [4.98]	17000 [4.98]
Net System Power kW	6.2	6.2	6.2	6.2	6.2
Compressor					
No./Type	1/Scroll	1/Scroll	1/Scroll	1/Scroll	1/Scroll
Outdoor Sound Rating (dB)^C					
	85	85	85	85	85
Outdoor Coil - Fin Type					
Tube Type	Louvered	Louvered	Louvered	Louvered	Louvered
MicroChannel Depth in. [mm]	MicroChannel	MicroChannel	MicroChannel	MicroChannel	MicroChannel
Face Area sq. ft. [sq. m]	0.71 [18]	0.71 [18]	0.71 [18]	0.71 [18]	0.71 [18]
Rows/FPI [FPcm]	16.46 [1.53]	16.46 [1.53]	16.46 [1.53]	16.46 [1.53]	16.46 [1.53]
	1/23 [9]	1/23 [9]	1/23 [9]	1/23 [9]	1/23 [9]
Indoor Coil - Fin Type					
Tube Type	Louvered	Louvered	Louvered	Louvered	Louvered
MicroChannel Depth in. [mm]	MicroChannel	MicroChannel	MicroChannel	MicroChannel	MicroChannel
Face Area sq. ft. [sq. m]	1.26 [32]	1.26 [32]	1.26 [32]	1.26 [32]	1.26 [32]
Rows/FPI [FPcm]	8.41 [0.78]	8.41 [0.78]	8.41 [0.78]	8.41 [0.78]	8.41 [0.78]
Refrigerant Control	1 / 20 [8]	1 / 20 [8]	1 / 20 [8]	1 / 20 [8]	1 / 20 [8]
Drain Connection No./Size in. [mm]	TX Valves	TX Valves	TX Valves	TX Valves	TX Valves
	1/0.75 [19.05]	1/0.75 [19.05]	1/0.75 [19.05]	1/0.75 [19.05]	1/0.75 [19.05]
Outdoor Fan - Type					
No. Used/Diameter in. [mm]	Propeller	Propeller	Propeller	Propeller	Propeller
Drive Type/No. Speeds	1/26 [660.4]	1/26 [660.4]	1/26 [660.4]	1/26 [660.4]	1/26 [660.4]
CFM [L/s]	Direct/1	Direct/1	Direct/1	Direct/1	Direct/1
No. Motors/HP	5900 [2784]	5900 [2784]	5900 [2784]	5900 [2784]	5900 [2784]
Motor RPM	1 at 3/4	1 at 3/4	1 at 3/4	1 at 3/4	1 at 3/4
	1100	1100	1100	1100	1100
Indoor Fan - Type					
No. Used/Diameter in. [mm]	FC Centrifugal	FC Centrifugal	FC Centrifugal	FC Centrifugal	FC Centrifugal
Drive Type	1/11x11 [279x279]	1/11x11 [279x279]	1/11x11 [279x279]	1/11x11 [279x279]	1/11x11 [279x279]
No. Speeds	Direct	Direct	Direct	Direct	Direct
No. Motors	Multiple	Multiple	Multiple	Multiple	Multiple
Motor HP	1	1	1	1	1
Motor RPM	1-1/5	1-1/5	1-1/5	1-1/5	1-1/5
Motor Frame Size	1300	1300	1300	1300	1300
	48	48	48	48	48
Filter - Type					
Furnished	Disposable	Disposable	Disposable	Disposable	Disposable
(NO.) Size Recommended in. [mm x mm x mm]	Yes	Yes	Yes	Yes	Yes
	(4)2x16x16 [51x406x406]	(4)2x16x16 [51x406x406]	(4)2x16x16 [51x406x406]	(4)2x16x16 [51x406x406]	(4)2x16x16 [51x406x406]
Refrigerant Charge Oz. [g]					
	85 [2410]	85 [2410]	85 [2410]	85 [2410]	85 [2410]
Weights					
Net Weight lbs. [kg]	586 [266]	592 [269]	592 [269]	636 [288]	642 [291]
Ship Weight lbs. [kg]	624 [283]	630 [286]	630 [286]	674 [306]	680 [308]

See Page 18 for Notes.

[] Designates Metric Conversions

NOTES:

- A. Cooling Performance is rated at 95°F ambient, 80°F entering dry bulb, 67°F entering wet bulb. Gross capacity does not include the effect of fan motor heat. AHRI capacity is net and includes the effect of fan motor heat. Units are suitable for operation to 20% of nominal cfm. Units are certified in accordance with the Unitary Air Conditioner Equipment certification program, which is based on AHRI Standard 210/240.
- B. EER/EER2 and/or SEER2 are rated at AHRI conditions and in accordance with DOE test procedures.
- C. Outdoor Sound Rating shown is tested in accordance with AHRI Standard 270.
- D. Integrated Energy Efficiency Ratio (IEER) is rated in accordance with AHRI Standard 340/360.

WEIGHTED SOUND POWER LEVEL (dBA)

Unit Size – Series	Standard Rating (dBA)	TYPICAL OCTAVE BAND SPECTRUM (dBA without tone adjustment)							
		63	125	250	500	1000	2000	4000	8000
RGECYB036	78.0	48.7	58.1	63.9	67.0	67.8	64.7	60.6	54.7
RGECYB048	85.3	58.2	64.7	75.1	74.7	75.5	72.3	67.8	61.0
RGECYB060	86.0	58.2	62.5	76.7	75.0	75.2	77.0	69.0	60.0
RGECYB072	85.0	54.9	67.3	69.4	73.8	73.4	71.2	69.6	65.3

Outdoor Sound Rating shown is tested in accordance with AHRI Standard 270.

RGECEYB HEATING PERFORMANCE

208-230V & 575V						
Tonnage	3-Ton		4-Ton		5-Ton	
Heating Input BTU/h [kW] (High-Fire / Low-Fire)	75,000/52,500 [21.98/115.39]	100,000/70,000 [29.31/20.52]	75,000/52,500 [21.98/115.39]	120,000/84,000 [35.17/24.62]	75,000/52,500 [21.98/115.39]	120,000/84,000 [35.17/24.62]
Heating Output BTU/h [kW] (High-Fire / Low-Fire)	60,750/42,525 [17.80/12.46]	81,000/56,700 [23.74/16.62]	60,750/42,525 [17.80/12.46]	97,200/68,040 [28.49/19.94]	60,750/42,525 [17.80/12.46]	97,200/68,040 [28.49/19.94]
High-Fire Rise Range °F [°C]	25-55 [13.9-30.6]	35-65 [19.4-36.1]	25-55 [13.9-30.6]	40-70 [22.2-38.9]	25-55 [13.9-30.6]	35-65 [22.2-38.9]
Low-Fire Rise Range °F [°C]	20-50 [11.1-27.8]	25-55 [13.9-30.6]	20-50 [11.1-27.8]	30-60 [16-33]	20-50 [11.1-27.8]	25-55 [13.9-30.6]
Main Limit Temp °F	145	125	145	125	145	125
Rollout Temp. °F	250	250	250	250	250	250
Rating ESP In. W.C.	0.33	0.28	0.33	0.28	0.33	0.28
Maximum ESP In. W.C.	0.80	0.80	0.80	0.80	0.80	0.80
Max Outlet Air Temp °F [°C]	180 [82.2]	190 [87.8]	180 [82.2]	180 [82.2]	180 [82.2]	180 [82.2]
% AFUE	81.0	81.0	81.0	81.0	81.0	81.0
% Steady State Efficiency	81.0	81.0	81.0	81.0	81.0	81.0
460V						
Tonnage	3-Ton		4-Ton		5-Ton	
Heating Input BTU/h [kW] (High-Fire / Low-Fire)	75,000/52,500 [21.98/115.39]	100,000/70,000 [29.31/20.52]	75,000/52,500 [21.98/115.39]	120,000/84,000 [35.17/24.62]	75,000/52,500 [21.98/115.39]	120,000/84,000 [35.17/24.62]
Heating Output BTU/h [kW] (High-Fire / Low-Fire)	60,750/42,525 [17.80/12.46]	81,000/56,700 [23.74/16.62]	60,750/42,525 [17.80/12.46]	97,200/68,040 [28.49/19.94]	60,750/42,525 [17.80/12.46]	97,200/68,040 [28.49/19.94]
High-Fire Rise Range °F [°C]	30-60 [16.7-33.3]	35-65 [19.4-36.1]	30-60 [16.7-33.3]	40-70 [22.2-38.9]	30-60 [16.7-33.3]	35-65 [19.4-36.1]
Low-Fire Rise Range °F [°C]	25-55 [13.9-30.6]	30-60 [16.7-33.3]	20-50 [11.1-27.8]	35-65 [19.4-36.1]	20-50 [11.1-27.8]	30-60 [16.7-33.3]
Main Limit Temp °F	145	125	145	125	145	125
Rollout Temp. °F	250	250	250	250	250	250
Rating ESP In. W.C.	0.33	0.28	0.33	0.28	0.33	0.28
Maximum ESP In. W.C.	0.80	0.80	0.80	0.80	0.80	0.80
Max Outlet Air Temp °F [°C]	180 [82.2]	190 [87.8]	180 [82.2]	180 [82.2]	180 [82.2]	180 [82.2]
% Steady State Efficiency	81.0	81.0	81.0	81.0	81.0	81.0

Gas Valve Connection Pipe Size In. [mm] .50 [12.7]

[] Designates Metric Conversions

RGECYB HEATING PERFORMANCE (CON'T.)

208-230V & 575V		
Tonnage	6-Ton	
Heating Input BTU/h [kW] (High-Fire / Low-Fire)	75,000/52,500 [21.98/115.39]	120,000/84,000 [35.17/24.62]
Heating Output BTU/h [kW] (High-Fire / Low-Fire)	60,750/42,525 [17.80/12.46]	97,200/68,040 [28.49/19.94]
High-Fire Rise Range °F [°C]	25-55 [13.9-30.6]	35-65 [22.2-38.9]
Low-Fire Rise Range °F [°C]	20-50 [11.1-27.8]	30-60 [16.7-33.3]
Main Limit Temp °F	145	125
Rollout Temp. °F	250	250
Rating ESP In. W.C.	0.33	0.28
Maximum ESP In. W.C.	0.80	0.80
Max Outlet Air Temp °F [°C]	180 [82.2]	180 [82.2]
% AFUE	81.0	81.0
% Steady State Efficiency	81.0	81.0
460V		
Tonnage	6-Ton	
Heating Input BTU/h [kW] (High-Fire / Low-Fire)	75,000/52,500 [21.98/115.39]	120,000/84,000 [35.17/24.62]
Heating Output BTU/h [kW] (High-Fire / Low-Fire)	60,750/42,525 [17.80/12.46]	97,200/68,040 [28.49/19.94]
High-Fire Rise Range °F [°C]	30-60 [16.7-33.3]	35-65 [19.4-36.1]
Low-Fire Rise Range °F [°C]	20-50 [11.1-27.8]	30-60 [16.7-33.3]
Main Limit Temp °F	145	125
Rollout Temp. °F	250	250
Rating ESP In. W.C.	0.33	0.28
Maximum ESP In. W.C.	0.80	0.80
Max Outlet Air Temp °F [°C]	180 [82.2]	180 [82.2]
% Steady State Efficiency	81.0	81.0

Gas Valve Connection Pipe Size In. [mm] .50 [12.7]

[] Designates Metric Conversions

COOLING PERFORMANCE DATA – RGECEYB036

RGECEYB036 - ENTERING INDOOR AIR @ 80°F [26.7°C] dbE ①											
wbE		71°F [21.7°C]			67°F [19.4°C]			63°F [17.2°C]			
CFM [L/s]		1325 [625]	1175 [555]	950 [448]	1325 [625]	1175 [555]	950 [448]	1325 [625]	1175 [555]	950 [448]	
DR ①		.05	.09	.12	.05	.09	.12	.05	.09	.12	
O U T D O O R D R Y B U L B T E M P E R A T U R E [°F] [°C]	75°F [23.9°C]	Total BTUH [kW] Sens BTUH [kW] Power	44.3 [13.0] 26.0 [7.6] 2.2	43.3 [12.7] 24.6 [7.2] 2.2	41.8 [12.3] 22.4 [6.6] 2.2	41.5 [12.2] 29.6 [8.7] 2.3	40.5 [11.9] 27.9 [8.2] 2.2	39.1 [11.5] 25.4 [7.4] 2.2	39.1 [11.5] 33.7 [9.9] 2.2	38.2 [11.2] 31.8 [9.3] 2.2	36.9 [10.8] 28.9 [8.5] 2.2
	80°F [26.7°C]	Total BTUH [kW] Sens BTUH [kW] Power	43.0 [12.6] 25.5 [7.5] 2.4	42.0 [12.3] 24.0 [7.0] 2.3	40.6 [11.9] 21.9 [6.4] 2.3	40.2 [11.8] 29.0 [8.5] 2.4	39.3 [11.5] 27.4 [8.0] 2.4	37.9 [11.1] 24.9 [7.3] 2.3	37.8 [11.1] 33.1 [9.7] 2.4	37.0 [10.8] 31.3 [9.2] 2.3	35.7 [10.5] 28.5 [8.4] 2.3
	85°F [29.4°C]	Total BTUH [kW] Sens BTUH [kW] Power	41.7 [12.2] 24.8 [7.3] 2.5	40.7 [11.9] 23.4 [6.9] 2.5	39.3 [11.5] 21.3 [6.2] 2.4	38.8 [11.4] 28.4 [8.3] 2.5	37.9 [11.1] 26.8 [7.9] 2.5	36.6 [10.7] 24.4 [7.2] 2.4	36.5 [10.7] 32.5 [9.5] 2.5	35.7 [10.5] 30.6 [9.0] 2.5	34.4 [10.1] 27.9 [8.2] 2.4
	90°F [32.2°C]	Total BTUH [kW] Sens BTUH [kW] Power	40.2 [11.8] 24.1 [7.1] 2.6	39.3 [11.5] 22.7 [6.7] 2.6	38.0 [11.1] 20.7 [6.1] 2.5	37.4 [11.0] 27.7 [8.1] 2.6	36.5 [10.7] 26.1 [7.6] 2.6	35.3 [10.3] 23.8 [7.0] 2.6	35.0 [10.3] 31.7 [9.3] 2.6	34.3 [10.1] 30.0 [8.8] 2.6	33.1 [9.7] 27.3 [8.0] 2.6
	95°F [35°C]	Total BTUH [kW] Sens BTUH [kW] Power	38.7 [11.3] 23.3 [6.8] 2.7	37.9 [11.1] 22.0 [6.4] 2.7	36.5 [10.7] 20.0 [5.9] 2.7	35.9 [10.5] 26.9 [7.9] 2.8	35.1 [10.3] 25.3 [7.4] 2.7	33.8 [9.9] 23.1 [6.8] 2.7	33.5 [9.8] 31.0 [9.1] 2.8	32.8 [9.6] 29.2 [8.6] 2.7	31.6 [9.3] 26.6 [7.8] 2.7
	100°F [37.8°C]	Total BTUH [kW] Sens BTUH [kW] Power	37.2 [10.9] 22.4 [6.6] 2.9	36.3 [10.6] 21.2 [6.2] 2.8	35.0 [10.3] 19.3 [5.7] 2.8	34.3 [10.1] 26.0 [7.6] 2.9	33.5 [9.8] 24.5 [7.2] 2.9	32.4 [9.5] 22.3 [6.5] 2.8	32.0 [9.4] 30.1 [8.8] 2.9	31.2 [9.1] 28.4 [8.3] 2.9	30.2 [8.9] 25.9 [7.6] 2.8
	105°F [40.6°C]	Total BTUH [kW] Sens BTUH [kW] Power	35.5 [10.4] 21.5 [6.3] 3.0	34.7 [10.2] 20.3 [5.9] 3.0	33.5 [9.8] 18.5 [5.4] 2.9	32.7 [9.6] 25.0 [7.3] 3.0	31.9 [9.3] 23.6 [6.9] 3.0	30.8 [9.0] 21.5 [6.3] 2.9	30.3 [8.9] 29.1 [8.5] 3.0	29.6 [8.7] 27.5 [8.1] 3.0	28.6 [8.4] 25.0 [7.3] 2.9
	110°F [43.3°C]	Total BTUH [kW] Sens BTUH [kW] Power	33.8 [9.9] 20.5 [6.0] 3.1	33.0 [9.7] 19.3 [5.7] 3.1	31.9 [9.3] 17.6 [5.2] 3.1	30.9 [9.1] 24.0 [7.0] 3.2	30.2 [8.9] 22.7 [6.7] 3.1	29.2 [8.6] 20.6 [6.0] 3.1	28.6 [8.4] 28.1 [8.2] 3.2	27.9 [8.2] 26.5 [7.8] 3.1	27.0 [7.9] 24.2 [7.1] 3.1
	115°F [46.1°C]	Total BTUH [kW] Sens BTUH [kW] Power	32.0 [9.4] 19.4 [5.7] 3.3	31.3 [9.2] 18.3 [5.4] 3.2	30.2 [8.9] 16.6 [4.9] 3.2	29.1 [8.5] 22.9 [6.7] 3.3	28.5 [8.4] 21.6 [6.3] 3.3	27.5 [8.1] 19.7 [5.8] 3.2	26.8 [7.9] 26.8 [7.9] 3.3	26.2 [7.7] 25.5 [7.5] 3.2	25.3 [7.4] 23.2 [6.8] 3.2
	120°F [48.9°C]	Total BTUH [kW] Sens BTUH [kW] Power	30.1 [8.8] 18.2 [5.3] 3.4	29.4 [8.6] 17.2 [5.0] 3.4	28.4 [8.3] 15.6 [4.6] 3.3	27.3 [8.0] 21.7 [6.4] 3.4	26.7 [7.8] 20.5 [6.0] 3.4	25.7 [7.5] 18.7 [5.5] 3.3	24.9 [7.3] 24.9 [7.3] 3.4	24.4 [7.2] 24.4 [7.2] 3.4	23.5 [6.9] 22.2 [6.5] 3.3
125°F [51.7°C]	Total BTUH [kW] Sens BTUH [kW] Power	28.2 [8.3] 16.9 [5.0] 3.5	27.5 [8.1] 16.0 [4.7] 3.5	26.6 [7.8] 14.6 [4.3] 3.4	25.3 [7.4] 20.5 [6.0] 3.6	24.8 [7.3] 19.3 [5.7] 3.5	23.9 [7.0] 17.6 [5.2] 3.5	23.0 [6.7] 23.0 [6.7] 3.5	22.5 [6.6] 22.5 [6.6] 3.5	21.7 [6.4] 21.1 [6.2] 3.4	

DR —Depression ratio
dbE —Entering air dry bulb
wbE —Entering air wet bulb

Total —Total capacity x 1000 BTUH
Sens —Sensible capacity x 1000 BTUH
Power —KW input

NOTES: ① When the entering air dry bulb is other than 80°F [27°C], adjust the sensible capacity from the table by adding [1.10 x CFM x (1 – DR) x (dbE – 80)].

[] Designates Metric Conversions

COOLING PERFORMANCE DATA – RGECYB048

RGECYB048 - ENTERING INDOOR AIR @ 80°F [26.7°C] dbE ①												
wbE		71°F [21.7°C]			67°F [19.4°C]			63°F [17.2°C]				
CFM [L/s]		1775 [838]	1575 [743]	1275 [602]	1775 [838]	1575 [743]	1275 [602]	1775 [838]	1575 [743]	1275 [602]		
DR ①		.05	.09	.12	.05	.09	.12	.05	.09	.12		
O U T D O O R D R Y B U L B T E M P E R A T U R E	75°F [23.9°C]	Total BTUH [kW]	57.1 [16.7]	55.8 [16.4]	53.9 [15.8]	54.2 [15.9]	53.0 [15.5]	51.2 [15.0]	51.4 [15.1]	50.2 [14.7]	48.5 [14.2]	
		Sens BTUH [kW]	33.2 [9.7]	31.4 [9.2]	28.6 [8.4]	38.6 [11.3]	36.5 [10.7]	33.2 [9.7]	44.0 [12.9]	41.5 [12.2]	37.8 [11.1]	
		Power	3.4	3.4	3.3	3.4	3.4	3.3	3.4	3.3	3.3	
	80°F [26.7°C]	Total BTUH [kW]	55.7 [16.3]	54.4 [15.9]	52.5 [15.4]	52.8 [15.5]	51.6 [15.1]	49.9 [14.6]	50.0 [14.7]	48.9 [14.3]	47.2 [13.8]	45.8 [13.4]
		Sens BTUH [kW]	32.4 [9.5]	30.6 [9.0]	27.9 [8.2]	37.8 [11.1]	35.7 [10.5]	32.5 [9.5]	43.2 [12.7]	40.7 [11.9]	37.1 [10.9]	
		Power	3.5	3.5	3.4	3.6	3.5	3.5	3.5	3.5	3.4	
	85°F [29.4°C]	Total BTUH [kW]	54.3 [15.9]	53.1 [15.6]	51.2 [15.0]	51.4 [15.1]	50.3 [14.7]	48.5 [14.2]	48.6 [14.2]	47.5 [13.9]	45.8 [13.4]	44.5 [13.0]
		Sens BTUH [kW]	31.6 [9.3]	29.8 [8.7]	27.2 [8.0]	36.9 [10.8]	34.9 [10.2]	31.8 [9.3]	42.3 [12.4]	40.0 [11.7]	36.4 [10.7]	
		Power	3.7	3.6	3.6	3.7	3.7	3.6	3.7	3.6	3.6	
	90°F [32.2°C]	Total BTUH [kW]	52.9 [15.5]	51.7 [15.2]	49.9 [14.6]	50.0 [14.7]	48.9 [14.3]	47.2 [13.8]	47.2 [13.8]	46.1 [13.5]	44.5 [13.0]	43.2 [12.7]
		Sens BTUH [kW]	30.7 [9.0]	29.0 [8.5]	26.4 [7.7]	36.1 [10.6]	34.1 [10.0]	31.1 [9.1]	41.5 [12.2]	39.2 [11.5]	35.7 [10.5]	
		Power	3.8	3.8	3.7	3.8	3.8	3.7	3.8	3.7	3.7	
95°F [35°C]	Total BTUH [kW]	51.5 [15.1]	50.3 [14.7]	48.6 [14.2]	48.6 [14.2]	47.5 [13.9]	45.9 [13.5]	45.8 [13.4]	44.8 [13.1]	43.2 [12.7]	41.9 [12.3]	
	Sens BTUH [kW]	29.9 [8.8]	28.2 [8.3]	25.7 [7.5]	35.3 [10.3]	33.3 [9.8]	30.3 [8.9]	40.7 [11.9]	38.4 [11.3]	35.0 [10.3]		
	Power	3.9	3.9	3.8	4.0	3.9	3.9	3.9	3.9	3.8		
100°F [37.8°C]	Total BTUH [kW]	50.1 [14.7]	49.0 [14.4]	47.3 [13.9]	47.2 [13.8]	46.2 [13.5]	44.6 [13.1]	44.4 [13.0]	43.4 [12.7]	41.9 [12.3]	40.6 [11.9]	
	Sens BTUH [kW]	29.1 [8.5]	27.4 [8.0]	25.0 [7.3]	34.5 [10.1]	32.5 [9.5]	29.6 [8.7]	39.8 [11.7]	37.6 [11.0]	34.3 [10.1]		
	Power	4.1	4.0	4.0	4.1	4.1	4.0	4.1	4.0	4.0		
105°F [40.6°C]	Total BTUH [kW]	48.7 [14.3]	47.6 [14.0]	45.9 [13.5]	45.8 [13.4]	44.8 [13.1]	43.3 [12.7]	43.0 [12.6]	42.0 [12.3]	40.6 [11.9]	39.3 [11.5]	
	Sens BTUH [kW]	28.2 [8.3]	26.7 [7.8]	24.3 [7.1]	33.6 [9.8]	31.7 [9.3]	28.9 [8.5]	39.0 [11.4]	36.8 [10.8]	33.5 [9.8]		
	Power	4.2	4.2	4.1	4.2	4.2	4.1	4.2	4.2	4.1		
110°F [43.3°C]	Total BTUH [kW]	47.3 [13.9]	46.2 [13.5]	44.6 [13.1]	44.4 [13.0]	43.4 [12.7]	41.9 [12.3]	41.6 [12.2]	40.6 [11.9]	39.2 [11.5]	37.9 [11.1]	
	Sens BTUH [kW]	27.4 [8.0]	25.9 [7.6]	23.6 [6.9]	32.8 [9.6]	31.0 [9.1]	28.2 [8.3]	38.2 [11.2]	36.0 [10.6]	32.8 [9.6]		
	Power	4.4	4.3	4.2	4.4	4.3	4.3	4.3	4.3	4.2		
115°F [46.1°C]	Total BTUH [kW]	45.9 [13.5]	44.9 [13.2]	43.3 [12.7]	43.0 [12.6]	42.1 [12.3]	40.6 [11.9]	40.2 [11.8]	39.3 [11.5]	37.9 [11.1]	36.6 [10.7]	
	Sens BTUH [kW]	26.6 [7.8]	25.1 [7.4]	22.9 [6.7]	32.0 [9.4]	30.2 [8.9]	27.5 [8.1]	37.3 [10.9]	35.2 [10.3]	32.1 [9.4]		
	Power	4.5	4.4	4.4	4.5	4.5	4.4	4.5	4.4	4.4		
120°F [48.9°C]	Total BTUH [kW]	44.5 [13.0]	43.5 [12.7]	42.0 [12.3]	41.6 [12.2]	40.7 [11.9]	39.3 [11.5]	38.8 [11.4]	37.9 [11.1]	36.6 [10.7]	35.3 [10.3]	
	Sens BTUH [kW]	25.7 [7.5]	24.3 [7.1]	22.1 [6.5]	31.1 [9.1]	29.4 [8.6]	26.8 [7.9]	36.5 [10.7]	34.5 [10.1]	31.4 [9.2]		
	Power	4.6	4.6	4.5	4.7	4.6	4.5	4.6	4.6	4.5		
125°F [51.7°C]	Total BTUH [kW]	43.1 [12.6]	42.1 [12.3]	40.7 [11.9]	40.2 [11.8]	39.3 [11.5]	38.0 [11.1]	37.4 [11.0]	36.5 [10.7]	35.3 [10.3]	34.0 [9.9]	
	Sens BTUH [kW]	24.9 [7.3]	23.5 [6.9]	21.4 [6.3]	30.3 [8.9]	28.6 [8.4]	26.1 [7.6]	35.7 [10.5]	33.7 [9.9]	30.7 [9.0]		
	Power	4.8	4.7	4.6	4.8	4.7	4.7	4.8	4.7	4.6		

DR —Depression ratio Total —Total capacity x 1000 BTUH NOTES: ① When the entering air dry bulb is other than 80°F [27°C], adjust the sensible capacity from the table by adding [1.10 x CFM x (1 – DR) x (dbE – 80)].
 dbE —Entering air dry bulb Sens —Sensible capacity x 1000 BTUH
 wbE—Entering air wet bulb Power —KW input

[] Designates Metric Conversions

COOLING PERFORMANCE DATA—RGECEYB060

RGECEYB060 - ENTERING INDOOR AIR @ 80°F [26.7°C] dbE ①											
wbE		71°F [21.7°C]			67°F [19.4°C]			63°F [17.2°C]			
CFM [L/s]		2200 [1038]	1825 [861]	1600 [755]	2200 [1038]	1825 [861]	1600 [755]	2200 [1038]	1825 [861]	1600 [755]	
DR ①		.05	.09	.12	.05	.09	.12	.05	.09	.12	
O U T D O O R D R Y B U L B T E M P E R A T U R E [°F] [°C]	75°F [23.9°C]	Total BTUH [kW] Sens BTUH [kW] Power	72.1 [21.1] 43.2 [12.7] 4.2	69.5 [20.4] 39.4 [11.5] 4.1	67.9 [19.9] 37.2 [10.9] 4.1	68.4 [20.0] 48.5 [14.2] 4.2	66.0 [19.3] 44.2 [13.0] 4.2	64.5 [18.9] 41.7 [12.2] 4.1	64.9 [19.0] 53.9 [15.8] 4.2	62.6 [18.3] 49.2 [14.4] 4.1	61.1 [17.9] 46.3 [13.6] 4.1
	80°F [26.7°C]	Total BTUH [kW] Sens BTUH [kW] Power	70.4 [20.6] 42.4 [12.4] 4.4	67.9 [19.9] 38.7 [11.3] 4.4	66.4 [19.5] 36.5 [10.7] 4.3	66.8 [19.6] 47.7 [14.0] 4.5	64.4 [18.9] 43.5 [12.7] 4.4	62.9 [18.4] 41.0 [12.0] 4.4	63.2 [18.5] 53.1 [15.6] 4.5	60.9 [17.8] 48.4 [14.2] 4.4	59.6 [17.5] 45.6 [13.4] 4.3
	85°F [29.4°C]	Total BTUH [kW] Sens BTUH [kW] Power	68.6 [20.1] 41.5 [12.2] 4.7	66.1 [19.4] 37.9 [11.1] 4.6	64.7 [19.0] 35.7 [10.5] 4.6	64.9 [19.0] 46.7 [13.7] 4.7	62.6 [18.3] 42.7 [12.5] 4.6	61.2 [17.9] 40.2 [11.8] 4.6	61.4 [18.0] 52.1 [15.3] 4.7	59.2 [17.4] 47.6 [14.0] 4.6	57.9 [17.0] 44.8 [13.1] 4.6
	90°F [32.2°C]	Total BTUH [kW] Sens BTUH [kW] Power	66.7 [19.5] 40.4 [11.8] 4.9	64.3 [18.8] 36.9 [10.8] 4.8	62.8 [18.4] 34.7 [10.2] 4.8	60.3 [18.5] 45.6 [13.4] 5.0	60.7 [17.8] 41.7 [12.2] 4.9	59.4 [17.4] 39.3 [11.5] 4.8	59.5 [17.4] 51.0 [14.9] 4.9	57.3 [16.8] 46.6 [13.7] 4.8	56.0 [16.4] 43.9 [12.9] 4.8
	95°F [35°C]	Total BTUH [kW] Sens BTUH [kW] Power	64.6 [18.9] 39.2 [11.5] 5.2	62.2 [18.2] 35.7 [10.5] 5.1	60.8 [17.8] 33.7 [9.9] 5.0	60.9 [17.8] 44.4 [13.0] 5.2	58.7 [17.2] 40.5 [11.9] 5.1	57.4 [16.8] 38.2 [11.2] 5.0	57.4 [16.8] 49.8 [14.6] 5.2	55.3 [16.2] 45.4 [13.3] 5.1	54.1 [15.9] 42.8 [12.5] 5.0
	100°F [37.8°C]	Total BTUH [kW] Sens BTUH [kW] Power	62.3 [18.3] 37.8 [11.1] 5.4	60.1 [17.6] 34.5 [10.1] 5.3	58.7 [17.2] 32.5 [9.5] 5.2	58.7 [17.2] 43.0 [12.6] 5.4	56.6 [16.6] 39.3 [11.5] 5.3	55.3 [16.2] 37.0 [10.8] 5.3	55.1 [16.1] 48.4 [14.2] 5.4	53.1 [15.6] 44.2 [13.0] 5.3	52.0 [15.2] 41.6 [12.2] 5.2
	105°F [40.6°C]	Total BTUH [kW] Sens BTUH [kW] Power	60.0 [17.6] 36.2 [10.6] 5.6	57.8 [16.9] 33.1 [9.7] 5.5	56.5 [16.6] 31.2 [9.1] 5.5	56.3 [16.5] 41.5 [12.2] 5.7	54.3 [15.9] 37.9 [11.1] 5.6	53.1 [15.6] 35.7 [10.5] 5.5	52.8 [15.5] 46.9 [13.7] 5.6	50.9 [14.9] 42.8 [12.5] 5.5	49.7 [14.6] 40.3 [11.8] 5.5
	110°F [43.3°C]	Total BTUH [kW] Sens BTUH [kW] Power	57.5 [16.9] 34.6 [10.1] 5.9	55.4 [16.2] 31.5 [9.2] 5.8	54.2 [15.9] 29.7 [8.7] 5.7	53.8 [15.8] 39.8 [11.7] 5.9	51.9 [15.2] 36.3 [10.6] 5.8	50.7 [14.9] 34.2 [10.0] 5.7	50.3 [14.7] 45.2 [13.2] 5.9	48.4 [14.2] 41.2 [12.1] 5.8	47.4 [13.9] 38.9 [11.4] 5.7
	115°F [46.1°C]	Total BTUH [kW] Sens BTUH [kW] Power	54.8 [16.1] 32.7 [9.6] 6.1	52.8 [15.5] 29.9 [8.8] 6.0	51.7 [15.2] 28.2 [8.3] 5.9	51.2 [15.0] 38.0 [11.1] 6.1	49.3 [14.4] 34.7 [10.2] 6.0	48.2 [14.1] 32.7 [9.6] 6.0	47.6 [14.0] 43.4 [12.7] 6.1	45.9 [13.5] 39.6 [11.6] 6.0	44.9 [13.2] 37.3 [10.9] 5.9
	120°F [48.9°C]	Total BTUH [kW] Sens BTUH [kW] Power	52.0 [15.2] 30.8 [9.0] 6.3	50.2 [14.7] 28.1 [8.2] 6.2	49.0 [14.4] 26.5 [7.8] 6.2	48.4 [14.2] 36.0 [10.6] 6.4	46.6 [13.7] 32.9 [9.6] 6.3	45.6 [13.4] 31.0 [9.1] 6.2	44.8 [13.1] 41.4 [12.1] 6.3	43.2 [12.7] 37.8 [11.1] 6.2	42.2 [12.4] 35.6 [10.4] 6.2
125°F [51.7°C]	Total BTUH [kW] Sens BTUH [kW] Power	49.1 [14.4] 28.6 [8.4] 6.6	47.3 [13.9] 26.1 [7.6] 6.5	46.3 [13.6] 24.6 [7.2] 6.4	45.4 [13.3] 33.9 [9.9] 6.6	43.8 [12.8] 30.9 [9.1] 6.5	42.8 [12.5] 29.2 [8.6] 6.4	41.9 [12.3] 39.3 [11.5] 6.6	40.4 [11.8] 35.8 [10.5] 6.5	39.5 [11.6] 33.8 [9.9] 6.4	

DR —Depression ratio
dbE —Entering air dry bulb
wbE—Entering air wet bulb

Total —Total capacity x 1000 BTUH
Sens —Sensible capacity x 1000 BTUH
Power —KW input

NOTES: ① When the entering air dry bulb is other than 80°F [27°C], adjust the sensible capacity from the table by adding [1.10 x CFM x (1 – DR) x (dbE – 80)].

[] Designates Metric Conversions

COOLING PERFORMANCE DATA—RGECYB072

RGECYB072 - ENTERING INDOOR AIR @ 80°F [26.7°C] dbE ①											
wbE		71°F [21.7°C]			67°F [19.4°C]			63°F [17.2°C]			
CFM [L/s]		2525 [1192]	2400 [1133]	1825 [861]	2525 [1192]	2400 [1133]	1825 [861]	2525 [1192]	2400 [1133]	1825 [861]	
DR ①		.05	.09	.12	.05	.09	.12	.05	.09	.12	
O U T D O O R D R Y B U L B T E M P E R A T U R E	75°F [23.9°C]	Total BTUH [kW]	79.7 [23.4]	78.9 [23.1]	75.5 [22.1]	73.8 [21.6]	73.1 [21.4]	70.0 [20.5]	68.0 [19.9]	67.4 [19.8]	64.4 [18.9]
		Sens BTUH [kW]	44.6 [13.1]	43.5 [12.7]	38.6 [11.3]	49.7 [14.6]	48.5 [14.2]	43.1 [12.6]	54.9 [16.1]	53.6 [15.7]	47.6 [14.0]
		Power	4.8	4.8	4.7	4.7	4.7	4.6	4.9	4.8	4.7
	80°F [26.7°C]	Total BTUH [kW]	78.2 [22.9]	77.4 [22.7]	74.1 [21.7]	72.3 [21.2]	71.6 [21.0]	68.5 [20.1]	66.5 [19.5]	65.9 [19.3]	63.0 [18.5]
		Sens BTUH [kW]	44.4 [13.0]	43.4 [12.7]	38.5 [11.3]	49.6 [14.5]	48.4 [14.2]	43.0 [12.6]	54.7 [16.0]	53.4 [15.7]	47.5 [13.9]
		Power	5.2	5.1	5	5.1	5.0	4.9	5.2	5.2	5.1
	85°F [29.4°C]	Total BTUH [kW]	76.6 [22.5]	75.9 [22.2]	72.6 [21.3]	70.8 [20.8]	70.1 [20.5]	67.1 [19.7]	65.0 [19.1]	64.4 [18.9]	61.6 [18.1]
		Sens BTUH [kW]	44.3 [13.0]	43.2 [12.7]	38.4 [11.3]	49.4 [14.5]	48.3 [14.2]	42.9 [12.6]	54.6 [16.0]	53.3 [15.6]	47.4 [13.9]
		Power	5.5	5.5	5.4	5.4	5.4	5.2	5.5	5.5	5.4
	90°F [32.2°C]	Total BTUH [kW]	75.1 [22.0]	74.4 [21.8]	71.2 [20.9]	69.3 [20.3]	68.6 [20.1]	65.7 [19.3]	63.5 [18.6]	62.9 [18.4]	60.1 [17.6]
		Sens BTUH [kW]	44.2 [13.0]	43.1 [12.6]	38.3 [11.2]	49.3 [14.4]	48.1 [14.1]	42.8 [12.5]	54.5 [16.0]	53.2 [15.6]	47.2 [13.8]
		Power	5.8	5.8	5.7	5.7	5.7	5.6	5.8	5.8	5.7
95°F [35°C]	Total BTUH [kW]	73.6 [21.6]	72.9 [21.4]	69.8 [20.5]	67.8 [19.9]	67.1 [19.7]	64.2 [18.8]	61.9 [18.1]	61.4 [18.0]	58.7 [17.2]	
	Sens BTUH [kW]	44.0 [12.9]	43.0 [12.6]	38.2 [11.2]	49.2 [14.4]	48.0 [14.1]	42.6 [12.5]	54.3 [15.9]	53.0 [15.5]	47.1 [13.8]	
	Power	6.1	6.1	6.0	6.0	6.0	5.9	6.2	6.1	6.0	
100°F [37.8°C]	Total BTUH [kW]	72.1 [21.1]	71.4 [20.9]	68.3 [20.0]	66.3 [19.4]	65.6 [19.2]	62.8 [18.4]	60.4 [17.7]	59.9 [17.6]	57.3 [16.8]	
	Sens BTUH [kW]	43.9 [12.9]	42.8 [12.5]	38.0 [11.1]	49.0 [14.4]	47.9 [14.0]	42.5 [12.5]	54.2 [15.9]	52.9 [15.5]	47.0 [13.8]	
	Power	6.5	6.4	6.3	6.4	6.3	6.2	6.5	6.4	6.3	
105°F [40.6°C]	Total BTUH [kW]	70.6 [20.7]	69.9 [20.5]	66.9 [19.6]	64.8 [19.0]	64.1 [18.8]	61.4 [18.0]	58.9 [17.3]	58.4 [17.1]	55.8 [16.4]	
	Sens BTUH [kW]	43.7 [12.8]	42.7 [12.5]	37.9 [11.1]	48.9 [14.3]	47.7 [14.0]	42.4 [12.4]	54.0 [15.8]	52.8 [15.5]	46.9 [13.7]	
	Power	6.8	6.7	6.6	6.7	6.6	6.5	6.8	6.8	6.6	
110°F [43.3°C]	Total BTUH [kW]	69.1 [20.3]	68.4 [20.0]	65.4 [19.2]	63.2 [18.5]	62.6 [18.3]	59.9 [17.6]	57.4 [16.8]	56.9 [16.7]	54.4 [15.9]	
	Sens BTUH [kW]	43.6 [12.8]	42.6 [12.5]	37.8 [11.1]	48.7 [14.3]	47.6 [14.0]	42.3 [12.4]	53.9 [15.8]	52.6 [15.4]	46.7 [13.7]	
	Power	7.1	7.1	6.9	7.0	7.0	6.8	7.1	7.1	6.9	
115°F [46.1°C]	Total BTUH [kW]	67.6 [19.8]	66.9 [19.6]	64.0 [18.8]	61.7 [18.1]	61.1 [17.9]	58.5 [17.1]	55.9 [16.4]	55.4 [16.2]	53 [15.5]	
	Sens BTUH [kW]	43.4 [12.7]	42.4 [12.4]	37.7 [11.0]	48.6 [14.2]	47.5 [13.9]	42.1 [12.3]	53.8 [15.8]	52.5 [15.4]	46.6 [13.7]	
	Power	7.4	7.4	7.2	7.3	7.3	7.1	7.4	7.4	7.2	
120°F [48.9°C]	Total BTUH [kW]	66.0 [19.3]	65.4 [19.2]	62.6 [18.3]	60.2 [17.6]	59.6 [17.5]	57.0 [16.7]	54.4 [15.9]	53.9 [15.8]	51.5 [15.1]	
	Sens BTUH [kW]	43.3 [12.7]	42.3 [12.4]	37.6 [11.0]	48.5 [14.2]	47.3 [13.9]	42.0 [12.3]	53.6 [15.7]	52.4 [15.4]	46.5 [13.6]	
	Power	7.7	7.7	7.5	7.6	7.6	7.4	7.8	7.7	7.6	
125°F [51.7°C]	Total BTUH [kW]	64.5 [18.9]	63.9 [18.7]	61.1 [17.9]	58.7 [17.2]	58.1 [17.0]	55.6 [16.3]	52.9 [15.5]	52.4 [15.4]	50.1 [14.7]	
	Sens BTUH [kW]	43.2 [12.7]	42.1 [12.3]	37.4 [11.0]	48.3 [14.2]	47.2 [13.8]	41.9 [12.3]	52.9 [15.5]	52.2 [15.3]	46.4 [13.6]	
	Power	8.1	8.0	7.9	8.0	7.9	7.8	8.1	8.0	7.9	

DR —Depression ratio
dbE —Entering air dry bulb
wbE—Entering air wet bulb

Total —Total capacity x 1000 BTUH
Sens —Sensible capacity x 1000 BTUH
Power —KW input

NOTES: ① When the entering air dry bulb is other than 80°F [27°C], adjust the sensible capacity from the table by adding $[1.10 \times \text{CFM} \times (1 - \text{DR}) \times (\text{dbE} - 80)]$.

[] Designates Metric Conversions

GROSS SYSTEMS PERFORMANCE DATA (HIGH HUMIDIDRY MODE)— RGECEYB036

ENTERING INDOOR AIR @75°F [23.9°C] dbE ①											
wbE		65.3°F [18.5°C]			64°F [17.8°C]			62.5°F [16.9°C]			
CFM [L/s]		1350 [637]	1168 [551]	1050 [496]	1350 [637]	1168 [551]	1050 [496]	1350 [637]	1168 [551]	1050 [496]	
OUTDOOR DRY BULB TEMPERATURE °F [°C]	60°F [15.6°C]	Total BTUH [kW]	18.7 [5.5]	18.1 [5.3]	17.8 [5.2]	18.4 [5.4]	17.9 [5.3]	17.6 [5.2]	17.3 [5.1]	16.8 [4.9]	16.5 [4.8]
		Sens BTUH [kW]	2.8 [0.8]	2.6 [0.8]	2.5 [0.7]	4.7 [1.4]	4.4 [1.3]	4.2 [1.2]	5.9 [1.7]	5.5 [1.6]	5.3 [1.5]
		Power	2.0	2.0	2.0	2.0	2.0	2.0	2.1	2.0	2.0
	70°F [21.1°C]	Total BTUH [kW]	16.9 [5.0]	16.5 [4.8]	16.2 [4.7]	16.7 [4.9]	16.3 [4.8]	16.0 [4.7]	15.6 [4.6]	15.2 [4.4]	14.9 [4.4]
		Sens BTUH [kW]	1.8 [0.5]	1.7 [0.5]	1.6 [0.5]	3.7 [1.1]	3.5 [1.0]	3.3 [1.0]	4.9 [1.4]	4.6 [1.3]	4.4 [1.3]
		Power	2.1	2.0	2.0	2.1	2.0	2.0	2.1	2.1	2.0
	80°F [26.7°C]	Total BTUH [kW]	15.0 [4.4]	14.6 [4.3]	14.3 [4.2]	14.8 [4.3]	14.4 [4.2]	14.1 [4.1]	13.7 [4.0]	13.3 [3.9]	13.0 [3.8]
		Sens BTUH [kW]	0.4 [0.1]	0.4 [0.1]	0.4 [0.1]	2.4 [0.7]	2.2 [0.7]	2.1 [0.6]	3.6 [1.1]	3.3 [1.0]	3.2 [0.9]
		Power	2.2	2.1	2.1	2.2	2.1	2.1	2.2	2.2	2.1
	90°F [32.2°C]	Total BTUH [kW]	12.8 [3.8]	12.5 [3.7]	12.3 [3.6]	12.6 [3.7]	12.3 [3.6]	12.0 [3.5]	11.5 [3.4]	11.2 [3.3]	11.0 [3.2]
		Sens BTUH [kW]	-1.2 [-0.4]	-1.2 [-0.3]	-1.1 [-0.3]	0.7 [0.2]	0.7 [0.2]	0.6 [0.2]	1.9 [0.6]	1.8 [0.5]	1.7 [0.5]
		Power	2.3	2.3	2.3	2.3	2.3	2.3	2.3	2.3	2.3
	100°F [37.8°C]	Total BTUH [kW]	10.4 [3.1]	10.1 [3.0]	10.0 [2.9]	10.2 [3.0]	9.9 [2.9]	9.8 [2.9]	9.1 [2.7]	8.8 [2.6]	8.7 [2.5]
		Sens BTUH [kW]	-3.2 [-0.9]	-3.0 [-0.9]	-2.9 [-0.8]	-1.3 [-0.4]	-1.2 [-0.4]	-1.1 [-0.3]	-0.1 [0.0]	-0.1 [0.0]	-0.1 [0.0]
		Power	2.5	2.5	2.5	2.5	2.5	2.5	2.5	2.5	2.5
	110°F [43.3°C]	Total BTUH [kW]	7.8 [2.3]	7.6 [2.2]	7.4 [2.2]	7.6 [2.2]	7.4 [2.2]	7.2 [2.1]	6.5 [1.9]	6.3 [1.8]	6.2 [1.8]
		Sens BTUH [kW]	-5.6 [-1.6]	-5.2 [-1.5]	-5.0 [-1.5]	-3.6 [-1.1]	-3.4 [-1.0]	-3.2 [-0.9]	-2.4 [-0.7]	-2.3 [-0.7]	-2.1 [-0.6]
		Power	2.8	2.7	2.7	2.8	2.7	2.7	2.8	2.8	2.7
	120°F [48.9°C]	Total BTUH [kW]	4.9 [1.4]	4.8 [1.4]	4.7 [1.4]	4.7 [1.4]	4.6 [1.3]	4.5 [1.3]	3.6 [1.1]	3.5 [1.0]	3.4 [1.0]
		Sens BTUH [kW]	-8.2 [-2.4]	-7.7 [-2.3]	-7.3 [-2.1]	-6.3 [-1.8]	-5.9 [-1.7]	-5.6 [-1.6]	-5.1 [-1.5]	-4.7 [-1.4]	-4.5 [-1.3]
		Power	3.1	3.1	3.0	3.1	3.0	3.0	3.1	3.1	3.0

DR —Depression ratio
dbE —Entering air dry bulb
wbE—Entering air wet bulb

Total —Total capacity x 1000 BTUH
Sens —Sensible capacity x 1000 BTUH
Power —KW input

NOTES: ① When the entering air dry bulb is other than 75°F [23.9°C], adjust the sensible capacity from the table by adding [1.10 x CFM x (1 – DR) x (dbE – 80)].

[] Designates Metric Conversions

GROSS SYSTEMS PERFORMANCE DATA (HIGH HUMIDIDRY MODE)— RGECYB048

		ENTERING INDOOR AIR @ 75°F [23.9°C] dbE ①									
		65.3°F [18.5°C]			64°F [17.8°C]			62.5°F [16.9°C]			
wbE		CFM [L/s]			1800 [850]	1519 [717]	1400 [661]	1800 [850]	1519 [717]	1400 [661]	
O U T D O O R D R Y B U L B T E M P E R A T U R E ° F [° C]	60°F [15.6°C]	Total BTUH [kW]	25.5 [7.5]	24.7 [7.2]	24.3 [7.1]	24.3 [7.1]	23.5 [6.9]	23.2 [6.8]	22.6 [6.6]	21.8 [6.4]	21.5 [6.3]
		Sens BTUH [kW]	2.6 [0.8]	2.4 [0.7]	2.3 [0.7]	5.2 [1.5]	4.8 [1.4]	4.6 [1.4]	6.7 [2.0]	6.1 [1.8]	5.9 [1.7]
		Power	2.5	2.4	2.4	2.5	2.5	2.5	2.4	2.4	2.4
	70°F [21.1°C]	Total BTUH [kW]	24.1 [7.1]	23.3 [6.8]	23.0 [6.7]	22.9 [6.7]	22.2 [6.5]	21.8 [6.4]	21.2 [6.2]	20.5 [6.0]	20.2 [5.9]
		Sens BTUH [kW]	1.9 [0.6]	1.8 [0.5]	1.7 [0.5]	4.5 [1.3]	4.2 [1.2]	4.0 [1.2]	6.0 [1.8]	5.5 [1.6]	5.3 [1.6]
		Power	2.6	2.5	2.5	2.7	2.6	2.6	2.6	2.5	2.5
	80°F [26.7°C]	Total BTUH [kW]	22.1 [6.5]	21.4 [6.3]	21.1 [6.2]	20.9 [6.1]	20.2 [5.9]	20.0 [5.8]	19.2 [5.6]	18.6 [5.4]	18.3 [5.4]
		Sens BTUH [kW]	0.4 [0.1]	0.4 [0.1]	0.4 [0.1]	3.0 [0.9]	2.8 [0.8]	2.7 [0.8]	4.5 [1.3]	4.1 [1.2]	4.0 [1.2]
		Power	2.8	2.7	2.7	2.8	2.8	2.8	2.7	2.7	2.7
	90°F [32.2°C]	Total BTUH [kW]	19.5 [5.7]	18.9 [5.5]	18.6 [5.5]	18.3 [5.4]	17.7 [5.2]	17.5 [5.1]	16.6 [4.9]	16.1 [4.7]	15.8 [4.6]
		Sens BTUH [kW]	-1.9 [-0.5]	-1.7 [-0.5]	-1.7 [-0.5]	0.7 [0.2]	0.7 [0.2]	0.6 [0.2]	2.2 [0.6]	2.0 [0.6]	1.9 [0.6]
		Power	3.0	2.9	2.9	3.0	3.0	3.0	3.0	2.9	2.9
100°F [37.8°C]	Total BTUH [kW]	16.4 [4.8]	15.8 [4.6]	15.6 [4.6]	15.2 [4.4]	14.7 [4.3]	14.5 [4.2]	13.4 [3.9]	13.0 [3.8]	12.8 [3.8]	
	Sens BTUH [kW]	-5.0 [-1.5]	-4.6 [-1.4]	-4.4 [-1.3]	-2.4 [-0.7]	-2.2 [-0.7]	-2.1 [-0.6]	-0.9 [-0.3]	-0.9 [-0.3]	-0.8 [-0.2]	
	Power	3.3	3.2	3.2	3.3	3.3	3.3	3.2	3.2	3.2	
110°F [43.3°C]	Total BTUH [kW]	12.6 [3.7]	12.2 [3.6]	12.0 [3.5]	11.4 [3.3]	11.0 [3.2]	10.9 [3.2]	9.7 [2.8]	9.4 [2.7]	9.2 [2.7]	
	Sens BTUH [kW]	-9.0 [-2.6]	-8.3 [-2.4]	-8 [-2.3]	-6.4 [-1.9]	-5.9 [-1.7]	-5.6 [-1.7]	-4.9 [-1.4]	-4.5 [-1.3]	-4.3 [-1.3]	
	Power	3.6	3.6	3.5	3.7	3.6	3.6	3.6	3.5	3.5	
120°F [48.9°C]	Total BTUH [kW]	8.2 [2.4]	8.0 [2.3]	7.9 [2.3]	7.1 [2.1]	6.8 [2.0]	6.7 [2.0]	5.3 [1.6]	5.2 [1.5]	5.1 [1.5]	
	Sens BTUH [kW]	-13.7 [-4.0]	-12.7 [-3.7]	-12.2 [-3.6]	-11.1 [-3.3]	-10.3 [-3.0]	-9.9 [-2.9]	-9.7 [-2.8]	-8.9 [-2.6]	-8.6 [-2.5]	
	Power	4.0	4.0	3.9	4.1	4.0	4.0	4.0	3.9	3.9	

DR —Depression ratio
dbE—Entering air dry bulb
wbE—Entering air wet bulb

Total —Total capacity x 1000 BTUH
Sens —Sensible capacity x 1000 BTUH
Power —KW input

NOTES: ① When the entering air dry bulb is other than 75°F [23.9°C], adjust the sensible capacity from the table by adding [1.10 x CFM x (1 – DR) x (dbE – 80)].

[] Designates Metric Conversions

GROSS SYSTEMS PERFORMANCE DATA (HIGH HUMIDIDRY MODE)— RGECEYB060

ENTERING INDOOR AIR @ 75°F [23.9°C] dbE ①											
wbE		65.3°F [18.5°C]			64°F [17.8°C]			62.5°F [16.9°C]			
CFM [L/s]		2250 [1062]	1825 [861]	1750 [826]	2250 [1062]	1825 [861]	1750 [826]	2250 [1062]	1825 [861]	1750 [826]	
OUTDOOR DRY BULB TEMPERATURE °F [°C]	60°F [15.6°C]	Total BTUH [kW]	29.1 [8.5]	27.9 [8.2]	27.7 [8.1]	28.5 [8.3]	27.3 [8.0]	27.1 [7.9]	26.6 [7.8]	25.5 [7.5]	25.3 [7.4]
		Sens BTUH [kW]	1.9 [0.5]	1.7 [0.5]	1.7 [0.5]	5.1 [1.5]	4.6 [1.3]	4.5 [1.3]	7.9 [2.3]	7.1 [2.1]	7.0 [2.1]
		Power	3.5	3.5	3.5	3.5	3.5	3.4	3.5	3.5	3.5
	70°F [21.1°C]	Total BTUH [kW]	27.5 [8.0]	26.3 [7.7]	26.2 [7.7]	26.8 [7.9]	25.7 [7.5]	25.5 [7.5]	24.9 [7.3]	23.9 [7.0]	23.7 [7.0]
		Sens BTUH [kW]	0.6 [0.2]	0.6 [0.2]	0.6 [0.2]	3.8 [1.1]	3.4 [1.0]	3.4 [1.0]	6.7 [2.0]	6.0 [1.8]	5.9 [1.7]
		Power	3.6	3.6	3.6	3.6	3.6	3.5	3.6	3.6	3.6
	80°F [26.7°C]	Total BTUH [kW]	25.2 [7.4]	24.2 [7.1]	24.0 [7.0]	24.5 [7.2]	23.5 [6.9]	23.4 [6.8]	22.6 [6.6]	21.7 v[6.4]	21.6 v[6.3]
Sens BTUH [kW]		-1.2 [-0.4]	-1.1 [-0.3]	-1.1 [-0.3]	2.0 [0.6]	1.8 [0.5]	1.8 [0.5]	4.8 [1.4]	4.4 [1.3]	4.3 [1.3]	
Power		3.8	3.8	3.7	3.8	3.7	3.7	3.8	3.8	3.7	
90°F [32.2°C]	Total BTUH [kW]	22.3 [6.5]	21.4 [6.3]	21.2 [6.2]	21.6 [6.3]	20.8 [6.1]	20.6 [6.0]	19.7 [5.8]	18.9 [5.5]	18.8 [5.5]	
	Sens BTUH [kW]	-3.6 [-1.1]	-3.3 [-1.0]	-3.2 [-0.9]	-0.4 [-0.1]	-0.4 [-0.1]	-0.4 [-0.1]	2.4 [0.7]	2.2 [0.6]	2.1 [0.6]	
	Power	4.1	4.0	4.0	4.1	4.0	4.0	4.1	4.0	4.0	
100°F [37.8°C]	Total BTUH [kW]	18.7 [5.5]	18.0 [5.3]	17.8 [5.2]	18.1 [5.3]	17.4 [5.1]	17.2 [5.1]	16.2 [4.7]	15.5 [4.6]	15.4 [4.5]	
	Sens BTUH [kW]	-6.7 [-1.9]	-6.0 [-1.8]	-5.9 [-1.7]	-3.5 [-1.0]	-3.1 [-0.9]	-3.1 [-0.9]	-0.6 [-0.2]	-0.6 [-0.2]	-0.5 [-0.2]	
	Power	4.5	4.4	4.4	4.5	4.4	4.4	4.5	4.4	4.4	
110°F [43.3°C]	Total BTUH [kW]	14.6 [4.3]	14.0 [4.1]	13.9 [4.1]	13.9 [4.1]	13.4 [3.9]	13.3 [3.9]	12.0 [3.5]	11.6 [3.4]	11.5 [3.4]	
	Sens BTUH [kW]	-10.3 [-3.0]	-9.3 [-2.7]	-9.1 [-2.7]	-7.1 [-2.1]	-6.4 [-1.9]	-6.2 [-1.8]	-4.2 [-1.2]	-3.8 [-1.1]	-3.7 [-1.1]	
	Power	5.0	4.9	4.9	5.0	4.9	4.8	5.0	4.9	4.9	
120°F [48.9°C]	Total BTUH [kW]	9.8 [2.9]	9.4 [2.8]	9.3 [2.7]	9.2 [2.7]	8.8 [2.6]	8.7 [2.6]	7.3 [2.1]	7.0 [2.0]	6.9 [2.0]	
	Sens BTUH [kW]	-14.5 [-4.2]	-13.0 [-3.8]	-12.8 [-3.7]	-11.3 [-3.3]	-10.2 [-3]	-10.0 [-2.9]	-8.4 [-2.5]	-7.6 [-2.2]	-7.4 [-2.2]	
	Power	5.6	5.4	5.4	5.5	5.4	5.4	5.5	5.4	5.4	

DR —Depression ratio
dbE —Entering air dry bulb
wbE—Entering air wet bulb

Total —Total capacity x 1000 BTUH
Sens —Sensible capacity x 1000 BTUH
Power —KW input

NOTES: ① When the entering air dry bulb is other than 75°F [23.9°C], adjust the sensible capacity from the table by adding [1.10 x CFM x (1 – DR) x (dbE – 80)].

[] Designates Metric Conversions

GROSS SYSTEMS PERFORMANCE DATA (LOW HUMIDIDRY MODE)— RGECYB072

		ENTERING INDOOR AIR @75°F [23.9°C] dbE ①									
wbE		65.3°F [18.5°C]			64°F [17.8°C]			62.5°F [16.9°C]			
CFM [L/s]		1710 [807]	1523 [719]	1330 [628]	1710 [807]	1523 [719]	1330 [628]	1710 [807]	1523 [719]	1330 [628]	
OUTDOOR DRY BULB TEMPERATURE °F [°C]	60°F [15.6°C]	Total BTUH [kW] Sens BTUH [kW] Power	35.8 [10.5] 12.8 [3.7] 2.3	35.0 [10.3] 12.1 [3.5] 2.2	34.2 [10.0] 11.4 [3.3] 2.2	32.5 [9.5] 12.6 [3.7] 2.3	31.8 [9.3] 12.0 [3.5] 2.3	31.0 [9.1] 11.3 [3.3] 2.3	31.4 [9.2] 16.2 [4.8] 2.2	30.7 [9.0] 15.3 [4.5] 2.2	30 [8.8] 14.4 [4.2] 2.2
	65°F [18.3°C]	Total BTUH [kW] Sens BTUH [kW] Power	34.3 [10.1] 11.5 [3.4] 2.4	33.6 [9.8] 10.8 [3.2] 2.4	32.8 [9.6] 10.2 [3.0] 2.4	31.0 [9.1] 11.3 [3.3] 2.5	30.3 [8.9] 10.7 [3.1] 2.4	29.6 [8.7] 10.1 [3.0] 2.4	30.0 [8.8] 14.9 [4.4] 2.4	29.3 [8.6] 14.1 [4.1] 2.3	28.6 [8.4] 13.3 [3.9] 2.3
	70°F [21.1°C]	Total BTUH [kW] Sens BTUH [kW] Power	32.6 [9.6] 10.0 [2.9] 2.6	31.9 [9.4] 9.4 [2.8] 2.6	31.2 [9.1] 8.9 [2.6] 2.5	29.4 [8.6] 9.8 [2.9] 2.6	28.7 [8.4] 9.3 [2.7] 2.6	28.1 [8.2] 8.8 [2.6] 2.6	28.3 [8.3] 13.4 [3.9] 2.5	27.7 [8.1] 12.7 [3.7] 2.5	27.0 [7.9] 11.9 [3.5] 2.5
	75°F [23.9°C]	Total BTUH [kW] Sens BTUH [kW] Power	30.8 [9.0] 8.3 [2.4] 2.8	30.1 [8.8] 7.9 [2.3] 2.8	29.4 [8.6] 7.4 [2.2] 2.7	27.5 [8.1] 8.2 [2.4] 2.8	26.9 [7.9] 7.7 [2.3] 2.8	26.3 [7.7] 7.3 [2.1] 2.8	26.4 [7.7] 11.8 [3.4] 2.7	25.8 [7.6] 11.1 [3.3] 2.7	25.2 [7.4] 10.5 [3.1] 2.7
	80°F [26.7°C]	Total BTUH [kW] Sens BTUH [kW] Power	28.7 [8.4] 6.5 [1.9] 3.0	28.1 [8.2] 6.1 [1.8] 2.9	27.4 [8.0] 5.8 [1.7] 2.9	25.4 [7.4] 6.4 [1.9] 3.0	24.8 [7.3] 6.0 [1.8] 3	24.3 [7.1] 5.7 [1.7] 2.9	24.3 [7.1] 10.0 [2.9] 2.9	23.8 [7.0] 9.4 [2.8] 2.9	23.3 [6.8] 8.9 [2.6] 2.9
	85°F [29.4°C]	Total BTUH [kW] Sens BTUH [kW] Power	26.4 [7.7] 4.5 [1.3] 3.2	25.8 [7.6] 4.3 [1.3] 3.1	25.2 [7.4] 4.0 [1.2] 3.1	23.1 [6.8] 4.4 [1.3] 3.2	22.6 [6.6] 4.2 [1.2] 3.2	22.1 [6.5] 3.9 [1.1] 3.1	22.0 [6.5] 8.0 [2.3] 3.1	21.6 [6.3] 7.5 [2.2] 3.1	21.1 [6.2] 7.1 [2.1] 3.1
	90°F [32.2°C]	Total BTUH [kW] Sens BTUH [kW] Power	23.9 [7.0] 2.4 [0.7] 3.4	23.4 [6.9] 2.2 [0.7] 3.3	22.8 [6.7] 2.1 [0.6] 3.3	20.6 [6.0] 2.2 [0.7] 3.4	20.2 [5.9] 2.1 [0.6] 3.4	19.7 [5.8] 2.0 [0.6] 3.3	19.6 [5.7] 5.8 [1.7] 3.3	19.1 [5.6] 5.5 [1.6] 3.3	18.7 [5.5] 5.2 [1.5] 3.3

DR —Depression ratio
dbE —Entering air dry bulb
wbE —Entering air wet bulb

Total —Total capacity x 1000 BTUH
Sens —Sensible capacity x 1000 BTUH
Power —KW input

NOTES: ① When the entering air dry bulb is other than 75°F [23.9°C], adjust the sensible capacity from the table by adding [1.10 x CFM x (1 - DR) x (dbE - 80)].

[] Designates Metric Conversions

**GROSS SYSTEMS PERFORMANCE DATA (HIGH HUMIDIDRY MODE)—
RGECEYB072**

		ENTERING INDOOR AIR @ 75°F [23.9°C] dbE ①									
wbE		65.3°F [18.5°C]			64°F [17.8°C]			62.5°F [16.9°C]			
CFM [L/s]		2700 [1274]	2404 [1135]	2100 [991]	2700 [1274]	2404 [1135]	2100 [991]	2700 [1274]	2404 [1135]	2100 [991]	
O U T D O O R D R Y B U L B T E M P E R A T U R E ° F [° C]	60°F [15.6°C]	Total BTUH [kW]	44.6 [13.1]	43.6 [12.8]	42.6 [12.5]	43.0 [12.6]	42.1 [12.3]	41.1 [12.1]	39.3 [11.5]	38.4 [11.3]	37.5 [11.0]
		Sens BTUH [kW]	13.3 [3.9]	12.6 [3.7]	11.8 [3.5]	15.5 [4.5]	14.7 [4.3]	13.8 [4.0]	20.2 [5.9]	19.1 [5.6]	18.0 [5.3]
		Power	3.8	3.7	3.7	3.7	3.7	3.6	3.7	3.6	3.6
	70°F [21.1°C]	Total BTUH [kW]	42.4 [12.4]	41.5 [12.2]	40.6 [11.9]	40.9 [12.0]	40.0 [11.7]	39.1 [11.5]	37.1 [10.9]	36.3 [10.6]	35.5 [10.4]
		Sens BTUH [kW]	11.3 [3.3]	10.7 [3.1]	10.1 [3.0]	13.6 [4.0]	12.8 [3.8]	12.1 [3.5]	18.3 [5.4]	17.3 [5.1]	16.3 [4.8]
		Power	3.9	3.9	3.8	3.9	3.8	3.8	3.8	3.8	3.7
	80°F [26.7°C]	Total BTUH [kW]	38.9 [11.4]	38.1 [11.2]	37.2 [10.9]	37.4 [11.0]	36.6 [10.7]	35.7 [10.5]	33.6 [9.9]	32.9 [9.6]	32.1 [9.4]
Sens BTUH [kW]		8.2 [2.4]	7.8 [2.3]	7.3 [2.1]	10.4 [3.1]	9.9 [2.9]	9.3 [2.7]	15.1 [4.4]	14.3 [4.2]	13.5 [4.0]	
Power		4.2	4.1	4.1	4.1	4.1	4.1	4.1	4.0	4.0	
90°F [32.2°C]	Total BTUH [kW]	34.1 [10.0]	33.3 [9.8]	32.6 [9.5]	32.5 [9.5]	31.8 [9.3]	31.1 [9.1]	28.8 [8.4]	28.1 [8.2]	27.5 [8.1]	
	Sens BTUH [kW]	3.9 [1.1]	3.7 [1.1]	3.5 [1.0]	6.1 [1.8]	5.8 [1.7]	5.5 [1.6]	10.8 [3.2]	10.2 [3.0]	9.6 [2.8]	
	Power	4.5	4.5	4.4	4.5	4.5	4.4	4.4	4.4	4.4	
100°F [37.8°C]	Total BTUH [kW]	27.8 [8.2]	27.2 [8.0]	26.6 [7.8]	26.3 [7.7]	25.7 [7.5]	25.1 [7.4]	22.5 [6.6]	22.0 [6.5]	21.5 [6.3]	
	Sens BTUH [kW]	-1.6 [-0.5]	-1.5 [-0.4]	-1.4 [-0.4]	0.6 [0.2]	0.6 [0.2]	0.6 [0.2]	5.3 [1.6]	5.0 [1.5]	4.7 [1.4]	
	Power	5.0	4.9	4.9	5.0	4.9	4.9	4.9	4.9	4.8	
110°F [43.3°C]	Total BTUH [kW]	20.2 [5.9]	19.8 [5.8]	19.3 [5.7]	18.7 [5.5]	18.3 [5.4]	17.9 [5.2]	14.9 [4.4]	14.6 [4.3]	14.2 [4.2]	
	Sens BTUH [kW]	-8.3 [-2.4]	-7.8 [-2.3]	-7.4 [-2.2]	-6.1 [-1.8]	-5.7 [-1.7]	-5.4 [-1.6]	-1.4 [-0.4]	-1.3 [-0.4]	-1.2 [-0.4]	
	Power	5.6	5.5	5.4	5.5	5.5	5.4	5.5	5.4	5.3	
120°F [48.9°C]	Total BTUH [kW]	11.2 [3.3]	11.0 [3.2]	10.7 [3.1]	9.7 [2.8]	9.5 [2.8]	9.3 [2.7]	5.9 [1.7]	5.8 [1.7]	5.7 [1.7]	
	Sens BTUH [kW]	-16.2 [-4.7]	-15.3 [-4.5]	-14.4 [-4.2]	-14.0 [-4.1]	-13.2 [-3.9]	-12.4 [-3.6]	-9.3 [-2.7]	-8.8 [-2.6]	-8.2 [-2.4]	
	Power	6.2	6.1	6.1	6.2	6.1	6.0	6.1	6.0	6.0	

DR —Depression ratio
 dbE —Entering air dry bulb
 wbE —Entering air wet bulb

Total —Total capacity x 1000 BTUH
 Sens —Sensible capacity x 1000 BTUH
 Power —KW input

NOTES: ① When the entering air dry bulb is other than 75°F [23.9°C], adjust the sensible capacity from the table by adding [1.10 x CFM x (1 - DR) x (dbE - 80)].

[] Designates Metric Conversions

3-6T – LOW STATIC – SIDEFLOW (208-230V/575V)

Unit Model (Tonnage)	Manufacturer Recommended Airflow Range (Min/Max) CFM	Motor HP [W]	Motor Speed	CFM/ WATTS	External Static Pressure - Inches W.C. [kPa]							
					0.1 [.02]	0.2 [.05]	0.3 [.07]	0.4 [.10]	0.5 [.12]	0.6 [.15]	0.7 [.17]	0.8 [.20]
RGECYB036 (3T)	1050/1350	3/4 HP [559]	Fan - Tap 1	CFM	1187	981	780	686	562	485	399	321
				WATTS	149	126	111	117	123	128	133	137
		3/4 HP [559]	Tap 2	CFM	1504	1435	1370	1304	1239	1176	1108	1047
				WATTS	269	281	293	302	314	326	335	344
		3/4 HP [559]	Tap 3	CFM	1731	1668	1610	1554	1498	1444	1386	1336
				WATTS	394	408	421	432	447	459	472	485
		3/4 HP [559]	Cooling - Tap 4 *	CFM	1504	1435	1370	1304	1239	1176	1108	1047
				WATTS	269	281	293	302	314	326	335	344
		3/4 HP [559]	High Speed - Tap 5	CFM	1642	1575	1517	1457	1400	1341	1287	1231
				WATTS	340	353	366	377	390	402	413	425
RGECYB048 (4T)	1400/1800	3/4 HP [559]	Fan - Tap 1	CFM	1204	1021	893	813	729	618	519	451
				WATTS	157	136	133	140	147	157	163	169
		3/4 HP [559]	Tap 2	CFM	1702	1639	1579	1516	1459	1400	1345	1297
				WATTS	364	376	389	402	413	425	436	447
		3/4 HP [559]	Tap 3	CFM	1765	1700	1646	1591	1529	1472	1419	1366
				WATTS	402	415	427	439	452	464	474	488
		3/4 HP [559]	Cooling - Tap 4 *	CFM	1830	1786	1731	1677	1623	1573	1511	1465
				WATTS	449	460	472	487	500	515	529	540
		3/4 HP [559]	High Speed - Tap 5	CFM	1942	1886	1838	1774	1722	1670	1618	1575
				WATTS	524	540	552	568	578	592	606	619
RGECYB060 (5T)	1750/2250	1 HP [745]	Fan - Tap 1	CFM	1247	1055	973	890	817	733	620	552
				WATTS	158	137	145	151	160	168	172	180
		1 HP [745]	Tap 2	CFM	1650	1590	1527	1467	1415	1357	1307	1248
				WATTS	318	331	347	351	366	378	388	402
		1 HP [745]	Tap 3	CFM	1804	1753	1694	1646	1598	1539	1482	1432
				WATTS	416	427	442	453	466	479	490	504
		1 HP [745]	Cooling - Tap 4 *	CFM	2087	2040	1991	1944	1903	1864	1824	1771
				WATTS	658	673	688	702	718	733	748	742
		1 HP [745]	High Speed - Tap 5	CFM	2236	2179	2142	2093	2049	1997	1953	1896
				WATTS	759	777	789	808	823	844	854	851
RGECYB072 (6T)	2100/2700	1.2 HP [895]	Fan/Low Heat - Tap 1	CFM	1384	1319	1249	1188	1127	1066	1006	947
				WATTS	192	204	215	225	240	245	255	265
		1.2 HP [895]	High Heat - Tap 2	CFM	1874	1833	1778	1730	1680	1630	1584	1539
				WATTS	421	435	450	466	480	495	510	525
		1.2 HP [895]	Low Cool - Tap 3	CFM	1546	1488	1427	1372	1316	1261	1203	1149
				WATTS	258	270	282	298	310	318	330	338
		1.2 HP [895]	High Cool - Tap 4	CFM	2435	2402	2376	2328	2287	2256	2220	2197
				WATTS	986	1010	1030	1058	1091	1125	1144	1166
		1.2 HP [895]	High Speed - Tap 5	CFM	2515	2476	2436	2415	2383	2339	2282	2221
				WATTS	1070	1103	1139	1163	1187	1215	1219	1221

NOTES: *Tap 4 - Factory Cooling Tap
 Pressure drops across the 3-5T CFM range (1050 - 2250): Wet coil: ~0.09 Inches W.C.
 Downflow: ~0.1 Inches W.C. Reheat coil: ~0.09 Inches W.C.

[] Designates Metric Conversions

3-6T – HIGH STATIC – SIDEFLOW (208-230V/575V)

Unit Model (Tonnage)	Manufacturer Recommended Airflow Range (Min/Max) CFM	Motor HP [W]	Motor Speed	CFM/ WATTS	External Static Pressure - Inches W.C. [kPa]							
					0.8 [.2]	0.9 [.22]	1 [.25]	1.1 [.27]	1.2 [.3]	1.3 [.32]	1.4 [.35]	1.5 [.37]
RGECEB036 (3T)	1050/1350	1.5 HP [1119]	Fan - Tap 1	CFM	580	502	431	367	316	257	195	127
				WATTS	210	217	223	228	234	240	246	252
		1.5 HP [1119]	Tap 2	CFM	1105	1047	984	923	863	800	740	684
				WATTS	372	383	393	404	413	421	429	438
		1.5 HP [1119]	Tap 3	CFM	1302	1245	1193	1138	1080	1018	963	906
				WATTS	462	475	486	497	509	520	532	539
		1.5 HP [1119]	Cooling - Tap 4 *	CFM	1068	1008	953	888	824	767	719	670
				WATTS	320	328	337	345	355	363	373	380
		1.5 HP [1119]	High Speed - Tap 5	CFM	1105	1047	984	923	863	800	740	684
				WATTS	372	383	393	404	413	421	429	438
RGECEB048 (4T)	1400/1800	1.5 HP [1119]	Fan - Tap 1	CFM	1055	991	916	847	788	734	671	617
				WATTS	349	357	369	380	389	399	408	414
		1.5 HP [1119]	Tap 2	CFM	1360	1311	1264	1214	1162	1105	1050	992
				WATTS	495	507	517	530	540	554	568	585
		1.5 HP [1119]	Tap 3	CFM	1421	1369	1321	1271	1217	1167	1114	1053
				WATTS	526	539	550	563	575	586	602	616
		1.5 HP [1119]	Cooling - Tap 4 *	CFM	1188	1128	1073	1009	948	883	828	775
				WATTS	406	415	428	439	449	462	471	480
		1.5 HP [1119]	High Speed - Tap 5	CFM	1495	1443	1394	1345	1292	1248	1195	1140
				WATTS	567	581	596	607	620	631	646	658
RGECEB060 (5T)	1750/2250	1.5 HP [1119]	Fan - Tap 1	CFM	1244	1187	1125	1074	1016	956	878	812
				WATTS	431	439	456	461	477	486	492	510
		1.5 HP [1119]	Tap 2	CFM	1244	1187	1125	1074	1016	956	878	812
				WATTS	431	439	456	461	477	486	492	510
		1.5 HP [1119]	Tap 3	CFM	1537	1496	1455	1409	1362	1310	1257	1206
				WATTS	599	613	627	642	653	667	680	696
		1.5 HP [1119]	Cooling - Tap 4 *	CFM	1472	1432	1388	1338	1285	1233	1180	1134
				WATTS	557	570	585	599	610	623	636	649
		1.5 HP [1119]	High Speed - Tap 5	CFM	1686	1642	1605	1564	1523	1479	1428	1380
				WATTS	707	721	736	750	765	781	795	807
RGECEB072 (6T)	2100/2700	1.2 HP [895]	Fan/Low Heat - Tap 1	CFM	1237	1182	1137	1076	996	961	906	853
				WATTS	364	373	386	396	405	409	421	431
		1.2 HP [895]	High Heat - Tap 2	CFM	2043	2004	1953	1917	1879	1828	1783	1750
				WATTS	834	850	861	876	891	906	925	938
		1.2 HP [895]	Low Cool - Tap 3	CFM	1149	1082	1030	969	891	837	781	728
				WATTS	338	345	357	365	374	383	393	403
		1.2 HP [895]	High Cool - Tap 4	CFM	2197	2155	2081	2034	1995	1940	1881	1791
				WATTS	1166	1190	1198	1203	1203	1203	1200	1160
		1.2 HP [895]	High Speed - Tap 5	CFM	2221	2169	2115	2061	1997	1937	1873	1788
				WATTS	1221	1226	1227	1227	1223	1225	1208	1160

NOTES: *Tap 4 - Factory Cooling Tap
 Pressure drops across the 3-5T CFM range (1050 - 2250): Wet coil: ~0.09 Inches W.C.
 Downflow: ~0.1 Inches W.C. Reheat coil: ~0.09 Inches W.C.

[] Designates Metric Conversions

3-6T—LOW STATIC—SIDEFLOW (460V)

Unit Model (Tonnage)	Manufacturer Recommended Airflow Range (Min/Max) CFM	Motor HP [W]	Motor Speed	CFM/ WATTS	External Static Pressure - Inches W.C. [kPa]							
					0.1 [.02]	0.2 [.05]	0.3 [.07]	0.4 [.10]	0.5 [.12]	0.6 [.15]	0.7 [.17]	0.8 [.20]
RGECEB036 (3T)	1050/1350	3/4 HP [559]	Fan - Tap 1	CFM	957	867	777	686	562	477	388	313
				WATTS	94	102	110	117	125	130	135	140
		3/4 HP [559]	Tap 2	CFM	1155	1076	1001	922	843	767	669	597
				WATTS	140	150	159	168	176	184	193	200
		3/4 HP [559]	Tap 3	CFM	1697	1641	1586	1530	1473	1413	1364	1314
				WATTS	365	378	390	404	418	432	444	457
		3/4 HP [559]	Cooling - Tap 4 *	CFM	1499	1436	1370	1309	1253	1190	1128	1073
				WATTS	254	266	279	291	301	313	322	332
		3/4 HP [559]	High Speed - Tap 5	CFM	1612	1551	1493	1435	1373	1316	1261	1205
				WATTS	316	329	341	353	367	379	392	404
RGECEB048 (4T)	1400/1800	3/4 HP [559]	Fan - Tap 1	CFM	1061	965	882	801	707	545	445	359
				WATTS	114	124	132	140	148	154	160	166
		3/4 HP [559]	Tap 2	CFM	1319	1247	1172	1105	1039	962	884	807
				WATTS	189	200	211	221	231	242	250	259
		3/4 HP [559]	Tap 3	CFM	1737	1684	1624	1564	1509	1453	1400	1345
				WATTS	374	391	404	417	430	445	458	471
		3/4 HP [559]	Cooling - Tap 4 *	CFM	1805	1749	1698	1650	1602	1557	1504	1452
				WATTS	420	435	449	461	475	490	504	516
		3/4 HP [559]	High Speed - Tap 5	CFM	1923	1862	1813	1763	1711	1657	1610	1556
				WATTS	485	500	514	532	545	563	576	594
RGECEB060 (5T)	1750/2250	1 HP [745]	Fan - Tap 1	CFM	1107	1017	936	865	793	711	592	527
				WATTS	126	135	143	151	158	166	174	181
		1 HP [745]	Tap 2	CFM	1216	1140	1075	993	922	859	790	706
				WATTS	159	168	177	185	193	202	211	220
		1 HP [745]	Tap 3	CFM	1770	1714	1658	1598	1545	1485	1432	1389
				WATTS	394	407	420	434	447	459	471	482
		1 HP [745]	Cooling - Tap 4 *	CFM	2078	2041	1991	1925	1867	1827	1780	1731
				WATTS	606	620	635	651	667	680	695	709
		1 HP [745]	High Speed - Tap 5	CFM	2192	2151	2105	2056	2005	1961	1923	1874
				WATTS	720	737	752	767	784	801	815	830
RGECEB072 (6T)	2100/2700	1.2 HP [895]	Fan/Low Heat - Tap 1	CFM	1384	1319	1249	1188	1127	1066	1006	947
				WATTS	192	204	215	225	240	245	255	265
		1.2 HP [895]	High Heat - Tap 2	CFM	1863	1821	1765	1717	1650	1617	1571	1526
				WATTS	413	428	442	459	474	488	503	518
		1.2 HP [895]	Low Cool - Tap 3	CFM	1546	1488	1427	1372	1316	1261	1203	1149
				WATTS	258	270	282	298	310	318	330	338
		1.2 HP [895]	High Cool - Tap 4	CFM	2395	2349	2295	2250	2199	2151	2108	2054
				WATTS	928	943	961	976	987	1001	1016	1032
		1.2 HP [895]	High Speed - Tap 5	CFM	2441	2398	2367	2320	2276	2218	2170	2118
				WATTS	989	1008	1035	1046	1055	1075	1089	1094

NOTES: *Tap 4 - Factory Cooling Tap
 Pressure drops across the 3-5T CFM range (1050 - 2250): Wet coil: ~0.09 Inches W.C.
 Downflow: ~0.1 Inches W.C. Reheat coil: ~0.09 Inches W.C.

[] Designates Metric Conversions

3-6T – HIGH STATIC – SIDEFLOW (460V)

Unit Model (Tonnage)	Manufacturer Recommended Airflow Range (Min/Max) CFM	Motor HP [W]	Motor Speed	CFM/ WATTS	External Static Pressure - Inches W.C. [kPa]							
					0.8 [.2]	0.9 [.22]	1 [.25]	1.1 [.27]	1.2 [.3]	1.3 [.32]	1.4 [.35]	1.5 [.37]
RGECEB036 (3T)	1050/1350	1 HP [745]	Fan - Tap 1	CFM	729	644	554	499	438	386	329	278
				WATTS	226	233	240	245	252	257	262	267
		1 HP [745]	Tap 2	CFM	729	644	554	499	438	386	329	278
				WATTS	226	233	240	245	252	257	262	267
		1 HP [745]	Tap 3	CFM	1465	1421	1372	1320	1272	1226	1176	1122
				WATTS	535	547	559	571	583	593	603	615
		1 HP [745]	Cooling - Tap 4 *	CFM	1012	951	873	808	740	679	623	573
				WATTS	313	322	332	340	349	357	363	371
		1 HP [745]	High Speed - Tap 5	CFM	1345	1292	1239	1184	1135	1082	1016	947
				WATTS	460	472	483	493	503	513	525	537
RGECEB048 (4T)	1400/1800	1 HP [745]	Fan - Tap 1	CFM	871	794	722	654	580	526	466	413
				WATTS	267	275	283	290	297	303	310	315
		1 HP [745]	Tap 2	CFM	1344	1292	1239	1192	1138	1084	1007	953
				WATTS	458	470	481	490	500	510	525	534
		1 HP [745]	Tap 3	CFM	1514	1464	1415	1374	1323	1275	1228	1184
				WATTS	561	576	589	600	611	622	633	645
		1 HP [745]	Cooling - Tap 4 *	CFM	1423	1376	1328	1277	1227	1184	1139	1067
				WATTS	509	521	533	544	555	565	576	589
		1 HP [745]	High Speed - Tap 5	CFM	1589	1545	1497	1463	1413	1367	1317	1275
				WATTS	618	633	647	660	672	683	695	705
RGECEB060 (5T)	1750/2250	1.2 HP [895]	Fan - Tap 1	CFM	1091	1034	983	924	865	790	724	666
				WATTS	343	353	359	371	380	387	396	404
		1.2 HP [895]	Tap 2	CFM	1091	1034	983	924	865	790	724	666
				WATTS	343	353	359	371	380	387	396	404
		1.2 HP [895]	Tap 3	CFM	1841	1794	1748	1703	1657	1615	1578	1538
				WATTS	794	809	826	836	847	859	870	878
		1.2 HP [895]	Cooling - Tap 4 *	CFM	1762	1714	1669	1624	1580	1538	1496	1459
				WATTS	736	749	763	774	786	797	807	816
		1.2 HP [895]	High Speed - Tap 5	CFM	2046	2004	1970	1921	1880	1835	1801	1753
				WATTS	980	997	1003	1025	1045	1059	1072	1090
RGECEB072 (6T)	2100/2700	1.2 HP [895]	Fan/Low Heat - Tap 1	CFM	1237	1182	1137	1076	996	961	906	853
				WATTS	364	373	386	396	405	409	421	431
		1.2 HP [895]	High Heat - Tap 2	CFM	2043	2004	1953	1917	1879	1828	1783	1750
				WATTS	834	850	861	876	891	906	925	938
		1.2 HP [895]	Low Cool - Tap 3	CFM	1149	1082	1030	969	891	837	781	728
				WATTS	338	345	357	365	374	383	393	403
		1.2 HP [895]	High Cool - Tap 4	CFM	2054	2002	1952	1901	1852	1817	1778	1734
				WATTS	1032	1045	1061	1081	1097	1110	1128	1134
		1.2 HP [895]	High Speed - Tap 5	CFM	2118	2068	2010	1965	1924	1884	1829	1790
				WATTS	1094	1110	1131	1151	1166	1189	1181	1189

NOTES: *Tap 4 - Factory Cooling Tap
 Pressure drops across the 3-5T CFM range (1050 - 2250): Wet coil: ~0.09 Inches W.C.
 Downflow: ~0.1 Inches W.C. Reheat coil: ~0.09 Inches W.C.

[] Designates Metric Conversions

ELECTRICAL DATA – RGECYB SERIES

		036ACT07 036ACT10	036ACU07 036ACU10	036ADT07 036ADT10	036ADU07 036ADU10	036AJT07 036AJT10	036AYT07 036AYT10	036AYU07 036AYU10
Unit Information	Unit Operating Voltage Range	187-253	187-253	414-506	414-506	187-253	518-633	518-633
	Volts	208/230	208/230	460	460	208/230	575	575
	Phase	3	3	3	3	1	3	3
	Hz	60	60	60	60	60	60	60
	Minimum Circuit Ampacity	24	29	10	11	25	9	11
	Minimum Overcurrent Protection Device Size	30	35	15	15	30	15	15
	Maximum Overcurrent Protection Device Size	35	40	15	15	35	15	15
Compressor Motor	No.	1	1	1	1	1	1	1
	Volts	208/230	208/230	460	460	208/230	575	575
	Phase	3	3	3	3	1	3	3
	Amps (RLA), Comp.1	12.8	12.8	5.1	5.1	13.5	4.5	4.5
	Amps (LRA), Comp. 1	97.5	97.5	44.3	44.3	82.5	27.1	27.1
Condenser Motor	No.	1	1	1	1	1	1	1
	Volts	208/230	208/230	460	460	208/230	575	575
	Phase	1	1	1	1	1	1	1
	HP	1/5	1/5	1/5	1/5	1/5	1/5	1/5
	Amps (FLA, each)	1	1	0.8	0.8	1	0.55	0.55
	Amps (LRA, each)	2.3	2.3	1.4	1.4	2.3	1.1	1.1
Evaporator Fan	No.	1	1	1	1	1	1	1
	Volts	208/230	208/230	460	460	208/230	208/230	208/230
	Phase	1	1	1	1	1	1	1
	HP	3/4	1-1/2	3/4	1	3/4	3/4	1-1/2
	Amps (FLA, each)	6	11.5	2.7	3.5	6	2.4	4.6
	Amps (LRA, each)	N/A	N/A	N/A	N/A	N/A	N/A	N/A

ELECTRICAL DATA – RGECYB SERIES

		036ACT07 036ACT10	036ACU07 036ACU10	036ADT07 036ADT10	036ADU07 036ADU10	036AJT07 036AJT10	036AYT07 036AYT10	036AYU07 036AYU10
Unit Information	Unit Operating Voltage Range	187-253	187-253	414-506	414-506	187-253	518-633	518-633
	Volts	208/230	208/230	460	460	208/230	575	575
	Phase	3	3	3	3	1	3	3
	Hz	60	60	60	60	60	60	60
	Minimum Circuit Ampacity	27	32	12	13	28	10	12
	Minimum Overcurrent Protection Device Size	30	40	15	15	35	15	15
	Maximum Overcurrent Protection Device Size	35	40	15	15	40	15	15
Compressor Motor	No.	1	1	1	1	1	1	1
	Volts	208/230	208/230	460	460	208/230	575	575
	Phase	3	3	3	3	1	3	3
	Amps (RLA), Comp.1	12.8	12.8	5.1	5.1	13.5	4.5	4.5
	Amps (LRA), Comp. 1	97.5	97.5	44.3	44.3	82.5	27.1	27.1
Condenser Motor	No.	1	1	1	1	1	1	1
	Volts	208/230	208/230	460	460	208/230	575	575
	Phase	1	1	1	1	1	1	1
	HP	1/5	1/5	1/5	1/5	1/5	1/5	1/5
	Amps (FLA, each)	1	1	0.8	0.8	1	0.55	0.55
	Amps (LRA, each)	2.3	2.3	1.4	1.4	2.3	1.1	1.1
Evaporator Fan	No.	1	1	1	1	1	1	1
	Volts	208/230	208/230	460	460	208/230	208/230	208/230
	Phase	1	1	1	1	1	1	1
	HP	3/4	1-1/2	3/4	1	3/4	3/4	1-1/2
	Amps (FLA, each)	6	11.5	2.7	3.5	6	2.4	4.6
	Amps (LRA, each)	N/A	N/A	N/A	N/A	N/A	N/A	N/A

ELECTRICAL DATA – RGECYB SERIES

		048ACT07 048ACT12	048ACU07 048ACU12	048ADT07 048ADT12	048ADU07 048ADU12	048AJT07 048AJT12	048AYT07 048AYT12	048AYU07 048AYU12
Unit Information	Unit Operating Voltage Range	187-253	187-253	414-506	414-506	187-253	518-633	518-633
	Volts	208/230	208/230	460	460	208/230	575	575
	Phase	3	3	3	3	1	3	3
	Hz	60	60	60	60	60	60	60
	Minimum Circuit Ampacity	24	30	13	13	30	10	12
	Minimum Overcurrent Protection Device Size	30	35	15	15	35	15	15
	Maximum Overcurrent Protection Device Size	35	40	15	15	45	15	15
Compressor Motor	No.	1	1	1	1	1	1	1
	Volts	208/230	208/230	460	460	208/230	575	575
	Phase	3	3	3	3	1	3	3
	Amps (RLA), Comp.1	12.2	12.2	6.4	6.4	17.3	5.1	5.1
	Amps (LRA), Comp. 1	120.4	120.4	48.5	48.5	126	41	41
Condenser Motor	No.	1	1	1	1	1	1	1
	Volts	208/230	208/230	460	460	208/230	575	575
	Phase	1	1	1	1	1	1	1
	HP	1/2	1/2	1/2	1/2	1/2	1/2	1/2
	Amps (FLA, each)	2.3	2.3	1.5	1.5	2.3	1	1
	Amps (LRA, each)	5.1	5.1	3.1	3.1	5.1	2.2	2.2
Evaporator Fan	No.	1	1	1	1	1	1	1
	Volts	208/230	208/230	460	460	208/230	208/230	208/230
	Phase	1	1	1	1	1	1	1
	HP	3/4	1-1/2	3/4	1	3/4	3/4	1-1/2
	Amps (FLA, each)	6	11.5	2.7	3.5	6	2.4	4.6
	Amps (LRA, each)	N/A	N/A	N/A	N/A	N/A	N/A	N/A

ELECTRICAL DATA – RGECYB SERIES

		048ACT07 048ACT12	048ACU07 048ACU12	048ADT07 048ADT12	048ADU07 048ADU12	048AJT07 048AJT12	048AYT07 048AYT12	048AYU07 048AYU12
Unit Information	Unit Operating Voltage Range	187-253	187-253	414-506	414-506	187-253	518-633	518-633
	Volts	208/230	208/230	460	460	208/230	575	575
	Phase	3	3	3	3	1	3	3
	Hz	60	60	60	60	60	60	60
	Minimum Circuit Ampacity	27	33	15	16	34	11	14
	Minimum Overcurrent Protection Device Size	30	40	20	20	40	15	15
	Maximum Overcurrent Protection Device Size	35	40	20	20	50	15	15
Compressor Motor	No.	1	1	1	1	1	1	1
	Volts	208/230	208/230	460	460	208/230	575	575
	Phase	3	3	3	3	1	3	3
	Amps (RLA), Comp.1	12.2	12.2	6.4	6.4	17.3	5.1	5.1
	Amps (LRA), Comp. 1	120.4	120.4	48.5	48.5	126	41	41
Condenser Motor	No.	1	1	1	1	1	1	1
	Volts	208/230	208/230	460	460	208/230	575	575
	Phase	1	1	1	1	1	1	1
	HP	1/2	1/2	1/2	1/2	1/2	1/2	1/2
	Amps (FLA, each)	2.3	2.3	1.5	1.5	2.3	1	1
	Amps (LRA, each)	5.1	5.1	3.1	3.1	5.1	2.2	2.2
Evaporator Fan	No.	1	1	1	1	1	1	1
	Volts	208/230	208/230	460	460	208/230	208/230	208/230
	Phase	1	1	1	1	1	1	1
	HP	3/4	1-1/2	3/4	1	3/4	3/4	1-1/2
	Amps (FLA, each)	6	11.5	2.7	3.5	6	2.4	4.6
	Amps (LRA, each)	N/A	N/A	N/A	N/A	N/A	N/A	N/A

ELECTRICAL DATA – RGECYB SERIES

		060ACT07 060ACT12	060ACU07 060ACU12	060ADT07 060ADT12	060ADU07 060ADU12	060AJT07 060AJT12	060AYT07 060AYT12	060AYU07 060AYU12
Unit Information	Unit Operating Voltage Range	187-253	187-253	414-506	414-506	187-253	518-633	518-633
	Volts	208/230	208/230	460	460	208/230	575	575
	Phase	3	3	3	3	1	3	3
	Hz	60	60	60	60	60	60	60
	Minimum Circuit Ampacity	30	34	15	15	38	13	14
	Minimum Overcurrent Protection Device Size	35	40	20	20	45	15	20
	Maximum Overcurrent Protection Device Size	45	45	20	20	50	15	20
Compressor Motor	No.	1	1	1	1	1	1	1
	Volts	208/230	208/230	460	460	208/230	575	575
	Phase	3	3	3	3	1	3	3
	Amps (RLA), Comp.1	16	16	7.7	7.7	21.8	6.4	6.4
	Amps (LRA), Comp. 1	156.4	156.4	58.1	58.1	143	47.8	47.8
Condenser Motor	No.	1	1	1	1	1	1	1
	Volts	208/230	208/230	460	460	208/230	575	575
	Phase	1	1	1	1	1	1	1
	HP	1/2	1/2	1/2	1/2	1/2	1/2	1/2
	Amps (FLA, each)	2.3	2.3	1.5	1.5	2.3	1	1
	Amps (LRA, each)	5.1	5.1	3.1	3.1	5.1	2.2	2.2
Evaporator Fan	No.	1	1	1	1	1	1	1
	Volts	208/230	208/230	460	460	208/230	208/230	208/230
	Phase	1	1	1	1	1	1	1
	HP	1	1-1/2	1	1-1/5	1	1	1-1/2
	Amps (FLA, each)	7.6	11.5	3.5	3.7	7.6	3.04	4.6
	Amps (LRA, each)	N/A	N/A	N/A	N/A	N/A	N/A	N/A

ELECTRICAL DATA – RGECYB SERIES

		060ACT07 060ACT12	060ACU07 060ACU12	060ADT07 060ADT12	060ADU07 060ADU12	060AJT07 060AJT12	060AYT07 060AYT12	060AYU07 060AYU12
Unit Information	Unit Operating Voltage Range	187-253	187-253	414-506	414-506	187-253	518-633	518-633
	Volts	208/230	208/230	460	460	208/230	575	575
	Phase	3	3	3	3	1	3	3
	Hz	60	60	60	60	60	60	60
	Minimum Circuit Ampacity	33	37	17	17	41	14	15
	Minimum Overcurrent Protection Device Size	40	45	20	20	50	15	20
	Maximum Overcurrent Protection Device Size	45	50	20	20	60	15	20
Compressor Motor	No.	1	1	1	1	1	1	1
	Volts	208/230	208/230	460	460	208/230	575	575
	Phase	3	3	3	3	1	3	3
	Amps (RLA), Comp.1	16	16	7.7	7.7	21.8	6.4	6.4
	Amps (LRA), Comp. 1	156.4	156.4	58.1	58.1	143	47.8	47.8
Condenser Motor	No.	1	1	1	1	1	1	1
	Volts	208/230	208/230	460	460	208/230	575	575
	Phase	1	1	1	1	1	1	1
	HP	1/2	1/2	1/2	1/2	1/2	1/2	1/2
	Amps (FLA, each)	2.3	2.3	1.5	1.5	2.3	1	1
	Amps (LRA, each)	5.1	5.1	3.1	3.1	5.1	2.2	2.2
Evaporator Fan	No.	1	1	1	1	1	1	1
	Volts	208/230	208/230	460	460	208/230	208/230	208/230
	Phase	1	1	1	1	1	1	1
	HP	1	1-1/2	1	1-1/5	1	1	1-1/2
	Amps (FLA, each)	7.6	11.5	3.5	3.7	7.6	3.04	4.6
	Amps (LRA, each)	N/A	N/A	N/A	N/A	N/A	N/A	N/A

ELECTRICAL DATA – RGECYB SERIES

		072ACT07 072ACT12	072ACU07 072ACU12	072ADT07 072ADT12	072ADU07 072ADU12	072AYT07 072AYT12	072AYU07 072AYU12
Unit Information	Unit Operating Voltage Range	187-253	187-253	414-506	414-506	518-633	518-633
	Volts	208/230	208/230	460	460	575	575
	Phase	3	3	3	3	3	3
	Hz	60	60	60	60	60	60
	Minimum Circuit Ampacity	38	38	18	18	13	13
	Minimum Overcurrent Protection Device Size	45	45	20	20	15	15
	Maximum Overcurrent Protection Device Size	50	50	25	25	15	15
Compressor Motor	No.	1	1	1	1	1	1
	Volts	208/230	208/230	460	460	575	575
	Phase	3	3	3	3	3	3
	Amps (RLA), Comp.1	19.2	19.2	9.1	9.1	6.2	6.2
	Amps (LRA), Comp. 1	162	162	70.8	70.8	58.2	58.2
Condenser Motor	No.	1	1	1	1	1	1
	Volts	208/230	208/230	460	460	575	575
	Phase	1	1	1	1	1	1
	HP	3/4	3/4	3/4	3/4	3/4	3/4
	Amps (FLA, each)	4.2	4.2	2.3	2.3	1.2	1.2
	Amps (LRA, each)	10.1	10.1	4.9	4.9	3.4	3.4
Evaporator Fan	No.	1	1	1	1	1	1
	Volts	208/230	208/230	460	460	208/230	208/230
	Phase	1	1	1	1	1	1
	HP	1-1/5	1-1/5	1-1/5	1-1/5	1-1/5	1-1/5
	Amps (FLA, each)	9.6	9.6	3.7	3.7	3.8	3.8
	Amps (LRA, each)	N/A	N/A	N/A	N/A	N/A	N/A

ELECTRICAL DATA – RGECEYB SERIES

		072ACT07 072ACT12	072ACU07 072ACU12	072ADT07 072ADT12	072ADU07 072ADU12
		with HUMIDIDRY			
Unit Information	Unit Operating Voltage Range	187-253	187-253	414-506	414-506
	Volts	208/230	208/230	460	460
	Phase	3	3	3	3
	Hz	60	60	60	60
	Minimum Circuit Ampacity	39	39	18	18
	Minimum Overcurrent Protection Device Size	45	45	20	20
	Maximum Overcurrent Protection Device Size	50	50	25	25
Compressor Motor	No.	1	1	1	1
	Volts	208/230	208/230	460	460
	Phase	3	3	3	3
	Amps (RLA), Comp.1	19.2	19.2	9.1	9.1
	Amps (LRA), Comp. 1	162	162	70.8	70.8
Condenser Motor	No.	1	1	1	1
	Volts	208/230	208/230	460	460
	Phase	1	1	1	1
	HP	3/4	3/4	3/4	3/4
	Amps (FLA, each)	5.3	5.3	2.3	2.3
	Amps (LRA, each)	N/A	N/A	N/A	N/A
Evaporator Fan	No.	1	1	1	1
	Volts	208/230	208/230	460	460
	Phase	1	1	1	1
	HP	1-1/5	1-1/5	1-1/5	1-1/5
	Amps (FLA, each)	9.6	9.6	3.7	3.7
	Amps (LRA, each)	N/A	N/A	N/A	N/A

ELECTRICAL DATA – RGECYB SERIES

		072ACT07 072ACT12	072ACU07 072ACU12	072ADT07 072ADT12	072ADU07 072ADU12	072AYT07 072AYT12	072AYU07 072AYU12
Unit Information	Unit Operating Voltage Range	187-253	187-253	414-506	414-506	518-633	518-633
	Volts	208/230	208/230	460	460	575	575
	Phase	3	3	3	3	3	3
	Hz	60	60	60	60	60	60
	Minimum Circuit Ampacity	41	41	20	20	14	14
	Minimum Overcurrent Protection Device Size	50	50	25	25	20	20
	Maximum Overcurrent Protection Device Size	60	60	25	25	20	20
Compressor Motor	No.	1	1	1	1	1	1
	Volts	208/230	208/230	460	460	575	575
	Phase	3	3	3	3	3	3
	Amps (RLA), Comp.1	19.2	19.2	9.1	9.1	6.2	6.2
	Amps (LRA), Comp. 1	162	162	70.8	70.8	58.2	58.2
Condenser Motor	No.	1	1	1	1	1	1
	Volts	208/230	208/230	460	460	575	575
	Phase	1	1	1	1	1	1
	HP	3/4	3/4	3/4	3/4	3/4	3/4
	Amps (FLA, each)	4.2	4.2	2.3	2.3	1.2	1.2
	Amps (LRA, each)	10.1	10.1	4.9	4.9	3.4	3.4
Evaporator Fan	No.	1	1	1	1	1	1
	Volts	208/230	208/230	460	460	208/230	208/230
	Phase	1	1	1	1	1	1
	HP	1-1/5	1-1/5	1-1/5	1-1/5	1-1/5	1-1/5
	Amps (FLA, each)	9.6	9.6	3.7	3.7	3.8	3.8
	Amps (LRA, each)	N/A	N/A	N/A	N/A	N/A	N/A

ELECTRICAL DATA – RGECYB SERIES

		072ACT07 072ACT12	072ACU07 072ACU12	072ADT07 072ADT12	072ADU07 072ADU12
		with HUMIDIDRY			
Unit Information	Unit Operating Voltage Range	187-253	187-253	414-506	414-506
	Volts	208/230	208/230	460	460
	Phase	3	3	3	3
	Hz	60	60	60	60
	Minimum Circuit Ampacity	42	42	20	20
	Minimum Overcurrent Protection Device Size	50	50	25	25
	Maximum Overcurrent Protection Device Size	60	60	25	25
Compressor Motor	No.	1	1	1	1
	Volts	208/230	208/230	460	460
	Phase	3	3	3	3
	Amps (RLA), Comp.1	19.2	19.2	9.1	9.1
	Amps (LRA), Comp. 1	162	162	70.8	70.8
Condenser Motor	No.	1	1	1	1
	Volts	208/230	208/230	460	460
	Phase	1	1	1	1
	HP	3/4	3/4	3/4	3/4
	Amps (FLA, each)	5.3	5.3	2.3	2.3
	Amps (LRA, each)	N/A	N/A	N/A	N/A
Evaporator Fan	No.	1	1	1	1
	Volts	208/230	208/230	460	460
	Phase	1	1	1	1
	HP	1-1/5	1-1/5	1-1/5	1-1/5
	Amps (FLA, each)	9.6	9.6	3.7	3.7
	Amps (LRA, each)	N/A	N/A	N/A	N/A

A2L REFRIGERANT INSTALLATION SAFETY DATA

	RGECYB036	RGECYB036 w/HumidiDry	RGECYB048	RGECYB048 w/HumidiDry	RGECYB060	RGECYB060 w/HumidiDry	RGECYB072	RGECYB072 w/HumidiDry	
Refrigerant Charge weight (oz)	72	101	67	110	80	105	85	123	
Minimum circulation airflow, Qmin (cfm)	122	171	113	186	135	178	144	208	
Installed Altitude (Ft. Above Sea Level)	Altitude Adjustment Factor	Minimum Total Conditioned Room Area, TAmin (Sq. Ft.)							
0	1.000	67	95	63	103	75	98	80	115
1000	1.025	69	97	64	106	77	101	82	118
2000	1.051	71	99	66	108	79	103	84	121
3000	1.078	73	102	68	111	81	106	86	124
4000	1.107	75	105	70	114	83	109	88	128
5000	1.138	77	108	71	117	85	112	91	131
6000	1.170	79	111	73	121	88	115	93	135
6500	1.187	80	112	75	122	89	117	95	137

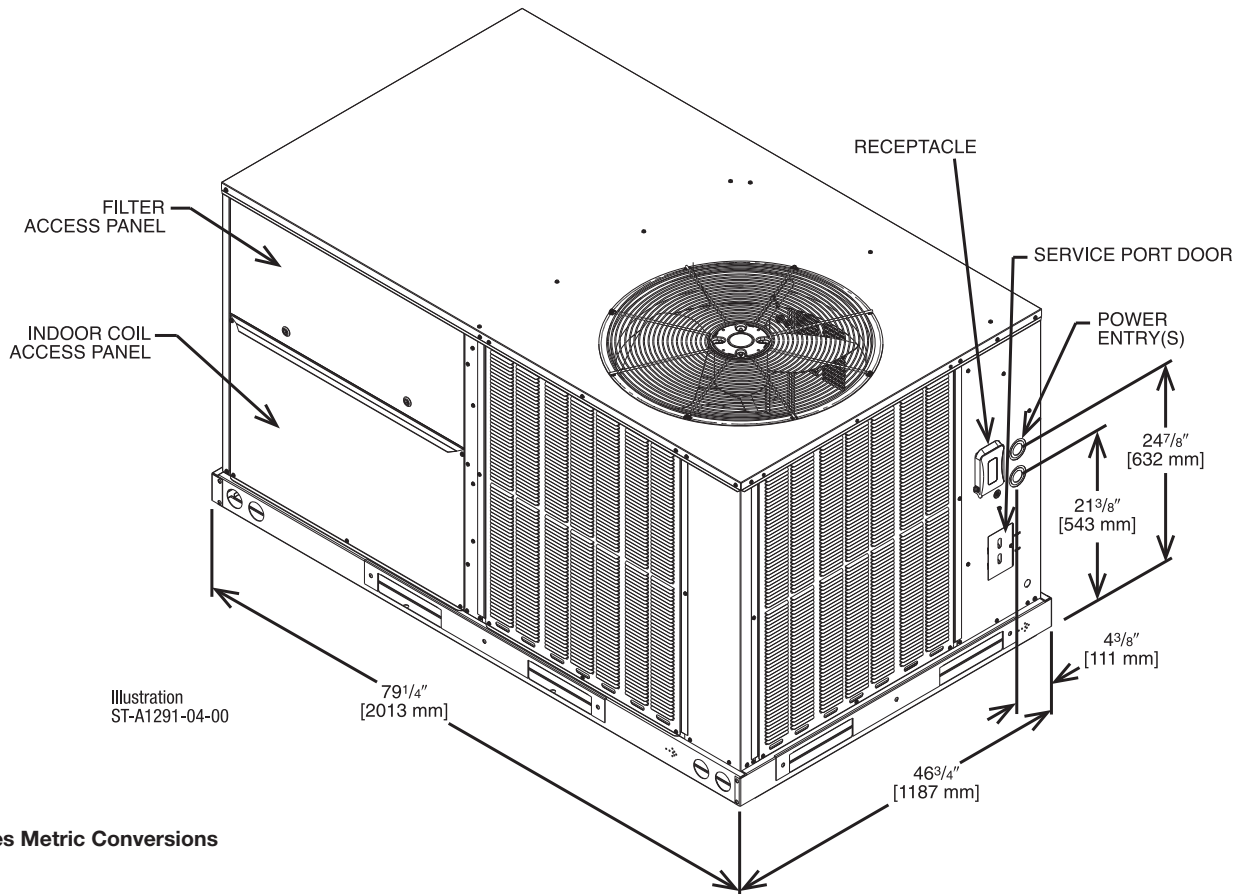
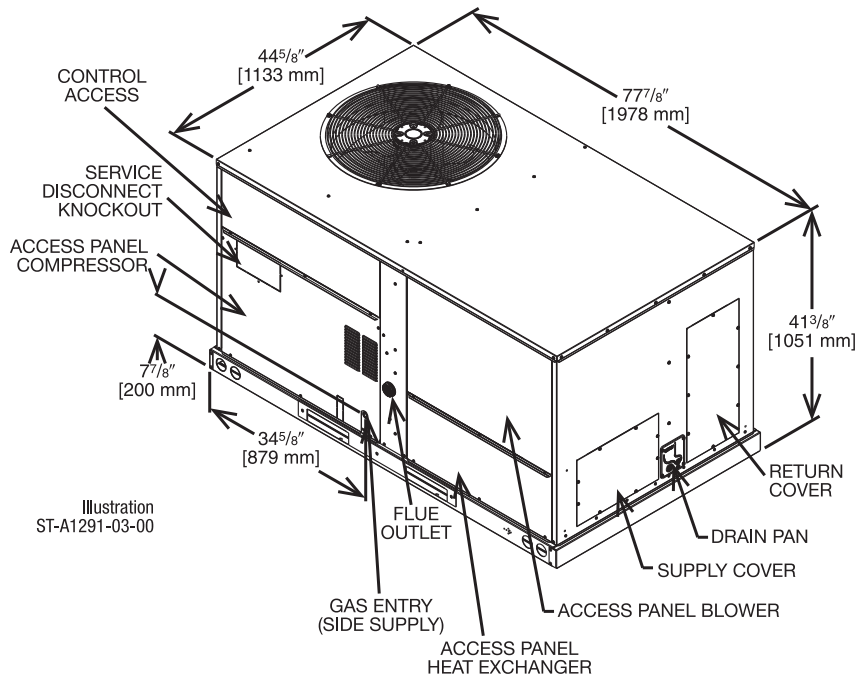

[] Designates Metric Conversions

SUPPLY AND RETURN DIMENSIONS FOR HORIZONTAL APPLICATIONS (SIDE VIEW)

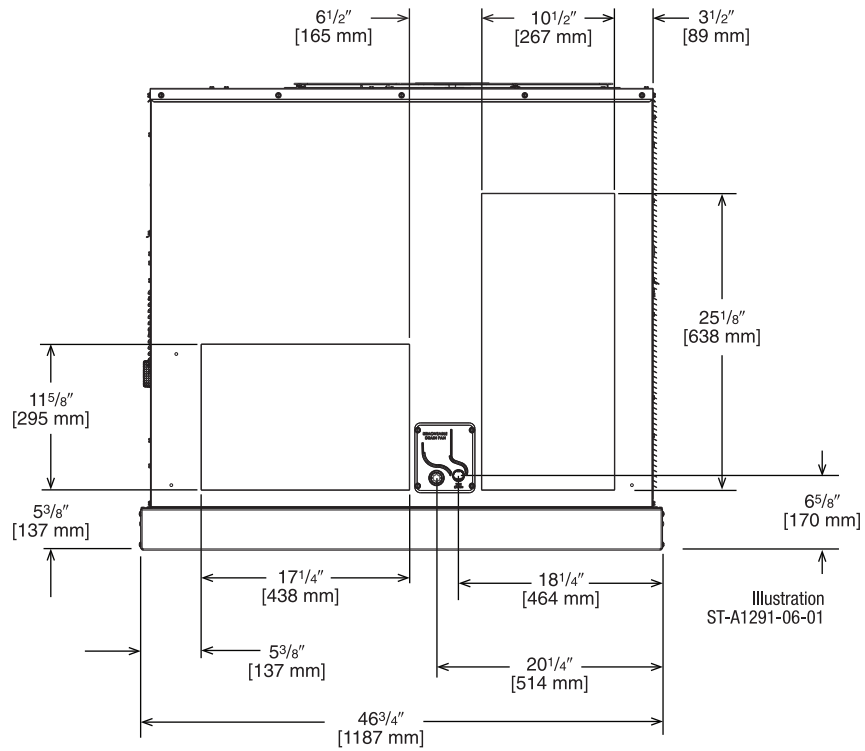

SUPPLY AND RETURN DIMENSIONS FOR DOWNFLOW APPLICATIONS (BOTTOM VIEW)

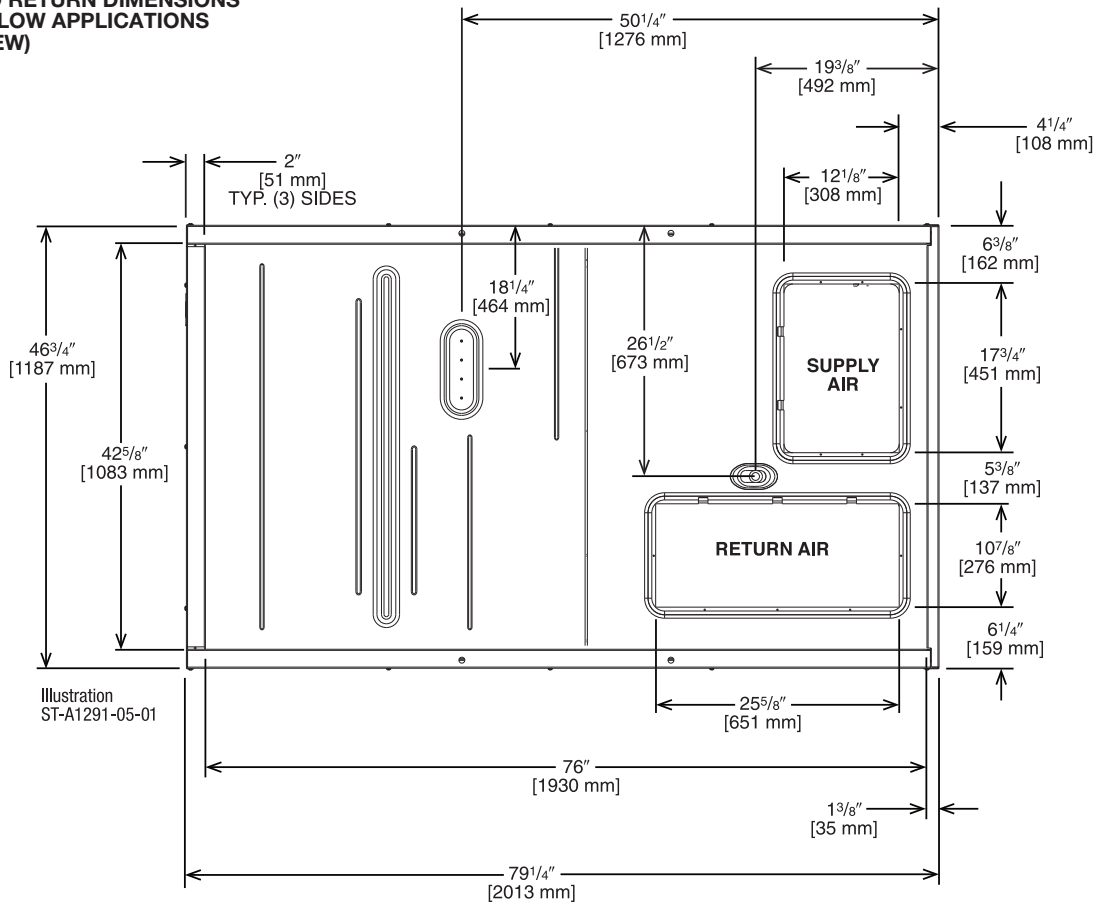

[] Designates Metric Conversions

WEIGHTS

Capacity Tons [kW]	Corner Weights by Percentage			
	A	B	C	D
3.0-6.0 [10.6-21.1]	21%	40%	12%	27%

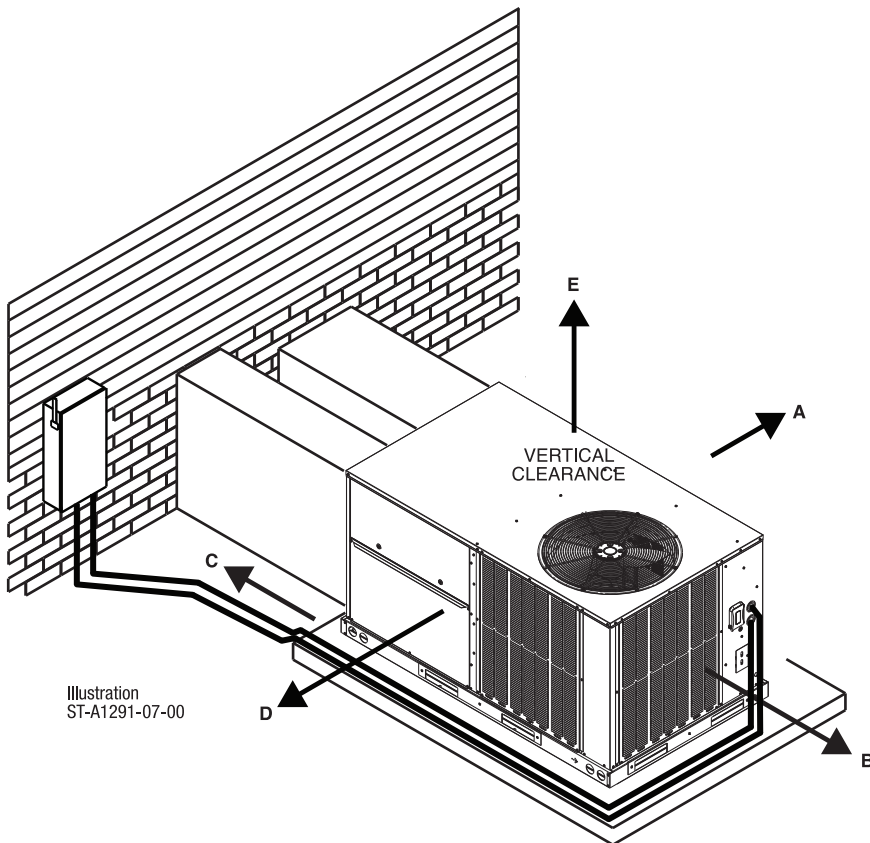
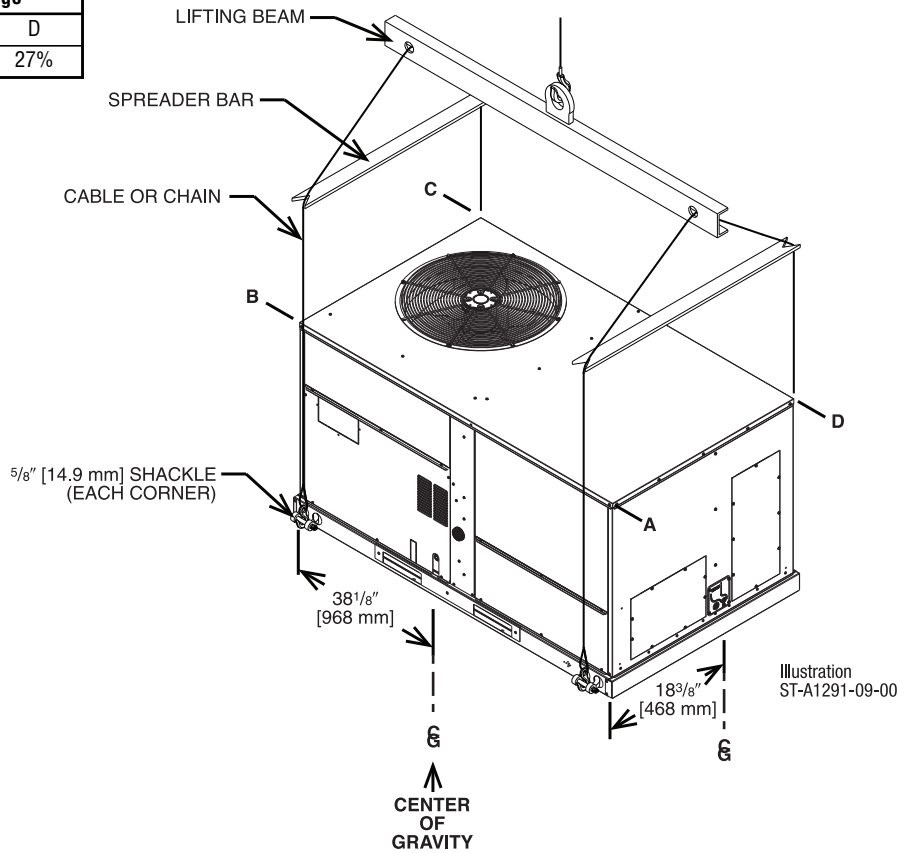

CLEARANCES

THE FOLLOWING MINIMUM CLEARANCES MUST BE OBSERVED FOR PROPER UNIT PERFORMANCE AND SERVICEABILITY.

RECOMMENDED CLEARANCE In. [mm]	LOCATION
48 [1219]	A - FRONT
24 [609]	B - CONDENSER END
48 [1219] ①	C - DUCT END
24 [609] ②	*D - FILTER SIDE
60 [1524]	E - ABOVE

① 18" [457 mm] MINIMUM IF DRAINPAN WILL NOT BE REMOVED.

② 48" [1219 MM] MINIMUM IF ECONOMIZER IS INSTALLED.

[] Designates Metric Conversions

FIELD-INSTALLED ACCESSORY EQUIPMENT

Accessory	Model Number	Shipping Weight Lbs. [kg]	Installed Weight Lbs. [kg]	Factory Installation Available?
Comfort Alert (1 Phase) DDC	RXXR-AZ03	3 [1.5]	2 [0.9]	Yes
Comfort Alert (1 Phase) Non-DDC	RXXR-AZ04	3 [1.5]	2 [0.9]	Yes
Comfort Alert (3 Phase) DDC	RXXR-AZ01	3 [1.5]	2 [0.9]	Yes
Comfort Alert (3 Phase) Non-DDC	RXXR-AZ02	3 [1.5]	2 [0.9]	Yes
Communication Card, BACnet	RXXR-AY01	1 [0.5]	1 [0.5]	No
Communication Card, LonWorks	RXXR-AY02	1 [0.5]	1 [0.5]	No
Concentric Adapter 3-4 Ton Drop	RXMC-DC01	35 [15.9]	30 [13.6]	No
Concentric Adapter 5-6 Ton Drop	RXMC-DC02	40 [18.2]	35 [15.9]	No
Concentric Diffuser 3-4 Ton Drop	RXRN-AED1800	35 [15.9]	30 [13.6]	No
Concentric Diffuser 5-6 Ton Drop	RXRN-AED2000	35 [15.9]	30 [13.6]	No
Concentric Diffuser 3-4 Ton Flush	RXRN-AEF1800	30 [13.6]	25 [11.3]	No
Concentric Diffuser 5-6 Ton Flush	RXRN-AEF2000	30 [13.6]	25 [11.3]	No
Convenience Outlet, Nonpowered	RXXR-BN01	2 [1.0]	1.5 [0.7]	Yes
Dual Enthalpy Kit (for Honeywell Jade)	RXXR-BV01	1 [0.5]	1 [0.5]	No
Dual Enthalpy Kit DDC (for Honeywell DDC)	RXXR-BV02	1 [0.5]	1 [0.5]	No
Dual Enthalpy, Temperature and Humidity Sensor (for Ruskin Basic Controller)	PD955878	1 [0.5]	1 [0.5]	No
Dual Enthalpy, Temperature and Humidity Sensor (for Siemens)	PD555460	1 [0.5]	1 [0.5]	No
Economizer Universal DDC Interface Kit	RXXR-DDC01	5 [2.7]	3.5 [1.6]	Yes
Economizer with No Controls (Downflow/Vertical) <i>MicroMetl Economizer, No Controls, Belimo Actuator</i>	RXRD-31MCDAM3	100 [45.4]	66 [29.9]	No
Economizer w/Single Enthalpy (Downflow/Vertical) <i>MicroMetl Economizer with Honeywell Jade Controls</i>	RXRD-01MCDAM3	100 [45.4]	66 [29.9]	Yes
Economizer w/Single Enthalpy (Downflow/Vertical) <i>Ruskin Rooftop Systems with RRS Basic Controller</i>	RXRD-41MCDAM3	100 [45.4]	66 [29.9]	No
Economizer w/Single Enthalpy (Downflow/Vertical) <i>MicroMetl Economizer with Siemens Controls</i>	RXRD-11MCDAM3	100 [45.4]	66 [29.9]	No
Economizer-w/Single Enthalpy (Downflow/Vertical) DDC <i>MicroMetl Economizer with Honeywell DDC Controls</i>	RXRD-01MCDAM3	72 [32.7]	69 [31.3]	Yes
Economizer w/Single Enthalpy (Horizontal) <i>MicroMetl Economizer with Honeywell Jade Controls</i>	RXRD-01MCHAM3	72 [32.7]	69 [31.3]	No
Economizer w/Single Enthalpy (Horizontal) <i>MicroMetl Economizer with Siemens Controls</i>	RXRD-11MCHAM3	72 [32.7]	69 [31.3]	No
Economizer w/Single Enthalpy (Horizontal) <i>Ruskin Rooftop Systems with RRS Basic Controller</i>	RXRD-41MCHAM3	72 [32.7]	69 [31.3]	No
Economizer w/Single Enthalpy (Horizontal) DDC <i>MicroMetl Economizer with Honeywell DDC Controls</i>	RXRD-01MCHBM3	72 [32.7]	69 [31.3]	No
Flue Diverter (RGEC 75K, 100K & 120K)	RXXR-DEG03	5 [2.3]	4 [1.8]	No
Freeze Stat Kit	RXXR-AM05	2 [1.0]	1.5 [0.7]	Yes
Fresh Air Damper, Manual	RXRF-ACA1	22 [10.0]	18 [8.2]	No
Fresh Air Damper, Motorized	RXRF-ACB1	53 [24.0]	43 [19.5]	No
Low-Ambient Control Kit	RXRZ-A04	4 [1.8]	3 [1.4]	Yes
LP Kit (RGEC 75K, 120K)	RXGJ-FP40	2 [1.0]	1 [0.5]	No
LP Kit (RGEC 100K)	RXGJ-FP41	2 [1.0]	1 [0.5]	No
MERV 8 Filter	RXMF-M08A21616	2 [0.9]	1 [0.45]	No
MERV 13 Filter	RXMF-M13A21616	2 [0.9]	1 [0.45]	No
Outdoor Coil Louver Kit	RXXR-ADD04C	30 [13.6]	25 [11.3]	Yes

[] Designates Metric Conversions

FIELD-INSTALLED ACCESSORY EQUIPMENT (CON'T.)

Accessory	Model Number	Shipping Weight Lbs. [kg]	Installed Weight Lbs. [kg]	Factory Installation Available?
Power Exhaust (230V) <i>Horizontal MicroMetl</i>	RXXR-CCF03C	42 [19.1]	39 [17.7]	No
Power Exhaust (230V) <i>Horizontal Ruskin Rooftop Systems</i>	RXXR-RCF03C	42 [19.1]	39 [17.7]	No
Power Exhaust (230V) <i>Vertical MicroMetl</i>	RXXR-CCF02C	24 [10.9]	21 [9.5]	No
Power Exhaust (230V) <i>Vertical Ruskin Rooftop Systems</i>	RXXR-RCF02C	24 [10.9]	21 [9.5]	No
Power Exhaust (460V) <i>Horizontal MicroMetl</i>	RXXR-CCF03D	42 [19.1]	39 [17.7]	No
Power Exhaust (460V) <i>Horizontal Ruskin Rooftop Systems</i>	RXXR-RCF03D	42 [19.1]	39 [17.7]	No
Power Exhaust (460V) <i>Vertical MicroMetl</i>	RXXR-CCF02D	20 [9.1]	17 [7.7]	No
Power Exhaust (460V) <i>Vertical Ruskin Rooftop Systems</i>	RXXR-RCF02D	20 [9.1]	17 [7.7]	No
Roofcurb, 14"	RXXG-DCC14	94 [42.6]	90 [40.8]	No
Roofcurb, 24"	RXXG-DCC24	124 [56.2]	120 [54.4]	No
Roofcurb Adapter	RXXR-DCCA	159 [72.1]	145 [65.8]	No
Sensor, Carbon Dioxide (Wall Mount)	RXXR-AR02	1 [0.5]	1 [0.5]	No
Sensor, Room Humidity	RHC-ZNS4	1 [0.5]	1 [0.5]	No
Sensor, Room Temperature and Relative Humidity	RHC-ZNS5	1 [0.5]	1 [0.5]	No
Smoke Detector, Return (Field kit)	RXXR-BS01	7 [3.2]	6 [2.7]	No
Smoke Detector, Return/ Supply (Field kit)	RXXR-BS02	5 [2.3]	4 [1.8]	No
Unfused Service Disconnect	RXXR-BP01	10 [4.5]	9 [4.1]	Yes

[] Designates Metric Conversions

COMMUNICATION CARDS



BACnet COMMUNICATION CARD RXRX-AY01

The field-installed BACnet Communication Card allows the RTU-C unit controller to communicate with a third party building management system that supports the BACnet Application Specific Controller device profile. The BACnet Communication Module plugs onto the unit RTU-C controller and allows communication between the RTU-C and the BACnet MSTP network.



LonWorks COMMUNICATION CARD RXRX-AY02

The field-installed LonWorks Communication Card allows the RTU-C unit controller to communicate with a third party building management system that supports the LonMark Space Comfort Controller (SCC) functional profile or LonMark Discharge Air Controller (DAC) functional profile. The LonMark Communication Module plugs onto the RTU-C controller and allows communication between the RTU-C and a LonWorks Network.

NON-DDC ECONOMIZER FOR DOWNFLOW DUCT INSTALLATION

Factory or Field-Installed

RXRD-01MCDAM3—Single Enthalpy (Outdoor)

RRRX-BV01—Dual Enthalpy Upgrade Kit

RRRX-AR02—Optional Wall-Mounted CO2 Sensor

- Features **Honeywell JADE** Digital Controls
- Available Factory-Installed or Field Accessory
- Gear Driven Direct Drive Actuator
- Fully Modulating (0-100%)
- Ultra Low Leak Dampers meet California Title 24 requirements and ASHRAE 90.1 2022
- AMCA 511 Certified Class 1A Leakage—1" WG of differential pressure tested to AMCA Standard 500-D
- Slip-In Design for Easy Installation
- Plug-In Polarized 12-pin Electrical Connections
- Standard Barometric Relief Damper
- Single Enthalpy with Dual Enthalpy Upgrade Kit Available
- CO2 Input Sensor Option Available
- Field Assembled Hood Ships with Economizer
- Economizer Ships Complete for Downflow Duct Application
- Field-Installed Power Exhaust Option Available
- Fault detection and diagnostics

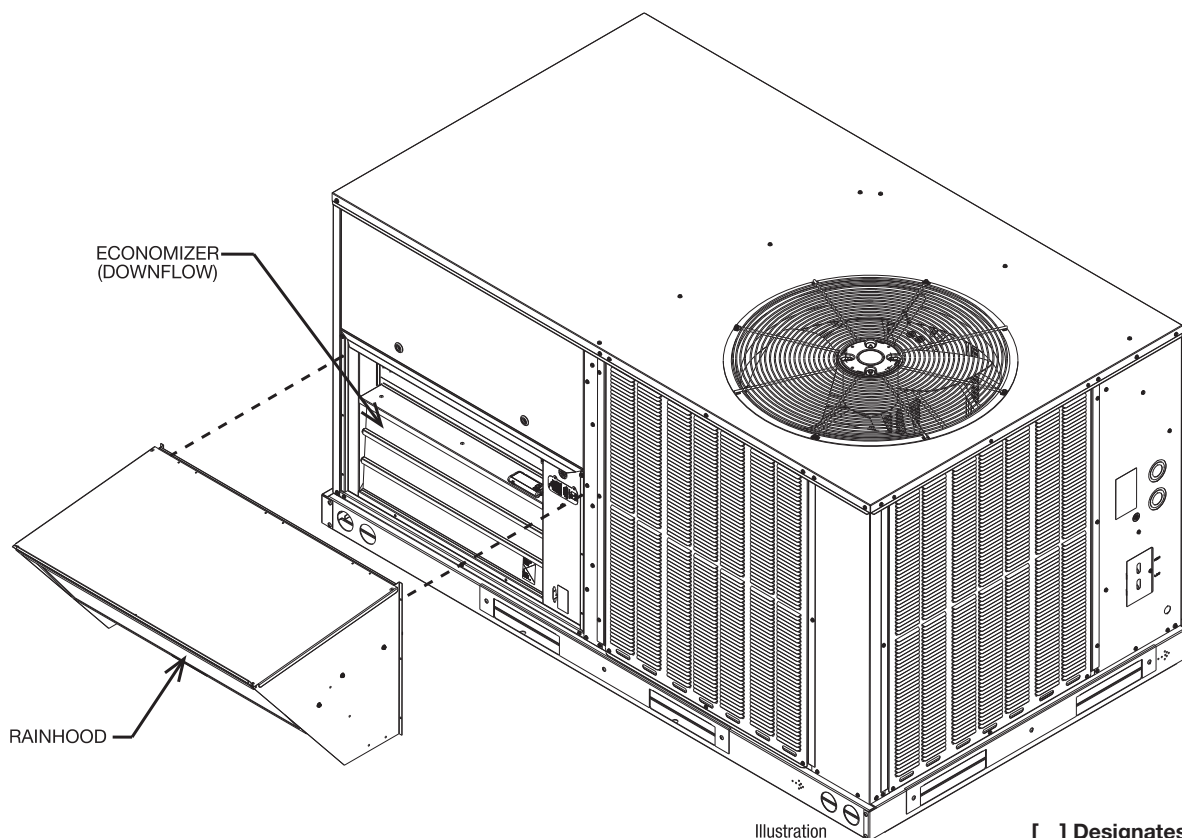
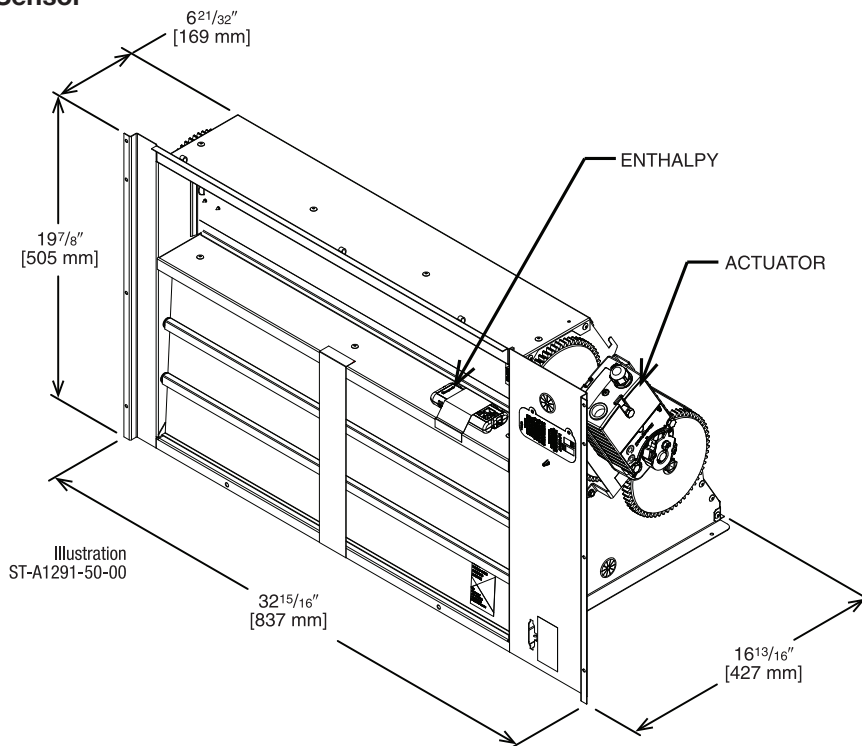

[] Designates Metric Conversions

NON-DDC ECONOMIZER FOR DOWNFLOW DUCT INSTALLATION

Field-Installed Only

RXRD-11MCDAM3—Single Enthalpy (Outdoor)

PD555460—Dual Enthalpy Upgrade Kit

RXXR-AR02—Optional Wall-Mounted CO2 Sensor

- Features **Siemens** Climatrix ECO® Economizer Controller
- Available as a Field-Installed Accessory
- Gear Driven Direct Drive Actuator
- Fully Modulating (0-100%)
- Ultra Low Leak Dampers meet California Title 24 requirements and ASHRAE 90.1 2022
- AMCA 511 Certified Class 1A Leakage—1" WG of differential pressure tested to AMCA Standard 500-D
- Slip-In Design for Easy Installation
- Plug-In Polarized 12-pin Electrical Connections
- Standard Barometric Relief Damper
- Single Enthalpy or Dry Bulb with Return Air Enthalpy Option
- CO2 Input Sensor Option Available
- Field Assembled Hood Ships with Economizer
- Economizer Ships Complete for Downflow Duct Application.
- Field-Installed Power Exhaust Option Available
- Fault detection and diagnostics

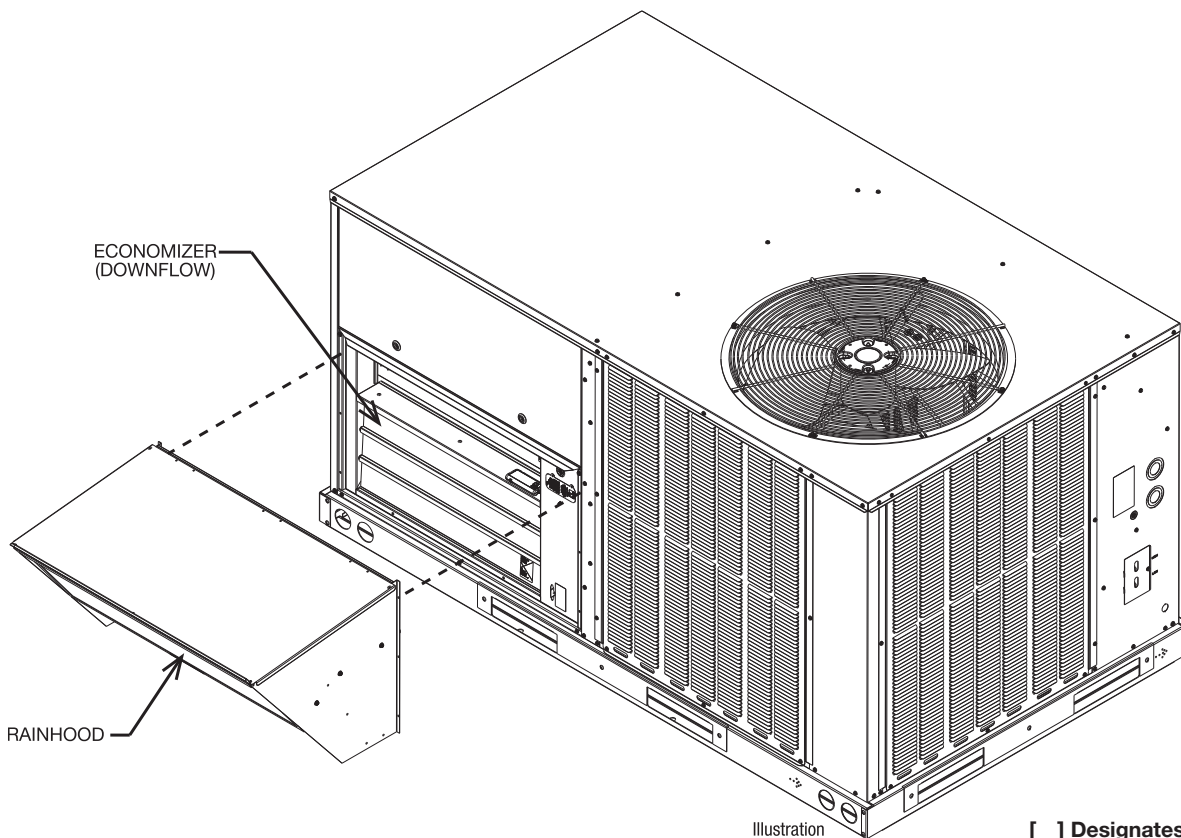
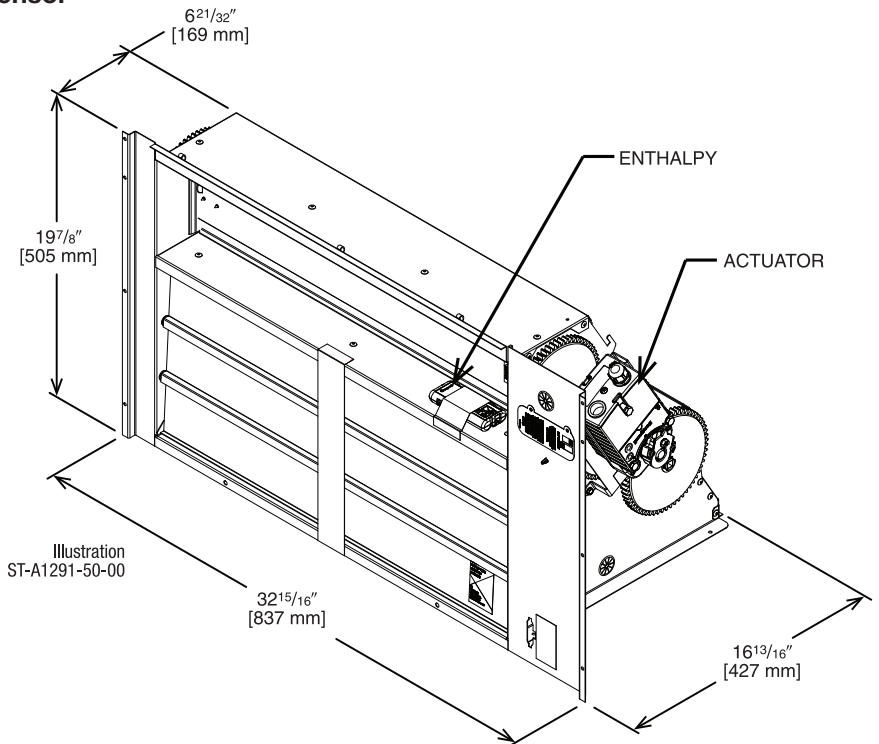

[] Designates Metric Conversions

NON-DDC VERTICAL AIRFLOW ECONOMIZER

Field-Installed Only

RXRD-41MCDAM3—Single Enthalpy (Outdoor)

PD555878—Temperature and Humidity Sensor for Dual Enthalpy (for Ruskin Basic Controller Only)

RRRX-AR02—Optional Wall-Mounted CO2 Sensor

These ultra-low leak economizer dampers meet the following minimum construction standards:

1. Frame shall be 14 to 24 gauge galvanized steel channel.
2. Damper blades are galvanized steel airfoil shaped, double skin construction of 14 gauge [2.0] equivalent thickness, 6" [152 mm] wide.
3. Blade edge seals shall be Ruskiprene™ type or equivalent suitable for -72°F [-60°C] to +275°F [+135°C] mechanically locked into the blade edge. Adhesive or clip-on type seals are unacceptable.
4. Jamb seals shall be flexible metal, compression type to prevent leakage between blade end and damper frame. Blade end overlapping frame is unacceptable.
5. Bearings shall be stainless steel or nylon bushing.
6. Axles shall be hexagonal positively locked into the damper blade.
7. Drive mechanism shall be concealed out of airstream to reduce pressure drop and noise.
8. Economizer damper is tested and rated based upon AMCA Publication 500-D.
9. RRS controls feature the Basic economizer controller with 24v actuator. Controls capable of Economizer Fault Detection and Diagnostics for code compliance.
10. Damper shall meet the leakage requirements of the International Energy Conservation Code by leaking less than 3 cfm/sq. ft. at 1" of static pressure and shall be AMCA licensed as a class 1A damper. Complies with reliability and performance requirements as specified by the California Energy Commission's Title 24 Standard and ASHRAE 90.1. Economizer dampers shall be Ruskin Rooftop Systems ECD60 model.

[] Designates Metric Conversions

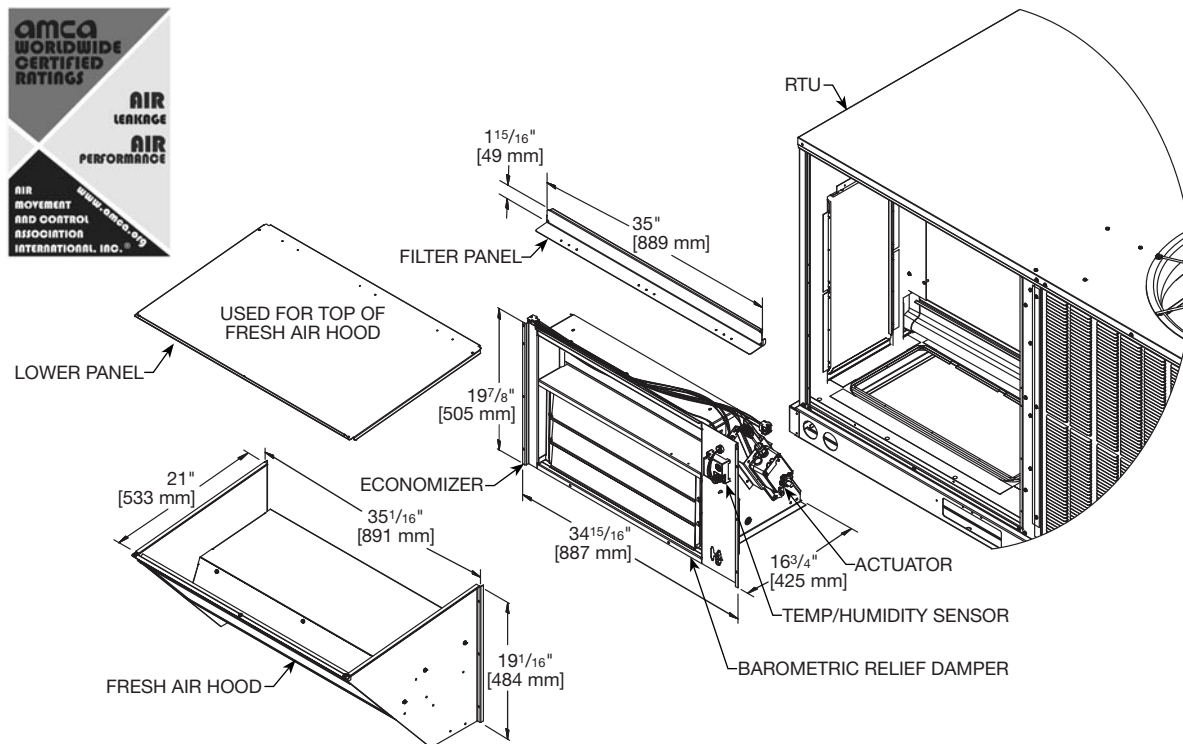

*Components not shown

NON-DDC ECONOMIZER FOR HORIZONTAL DUCT INSTALLATION

Field-Installed Only

RXRD-01MCHAM3—Single Enthalpy (Outdoor)

RXXR-BV01—Dual Enthalpy Upgrade Kit

RXXR-AR02—Wall-mounted CO2 Sensor

- Features **Honeywell JADE** Digital Controls
- Gear Driven Direct Drive Actuator
- Fully Modulating (0-100%)
- Ultra Low Leak Dampers meet California Title 24 requirements and ASHRAE 90.1 2022
- Slip-In Design for Easy Installation
- Standard Barometric Relief Damper
- Single Enthalpy with Dual Enthalpy Upgrade Kit Available
- CO2 Input Sensor Option Available
- Field Assembled Hood Ships with Economizer
- Economizer Ships Complete for Horizontal Duct Application
- Field-Installed Power Exhaust Option Available

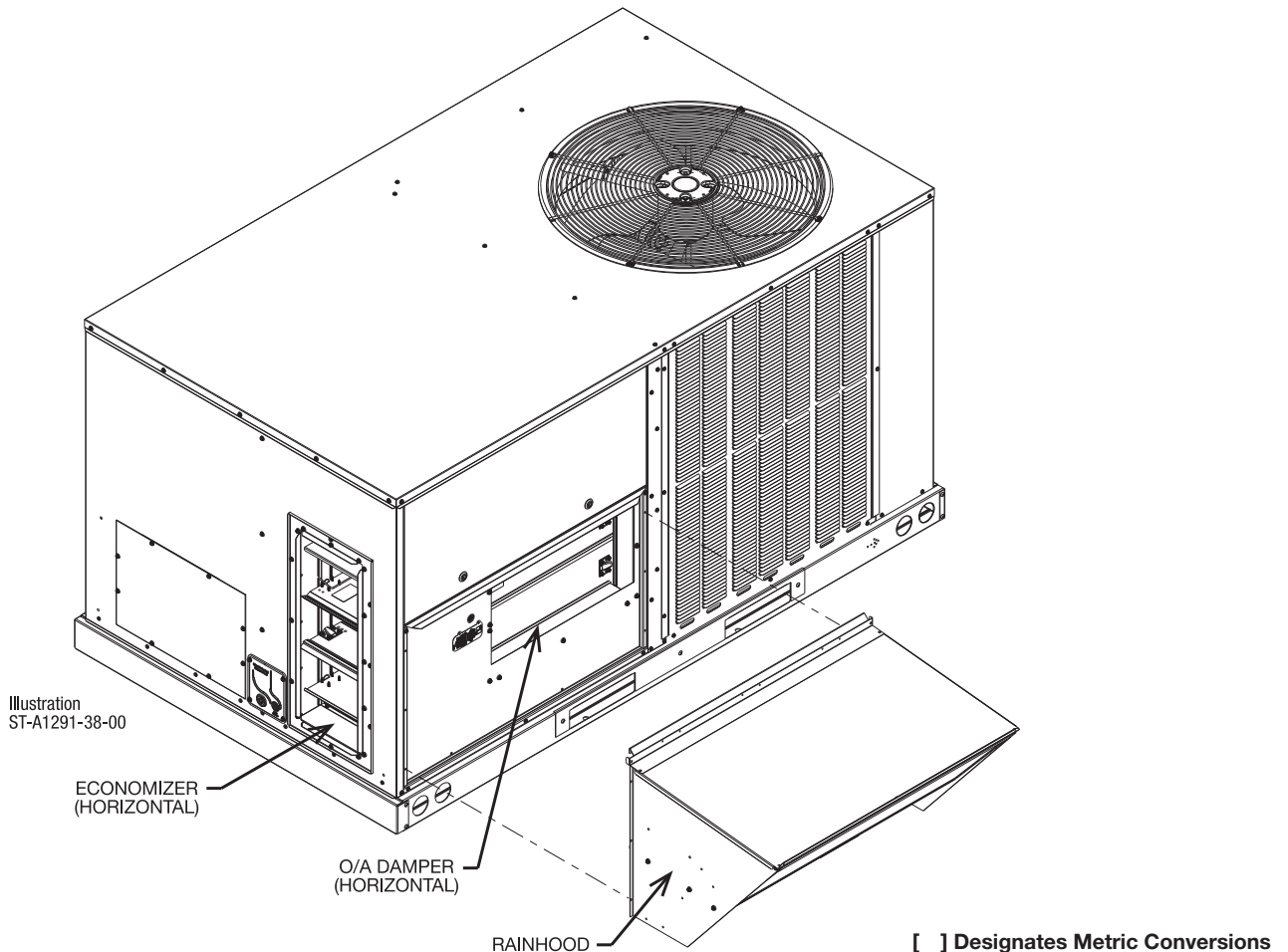
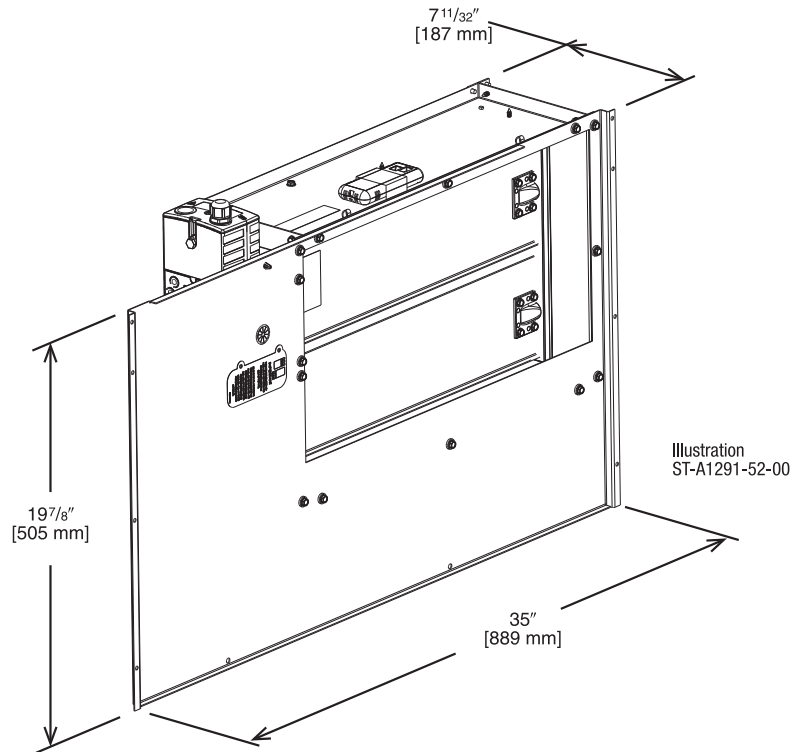

NON-DDC ECONOMIZER FOR HORIZONTAL DUCT INSTALLATION

Field-Installed Only

RXRD-11MCHAM3—Single Enthalpy (Outdoor)
PD555460—Temperature and Humidity Sensor for Dual Enthalpy (for Siemens Controllers Only)
RXXR-AR02—Optional Wall-Mounted CO2 Sensor

- Features **Siemens** Climatix ECO Economizer Controller
- Gear Driven Direct Drive Actuator
- Fully Modulating (0-100%)
- Ultra Low Leak Dampers meet California Title 24 requirements and ASHRAE 90.1 2022
- Slip-In Design for Easy Installation
- Standard Barometric Relief Damper
- Single Enthalpy with Dual Enthalpy Upgrade Kit Available
- CO2 Input Sensor Option Available
- Field Assembled Hood Ships with Economizer
- Economizer Ships Complete for Horizontal Duct Application
- Field-Installed Power Exhaust Option Available

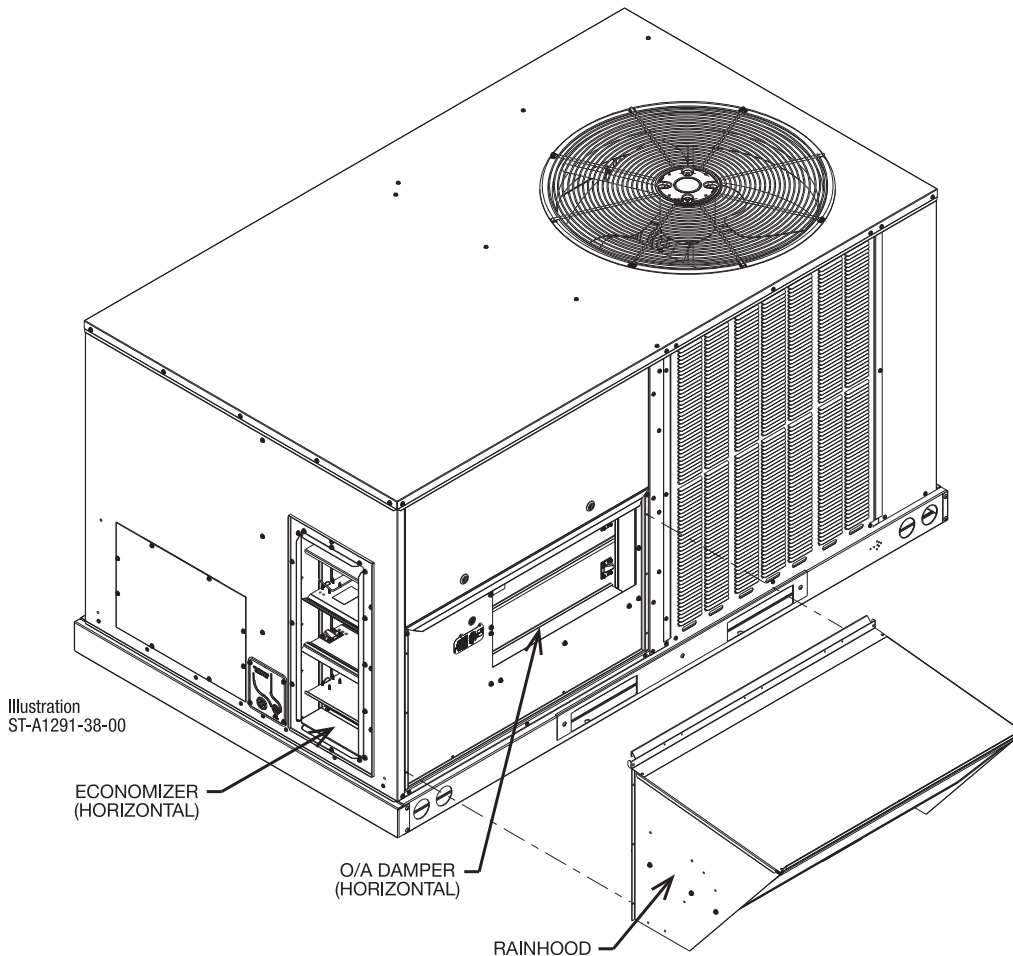
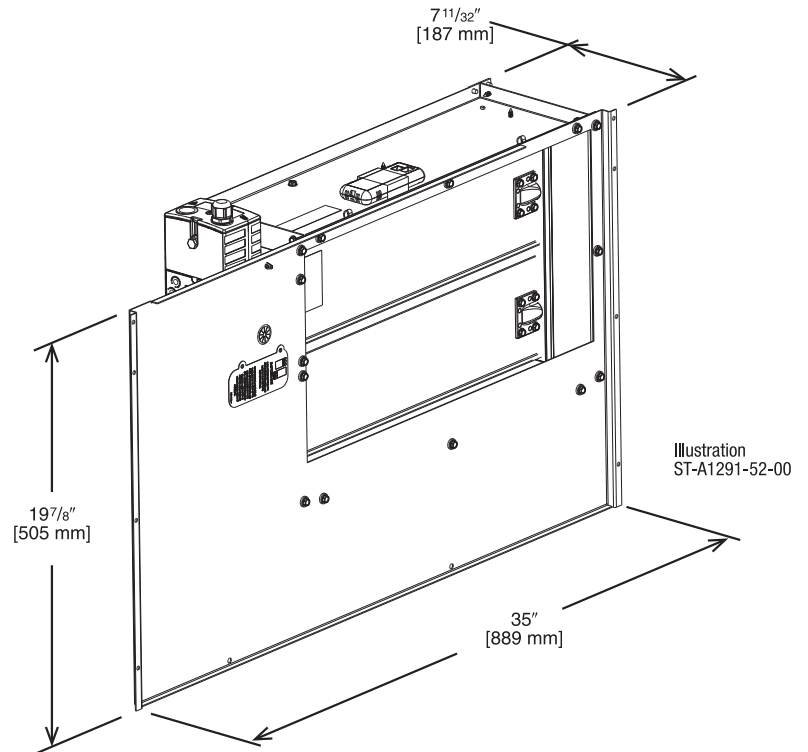

[] Designates Metric Conversions

NON-DDC HORIZONTAL AIRFLOW ECONOMIZER

Field-Installed Only

RXRD-41MCHAM3—Single Enthalpy (Outdoor)

PD555878—Temperature and Humidity Sensor for Dual Enthalpy (for Ruskin Basic Controller Only)

RXXR-AR02—Wall Mounted CO2 Sensor

These ultra-low leak economizer dampers meet the following minimum construction standards:

1. Frame shall be 14 to 24 gauge galvanized steel channel.
2. Damper blades are galvanized steel airfoil shaped, double skin construction of 14 gauge [2.0] equivalent thickness, 6" [152 mm] wide.
3. Blade edge seals shall be Ruskiprene™ type or equivalent suitable for -72°F [-60°C] to +275°F [+135°C] mechanically locked into the blade edge. Adhesive or clip-on type seals are unacceptable.
4. Jamb seals shall be flexible metal, compression type to prevent leakage between blade end and damper frame. Blade end overlapping frame is unacceptable.
5. Bearings shall be stainless steel or nylon bushing.
6. Axles shall be hexagonal positively locked into the damper blade.
7. Drive mechanism shall be concealed out of airstream to reduce pressure drop and noise.
8. Economizer damper is tested and rated based upon AMCA Publication 500-D.
9. RRS controls feature the Basic economizer controller with 24v actuator. Controls capable of Economizer Fault Detection and Diagnostics for code compliance.
10. Damper shall meet the leakage requirements of the International Energy Conservation Code by leaking less than 3 cfm/sq. ft. at 1" of static pressure and shall be AMCA licensed as a class 1A damper. Complies with reliability and performance requirements as specified by the California Energy Commission's Title 24 Standard and ASHRAE 90.1. Economizer dampers shall be Ruskin Rooftop Systems ECD60 model.

[] Designates Metric Conversions

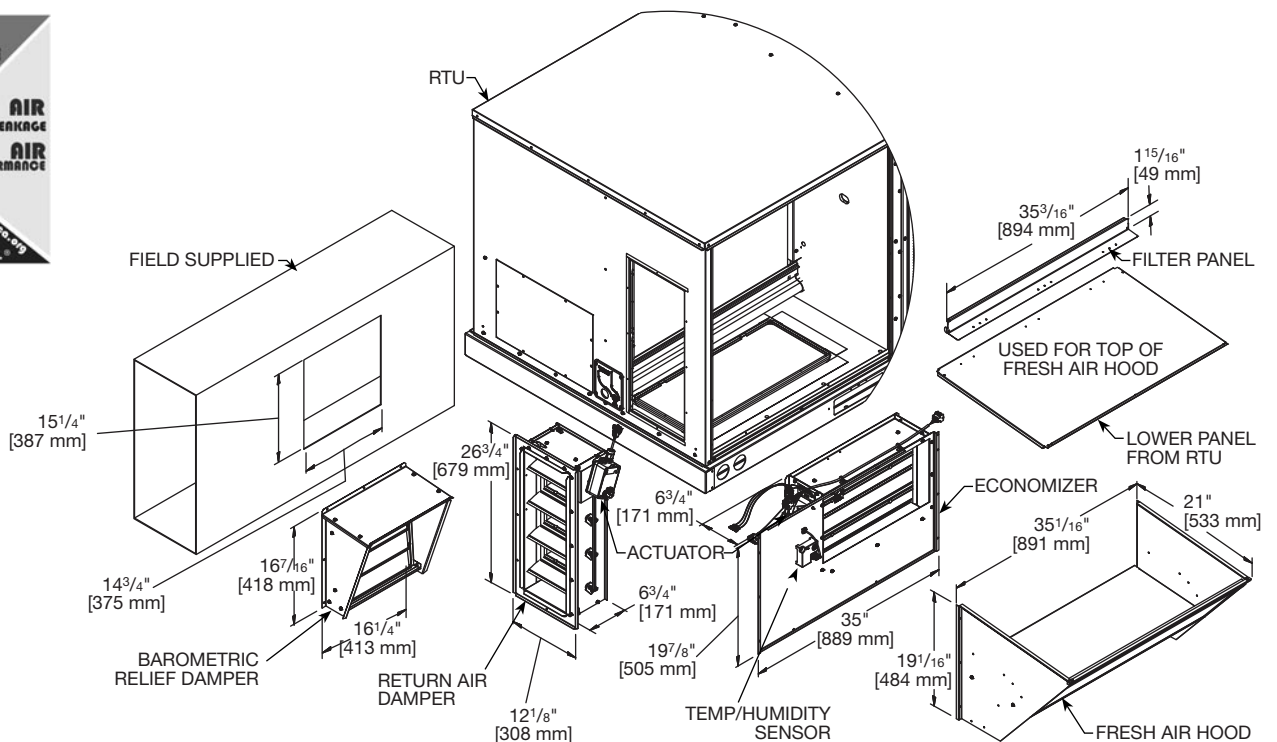

DDC — ECONOMIZER FOR DOWNFLOW DUCT INSTALLATION

Factory or Field-Installed

RXRD-01MCDBM3—Single Enthalpy (Outdoor)

RXXR-BV02—Dual Enthalpy Upgrade Kit

RXXR-AR02—Optional Wall-Mounted CO2 Sensor

- Features **Honeywell** Controls
- Available Factory-Installed or Field Accessory
- Gear Driven Direct Drive Actuator
- Fully Modulating (0-100%)
- Ultra Low Leak Dampers meet California Title 24 requirements and ASHRAE 90.1 2022
- Slip-In Design for Easy Installation
- Standard Barometric Relief Damper
- Single Enthalpy with Dual Enthalpy Upgrade Kit Available
- CO2 Input Sensor Available
- Field Assembled Hood Ships with Economizer
- Economizer Ships Complete for Downflow Duct Application
- Optional Remote Minimum Position Potentiometer (270 ohm) (Honeywell #S963B1136) is Available from Prostock
- Field-Installed Power Exhaust Available
- Prewired for Smoke Detector
- If connected to a Building Automation System (BAS), all economizer functions can be viewed on the (BAS), or 16 x 2 LCD screen
- If connected to thermostat, all economizer functions can be viewed on 16 x 2 LCD screen

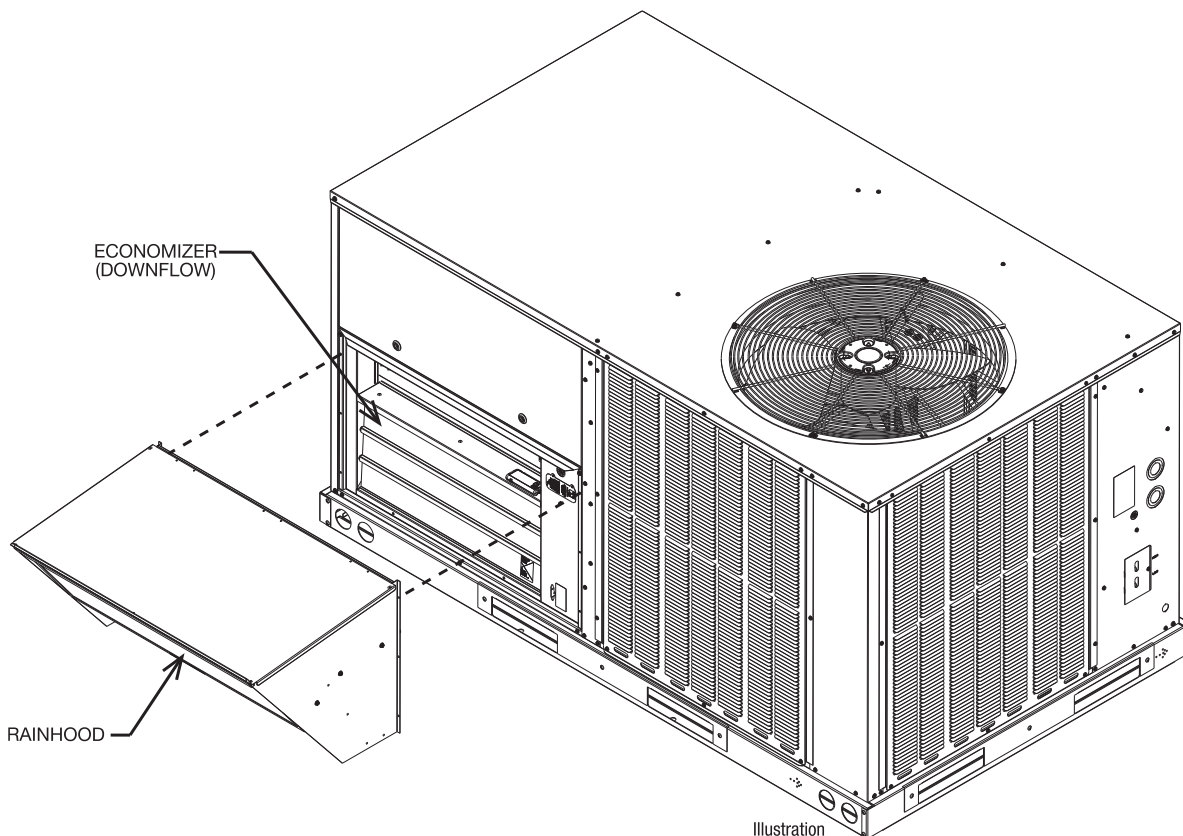
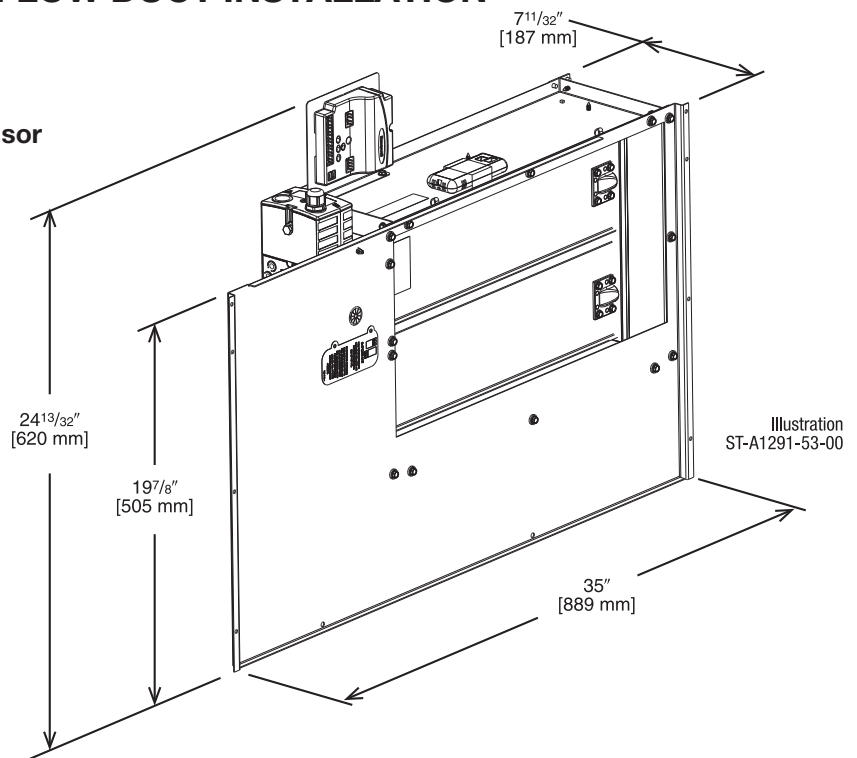

[] Designates Metric Conversions

DDC—ECONOMIZER FOR HORIZONTAL DUCT INSTALLATION

Field-Installed Only

RXRD-01MCHBM3—Single Enthalpy (Outdoor)

RXRX-BV02—Dual Enthalpy Upgrade Kit

RXRX-AR02—Wall-mounted CO2 Sensor

- Features **Honeywell** Controls
- Gear Driven Direct Drive Actuator
- Fully Modulating (0-100%)
- Ultra Low Leak Dampers meet California Title 24 requirements and ASHRAE 90.1 2022
- Slip-In Design for Easy Installation
- Standard Barometric Relief Damper
- Single Enthalpy with Dual Enthalpy Upgrade Kit Available
- CO2 Input Sensor Available
- Field Assembled Hood Ships with Economizer
- Economizer Ships Complete for Horizontal Duct Application
- Optional Remote Minimum Position Potentiometer (270 ohm) (Honeywell #S963B1136) is Available from Prostock
- Field-Installed Power Exhaust Available
- If connected to a Building Automation System (BAS), all economizer functions can be viewed on the (BAS), or 16 x 2 LCD screen
- If connected to a thermostat, all economizer functions can be viewed on 16 x 2 LCD screen

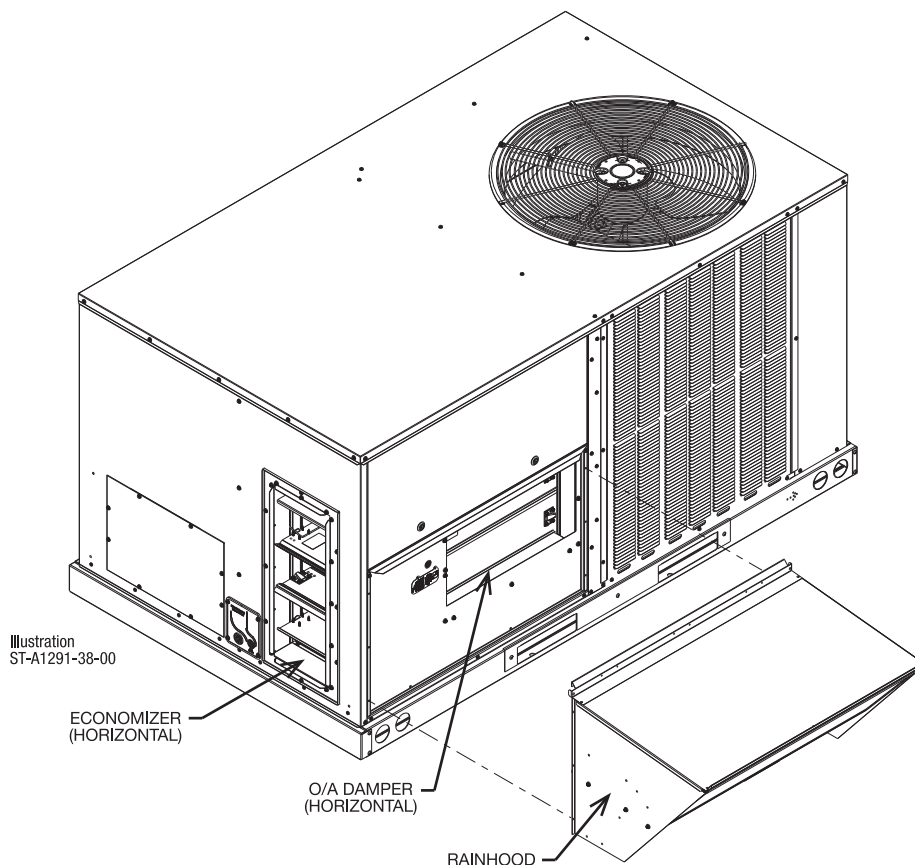
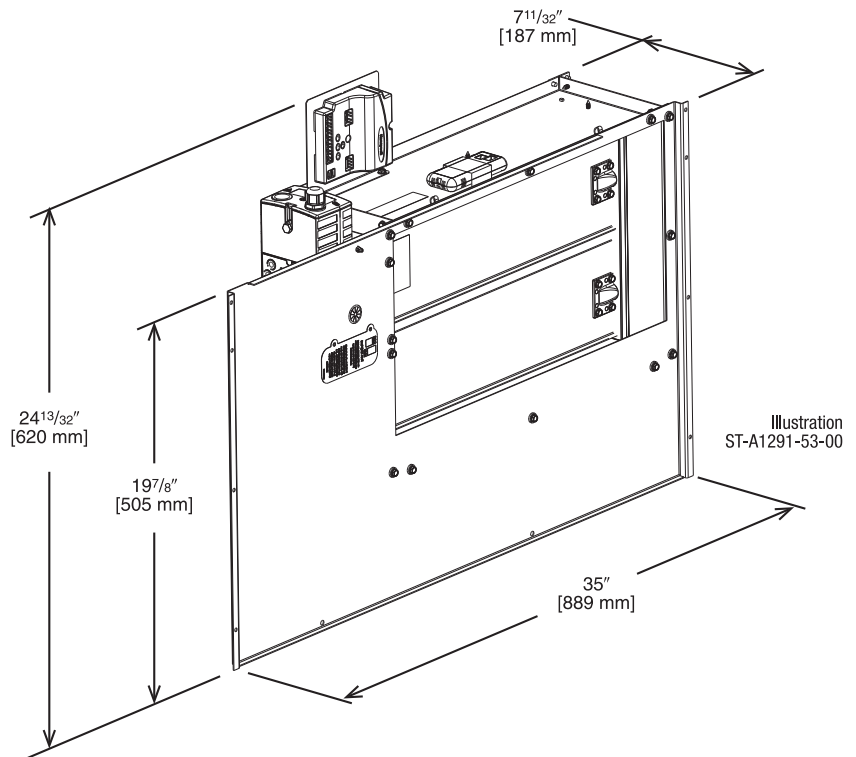

[] Designates Metric Conversions

POWER EXHAUST KIT FOR ECONOMIZERS

RXRX-CCF02*

*Voltage Code (C or D)

VERTICAL AIRFLOW

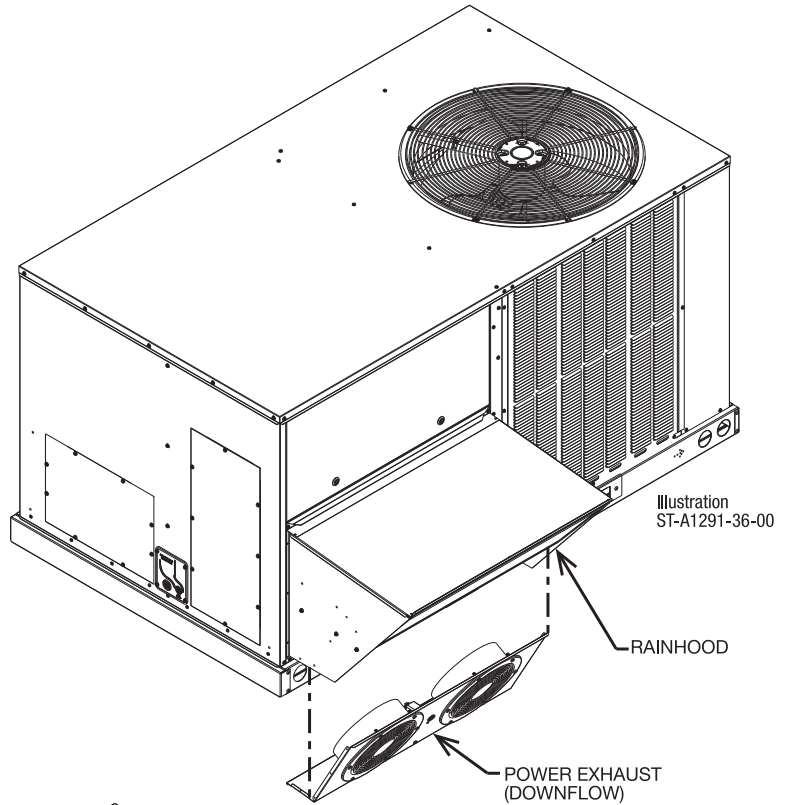

RXRX-CCF03*

*Voltage Code (C or D)

HORIZONTAL AIRFLOW

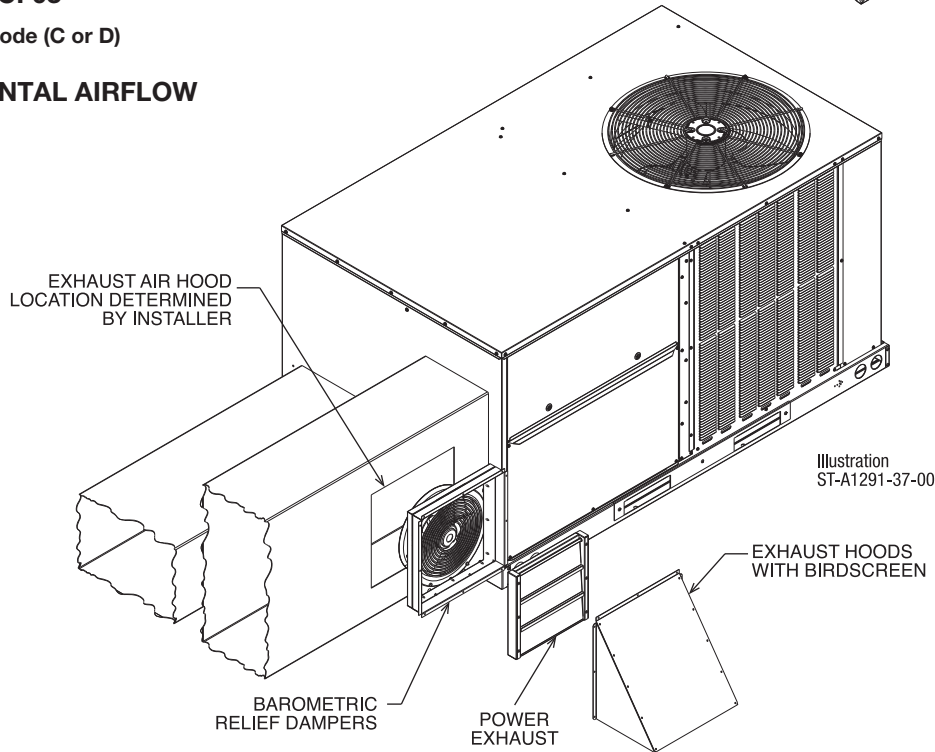

Model No.	No. of Fans	Volts	Phase	HP (ea.)	CFM [L/s]*	RPM	FLA (ea.)	LRA (ea.)
RXRX-CCF0*C	2	208-230	1	0.47	2200	3000	1.55	1.1
RXRX-CCF0*D	2	460	3	0.40	1970	2750	0.51	1.9

*CFM is per fan at 0" w.c. external static pressure.

[] Designates Metric Conversions

POWER EXHAUST KIT FOR DOWNFLOW ECONOMIZERS

RXXR-RCF02*

*Voltage Code: C, D, or Y

- Shipped completely assembled
- All wiring from control box to economizer is supplied
- Color coordinated with the unit
- Fully insulated with 1" 1.5 lb. fiberglass insulation
- Motors are factory wired and tested
- **Economizer Sold Separately**

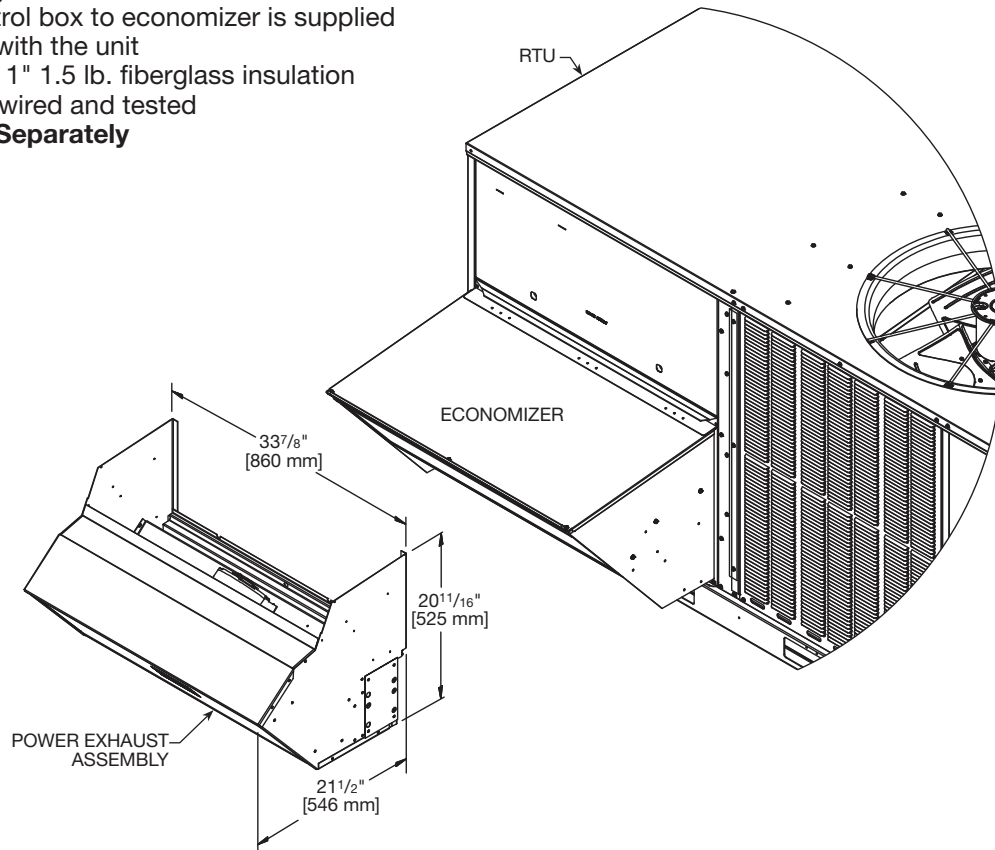

[] Designates Metric Conversions

Model No.	Volt	Phase	Motor				Unit				@ 0.1 CFM
			HP	RPM	LRA	Qty.	Cir. Qty.	FLA	MCA	Fuse Size	
RXXR-RCF02C	208-230	1	1/2	1625	5.86	1	1	2.70	3.38	6	1989
RXXR-RCF02D	460				3.33			1.34	1.68	3	
RXXR-RCF02Y	575				2.52			1.06	1.33	2	

POWER EXHAUST KIT FOR HORIZONTAL ECONOMIZERS

RXXR-RCF03*

*Voltage Code: C, D, or Y

- Shipped completely assembled
- All wiring from control box to economizer is supplied
- Color coordinated with the unit
- Fully insulated with 1" 1.5 lb. fiberglass insulation
- Motors are factory wired and tested
- **Economizer with Relief Hood Sold Separately**

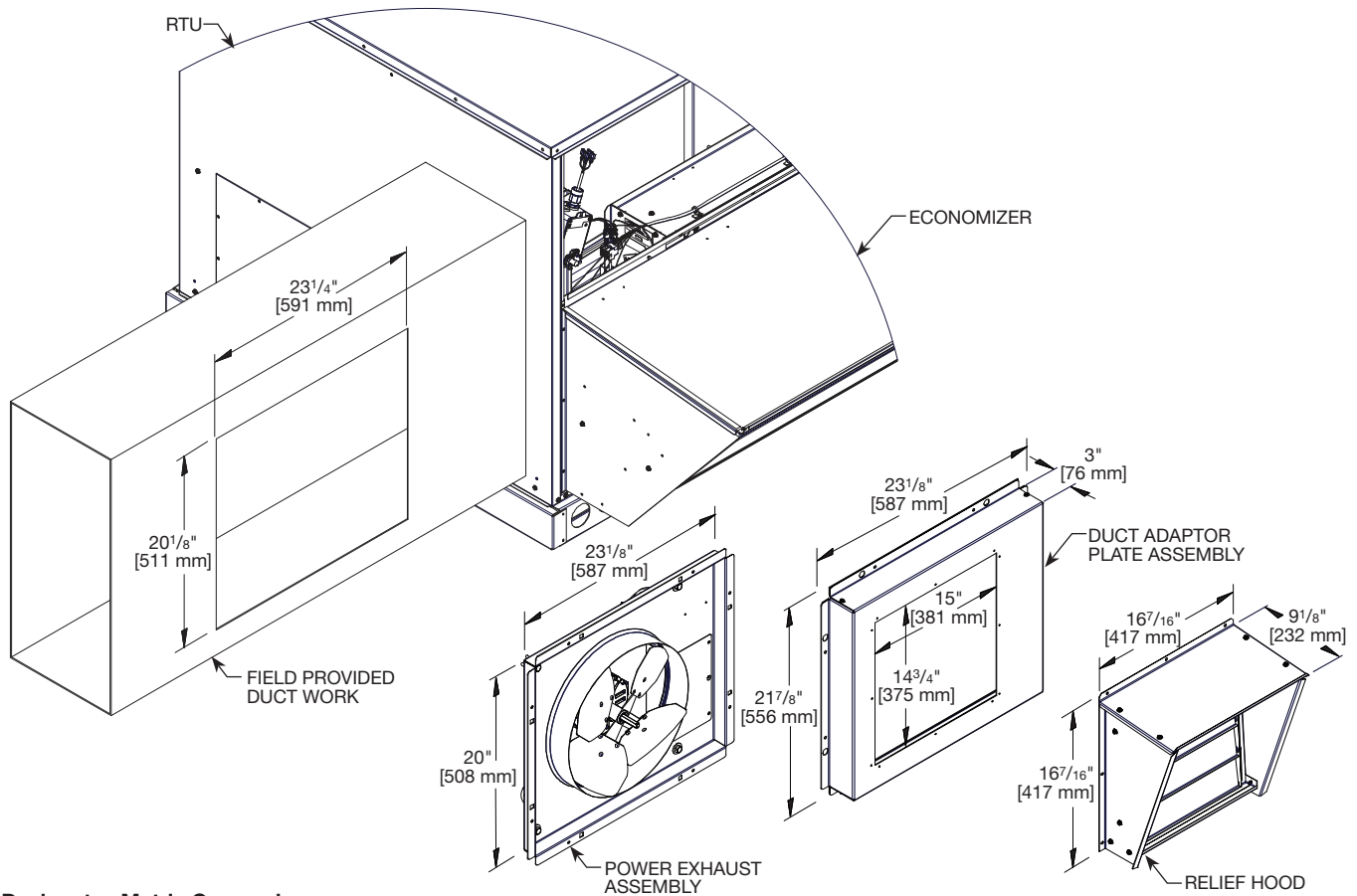

[] Designates Metric Conversions

Model No.	Volt	Phase	Motor				Unit				@ 0.1 CFM
			HP	RPM	LRA	Qty.	Cir. Qty.	FLA	MCA	Fuse Size	
RXXR-RCF03C	208-230	1	1/2	1625	5.86	1	1	2.70	3.38	6	2013
RXXR-RCF03D	460				3.33			1.34	1.68	3	
RXXR-RCF03Y	575				2.52			1.06	1.33	2	

FRESH AIR DAMPER

MOTORIZED DAMPER KIT RXRF-ACB1

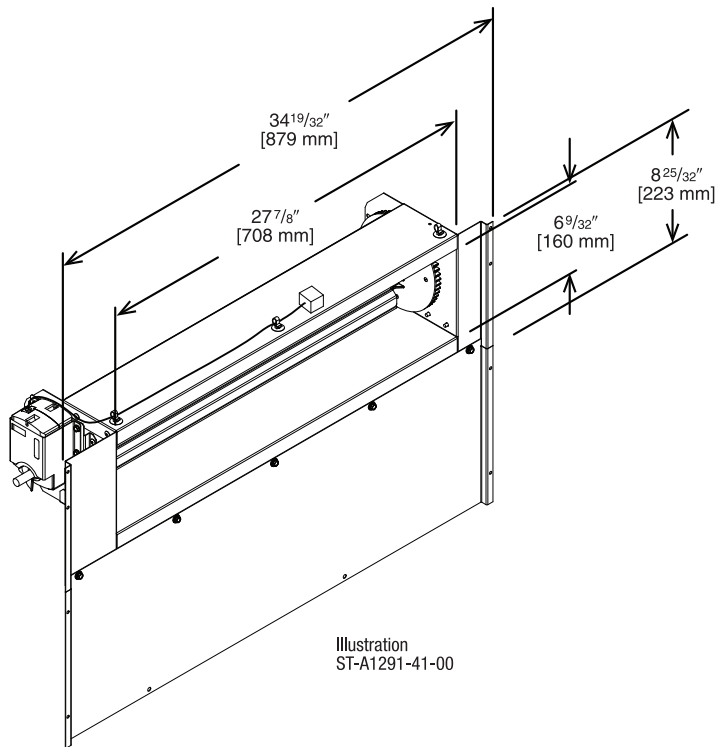

[] Designates Metric Conversions

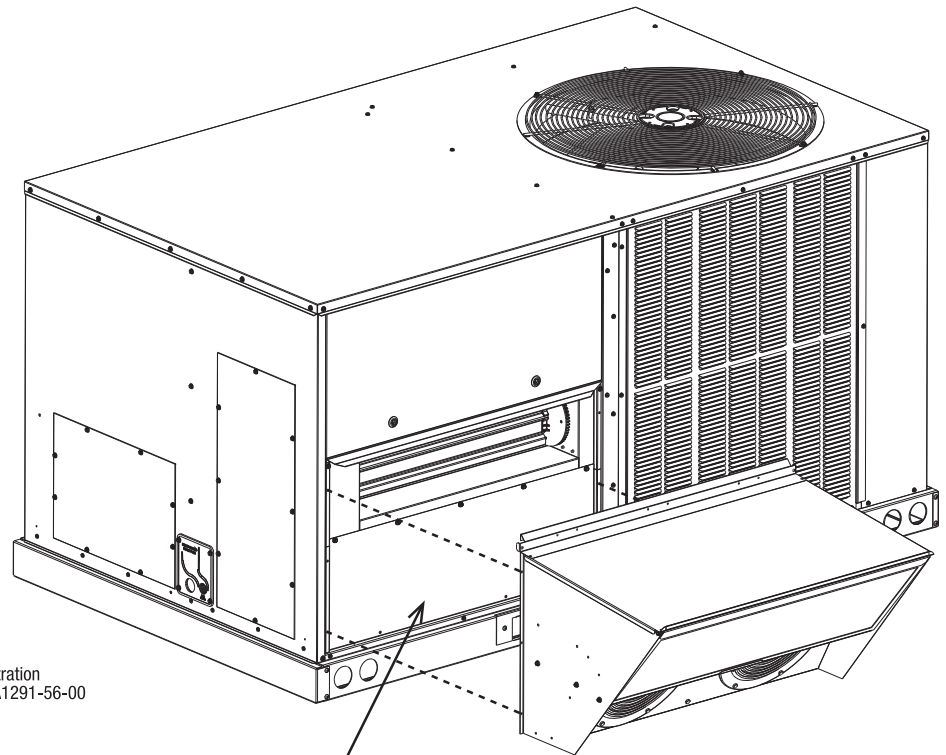

- Features **Siemens** Actuator
- Gear Driven Direct Drive Actuator
- Adjustable to 2 positions
- Slip-In Design for Easy Installation
- Plug-In Polarized 12-pin and 4-pin Electrical Connections
- Pre-Configured—No Field Adjustments Necessary

FRESH AIR DAMPER

MANUAL DAMPER KIT
RXRF-ACA1

DOWNFLOW APPLICATION

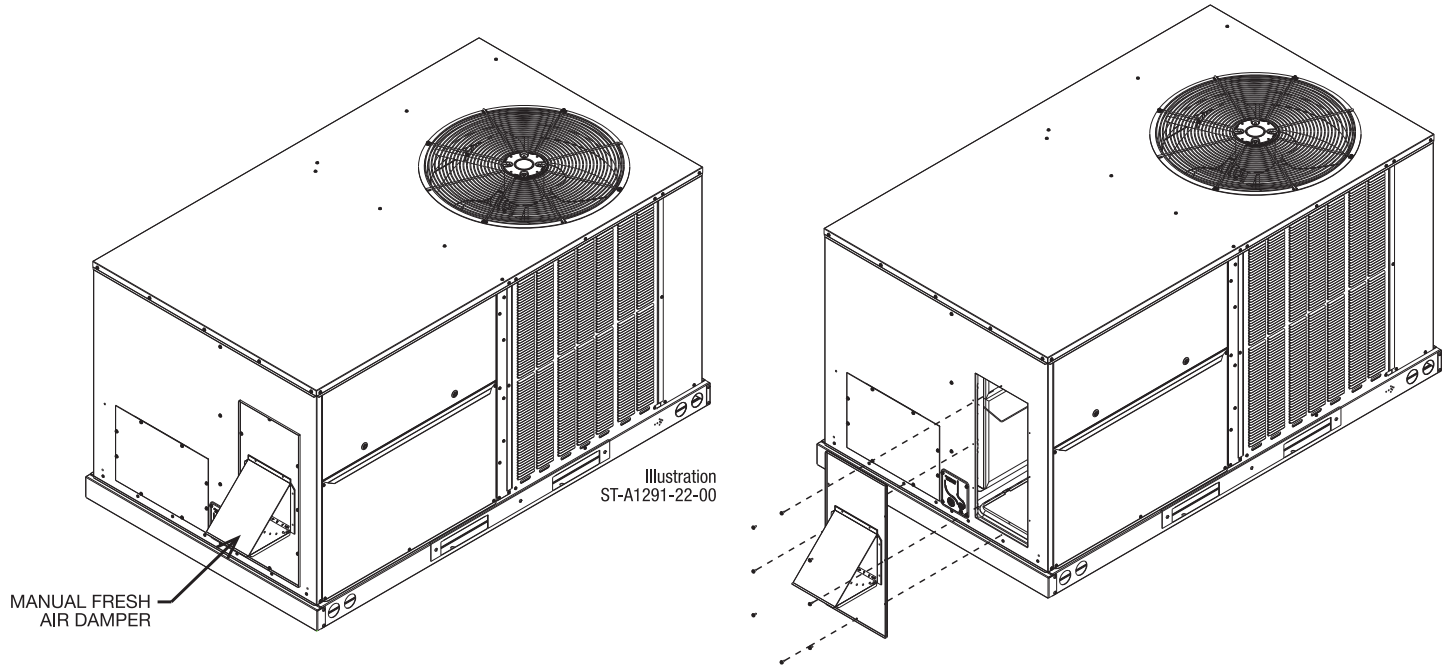

HORIZONTAL APPLICATION

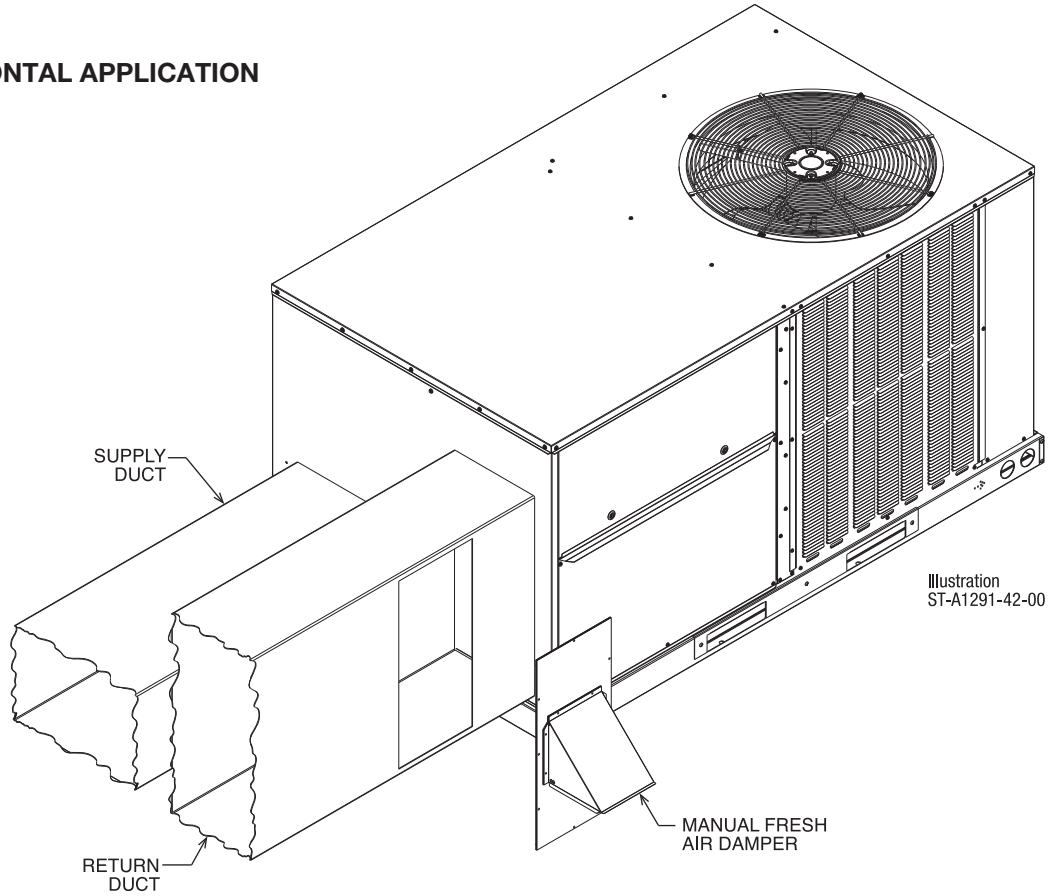

ROOFCURBS (Full Perimeter)

- Russell® By Rheem roofcurb design can be utilized on all 3-5 ton [10.6-17.6 kW] RGEC- models
- Two available heights (14" [356 mm] and 24" [610 mm]) for ALL models
- Quick assembly corners for simple and fast assembly
- Opening provided in bottom pan to match the "Thru the Curb" electrical, gas piping, condensate, connection opening provided on the unit base pan
- 1" [25 mm] x 4" [102 mm] Nailers provided
- Sealing gasket (40' [12.2 m]) provided with Roofcurb
- Packaged for easy field assembly

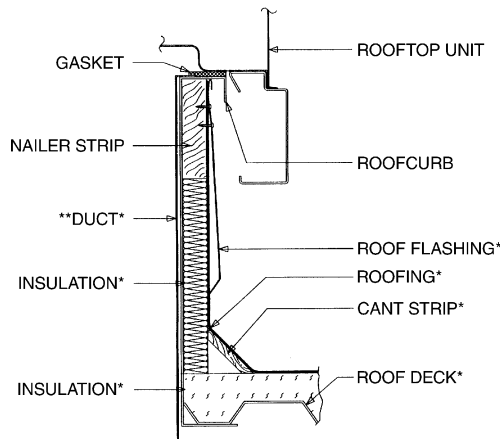

*BY CONTRACTOR
 **FOR INSTALLATION OF DUCT AS SHOWN, USE RECOMMENDED DUCT SIZES FROM ROOFCURB INSTALLATION INSTRUCTIONS. FOR DUCT FLANGE ATTACHMENT TO UNIT, SEE UNIT INSTALLATION INSTRUCTIONS FOR RECOMMENDED DUCT SIZES.

Illustration
ST-A0743-02

View	Roofcurb Model	Height of Curb
A	RXKG-DCC14	14" [356 mm]
A	RXKG-DCC24	24" [610 mm]

ROOFCURB INSTALLATION

VIEW A

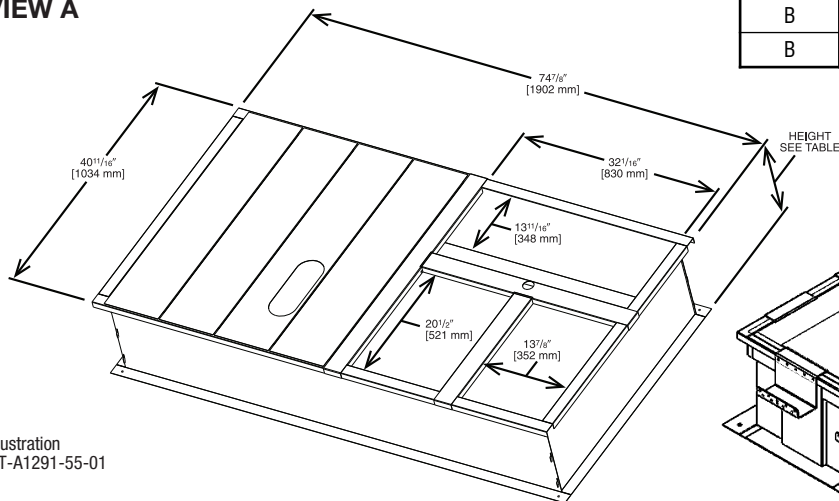
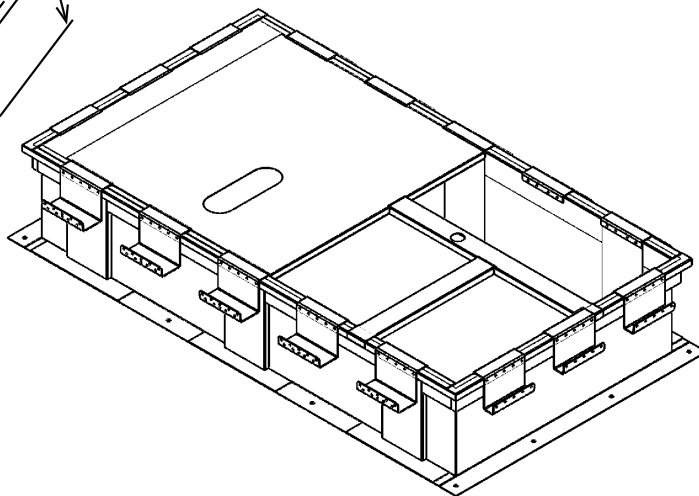

Illustration
ST-A1291-55-01

View	Roofcurb Model	Dimensions
B	RXKG-DC14	74.875" x 40.688" x 14.0"
B	RXKG-DC24	74.875" x 40.688" x 24.0"

WELDED ROOFCURB VIEW B



[] Designates Metric Conversions

• State of Florida Approved: Approval Number FL 26981 for Technical Evaluation Report TER-20-28788 certifies the HVAC Unit and mounting methods for high wind resistance are compliant per Florida Building Code.

FLUE DIVERter

FLUE DIVERter RXX-DEG03

FLUE DIVERter HELPS DIRECT PRODUCTS OF COMBUSTION AWAY FROM FRESH AIR INTAKES. FLUE DIVERter IS COMPATIBLE WITH ALL THREE BTU INPUTS. REFER TO ANSI Z223.1 NATIONAL FUEL GAS CODE FOR APPLICABLE B-VENT DIAMETER (FIELD-SUPPLIED).

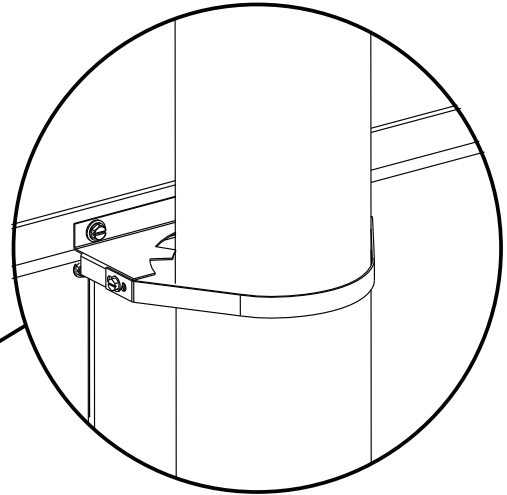
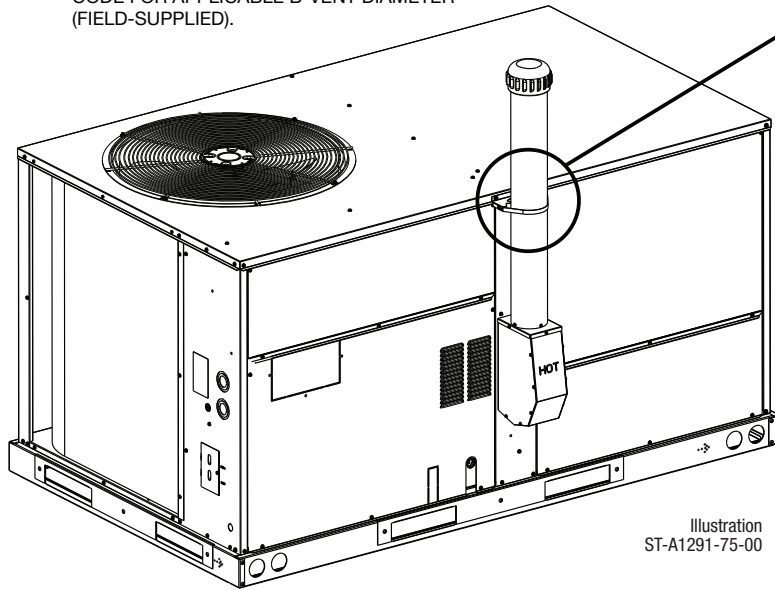

B-VENT SUPPORT BRACKET DETAIL. SHOWN WITH 4-INCH FLUE PIPE.

Illustration
ST-A1291-75-00

ROOFCURB ADAPTERS (CON'T.)

RXXR-DCCAE

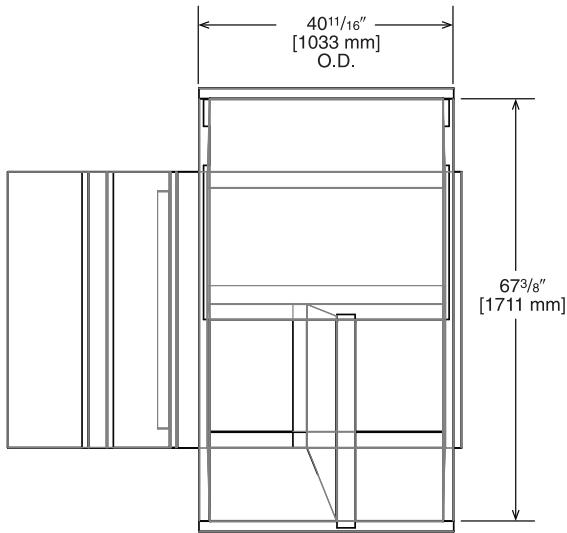

Approximate Static Pressure Drop
@1200 CFM = 0.05" w.g.
@2000 CFM = 0.19" w.g.

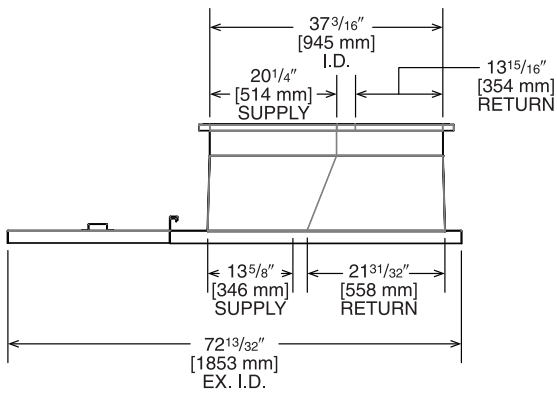
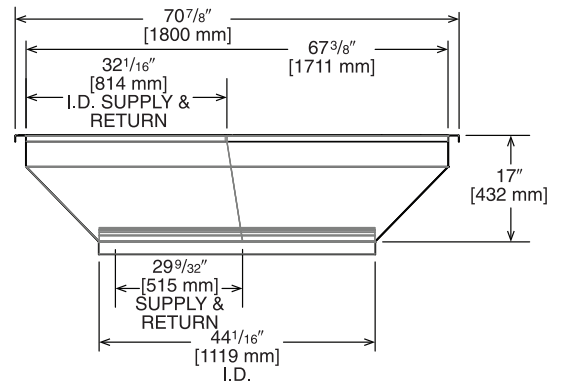
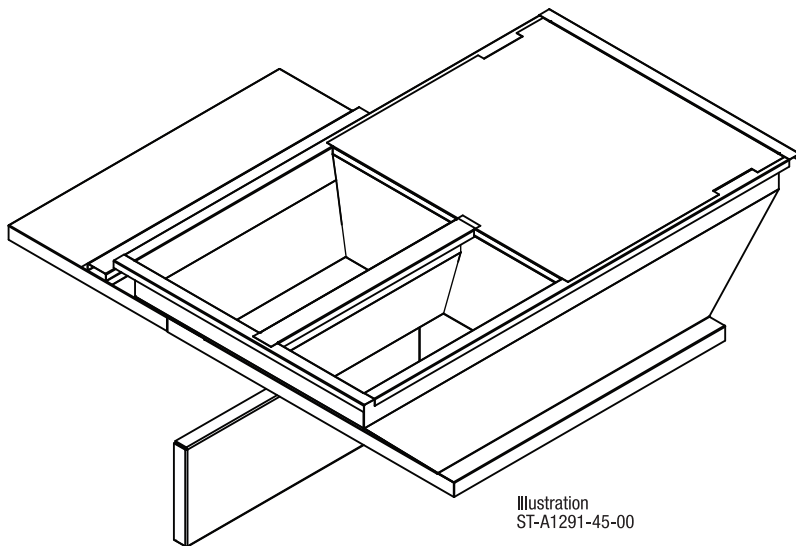

Illustration ST-A1291-44-00



TOP VIEW



[] Designates Metric Conversions

CONCENTRIC DIFFUSER APPLICATION

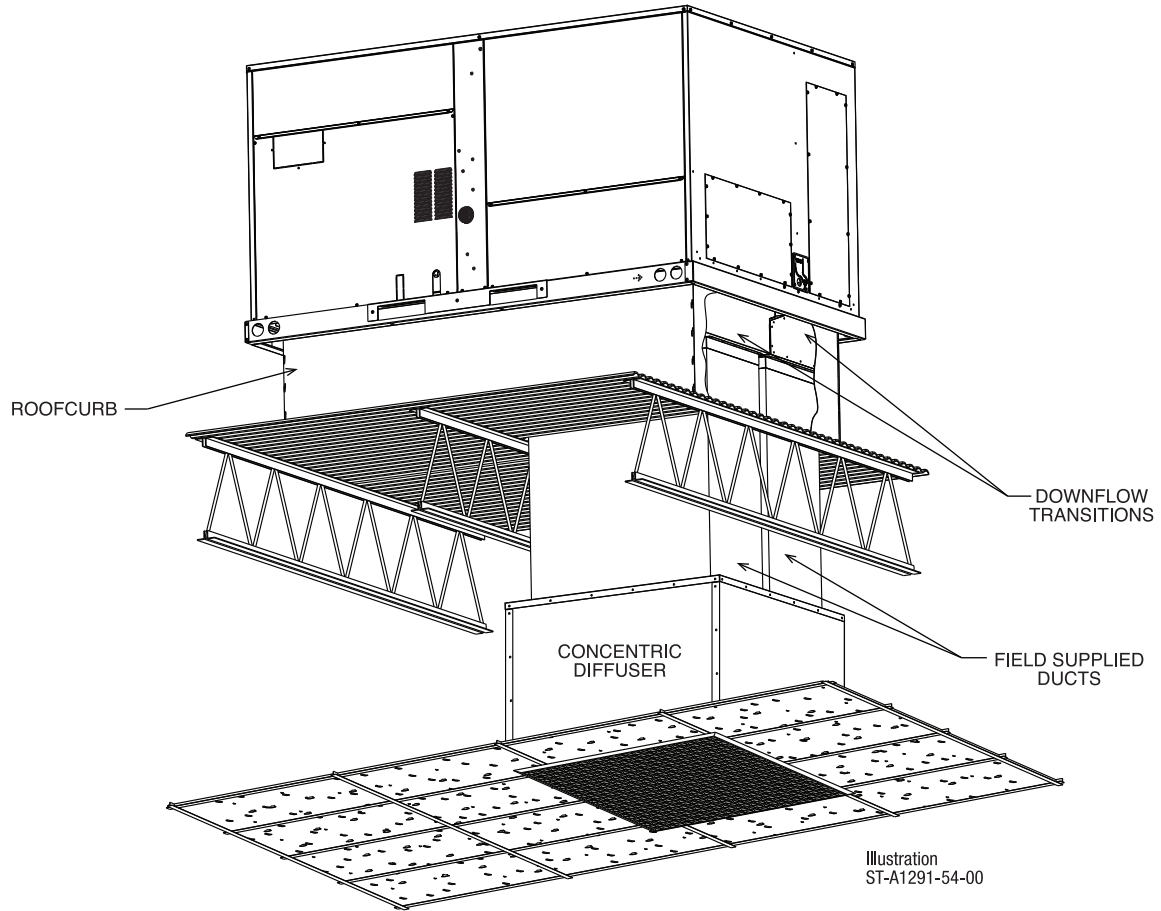

DOWNFLOW TRANSITION DRAWINGS

RXMC-DC01 Concentric Adapter 3 and 4 Ton [10.6 and 14.1 kW] Drop

- Used with AEF1800 or AED1800 Concentric Diffusers

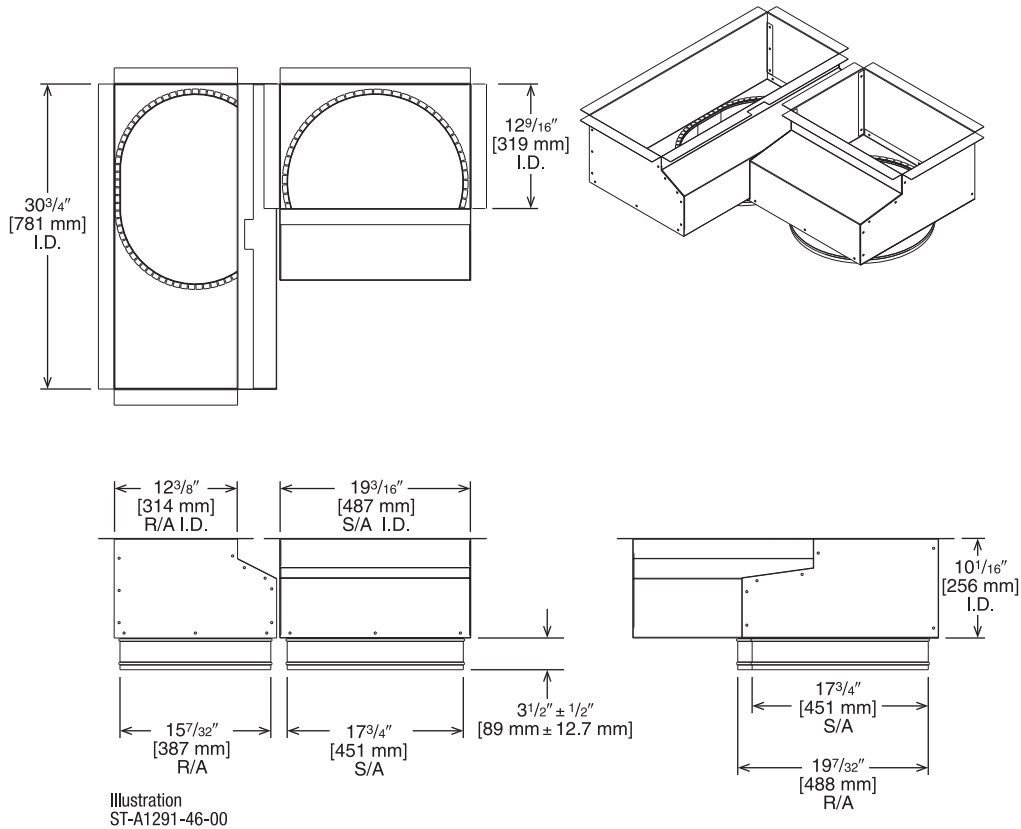

[] Designates Metric Conversions

CONCENTRIC DIFFUSER—STEP DOWN

RXRN-AED1800 (3 and 4 Ton [10.6 and 14.1 kW] Models)

For Use With Downflow Transition (RXMC-DC01) and 18" [457 mm] Round Supply and Return Ducts

- All aluminum diffuser with aluminum return air eggcrate
- Built-in anti-sweat gasket
- Molded fiberglass supports
- Built-in hanging supports
- Diffuser box constructed of sheet metal insulated with 1" [25.4 mm] 1.5 lbs. [.7 kg] duct liner

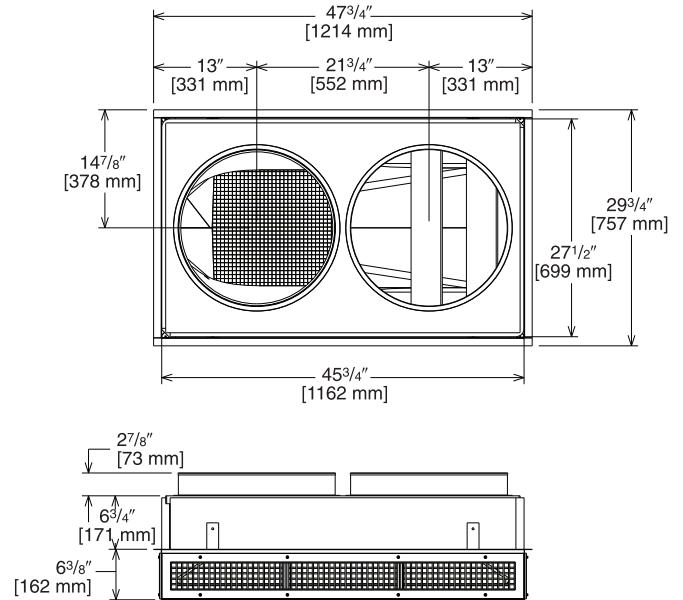
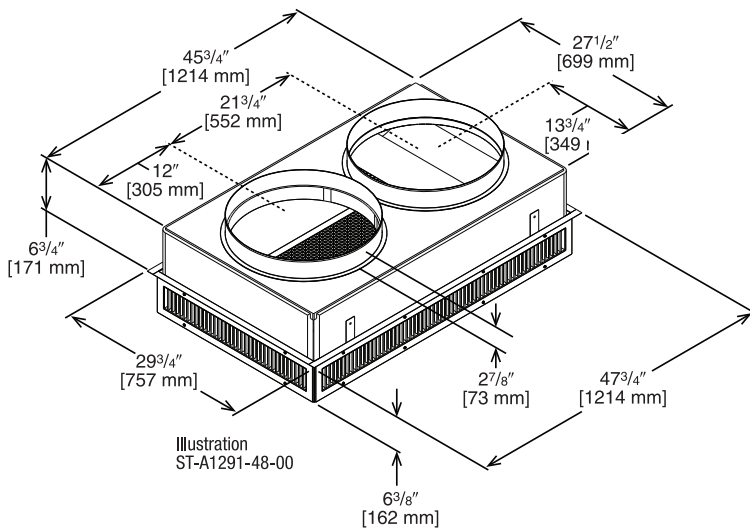

ENGINEERING DATA^①

Model No.	Flow Rate CFM [L/s]	Throw ^{② ③} Feet [m]	Neck Velocity fpm [m/s]	Noise Level ^④ (dbA)
RXRN-AED1800	1000 [472]	9-23 [2.7-7.0]	391 [2.0]	12
	1200 [566]	10-24 [3.0-7.3]	469 [2.4]	15
	1400 [661]	12-26 [3.7-7.9]	547 [2.8]	19
	1600 [755]	13-28 [4.0-8.5]	625 [3.2]	21
	1800 [849]	15-30 [4.6-9.1]	703 [3.6]	26
	2000 [944]	17-32 [5.2-9.8]	781 [4.0]	30
	2400 [1133]	19-34 [5.8-10.4]	859 [5.8]	32

- NOTES:** ① All data is based on the air diffusion council guidelines.
 ② Throw data is based on 75 FPM Terminal Velocities using isothermal air.
 ③ Throw is based on diffuser blades being directed in a straight pattern.
 ④ Actual noise levels may vary due to duct design and do not include transmitted unit noise. Adequate duct attenuation must be provided to reduce sound output from the unit.

[] Designates Metric Conversions

FLUSH MOUNT CONCENTRIC DIFFUSER—FLUSH

RXRN-AEF1800 (3 and 4 Ton [10.6 and 14.1 kW])

For Use With Downflow Transition (RXMC-DC01)
18" [457 mm] Round Supply and Return Ducts

- All aluminum diffuser with aluminum return air eggcrate
- Built-in anti-sweat gasket
- Molded fiberglass supports
- Built-in hanging supports
- Diffuser box constructed of sheet metal insulated with 1" [25.4 mm] 1.5 lbs. [.7 kg] duct liner

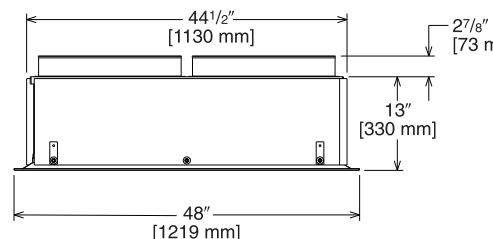
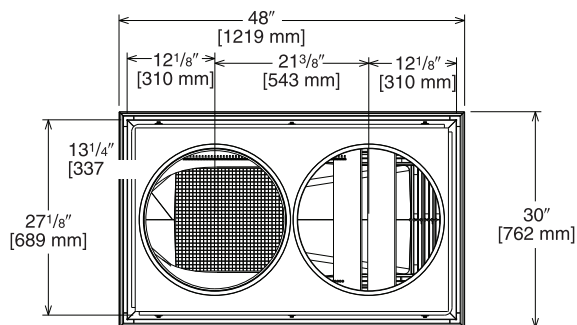
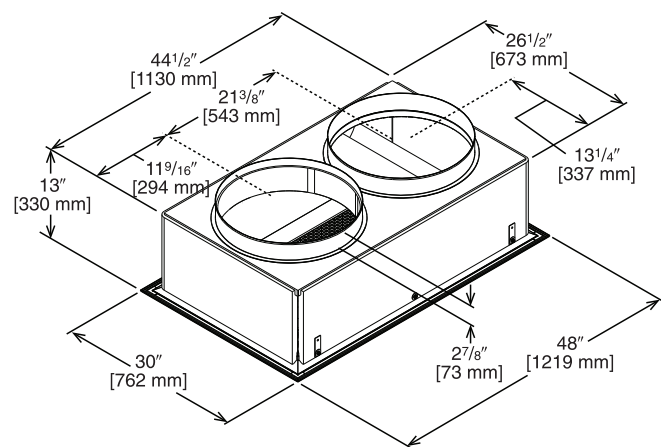

Illustration
ST-A1291-49-00

ENGINEERING DATA^①

Model No.	Flow Rate CFM [L/s]	Throw ^{② ③} Feet [m]	Neck Velocity fpm [m/s]	Noise Level ^④ (dba)
RXRN-AEF1800	1000 [472]	9-12 [2.7-3.7]	663 [3.4]	20
	1200 [566]	12-16 [3.7-4.9]	714 [3.6]	25
	1400 [661]	15-20 [4.6-6.1]	765 [3.9]	30
	1600 [755]	17-23 [5.2-7]	816 [4.1]	30
	1800 [849]	20-26 [6.1-7.9]	867 [4.4]	35
	2000 [944]	22-29 [6.7-8.8]	918 [4.7]	40
	2400 [1133]	25-32 [7.6-9.8]	969 [4.9]	45

NOTES: ① All data is based on the air diffusion council guidelines.

② Throw data is based on 75 FPM Terminal Velocities using isothermal air.

③ Throw is based on diffuser blades being directed in a straight pattern.

④ Actual noise levels may vary due to duct design and do not include transmitted unit noise. Adequate duct attenuation must be provided to reduce sound output from the unit.

[] Designates Metric Conversions

DOWNFLOW TRANSITION DRAWINGS

RXMC-DC02 Concentric Adapter 5 and 6 Ton [17.6 and 21.1 kW] Drop

- Used with AEF2000 or AED2000 Concentric Diffusers

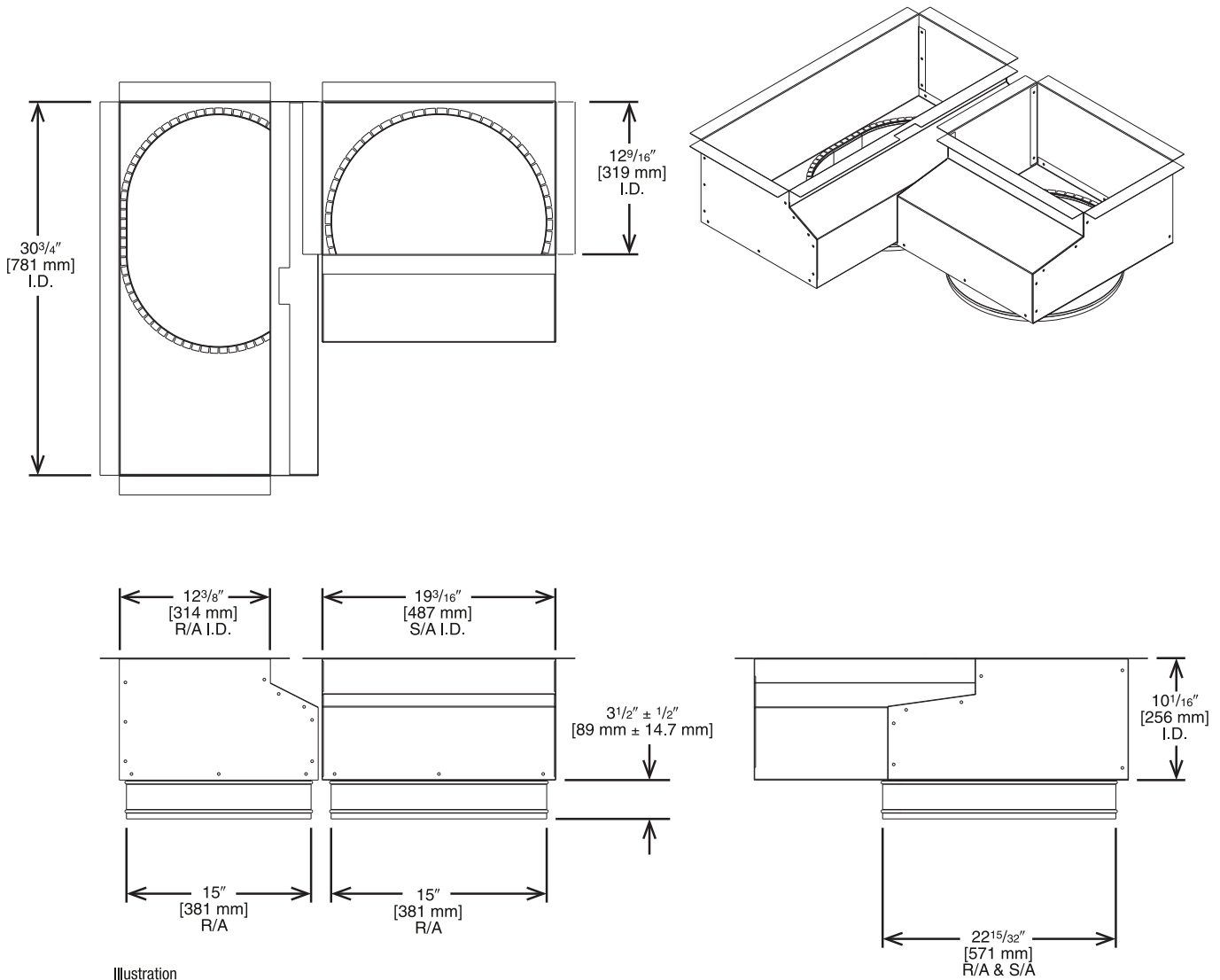

[] Designates Metric Conversions

CONCENTRIC DIFFUSER – STEP DOWN

RXRN-AED2000 (5 Ton [17.6 kW] Models)

For Use With Downflow Transition (RXMC-DC02)
and 20" [508 mm] Round Supply and Return Ducts

- All aluminum diffuser with aluminum return air eggcrate
- Built-in anti-sweat gasket
- Molded fiberglass supports
- Built-in hanging supports
- Diffuser box constructed of sheet metal insulated with 1" [25.4 mm] 1.5 lbs. [.7 kg] duct liner

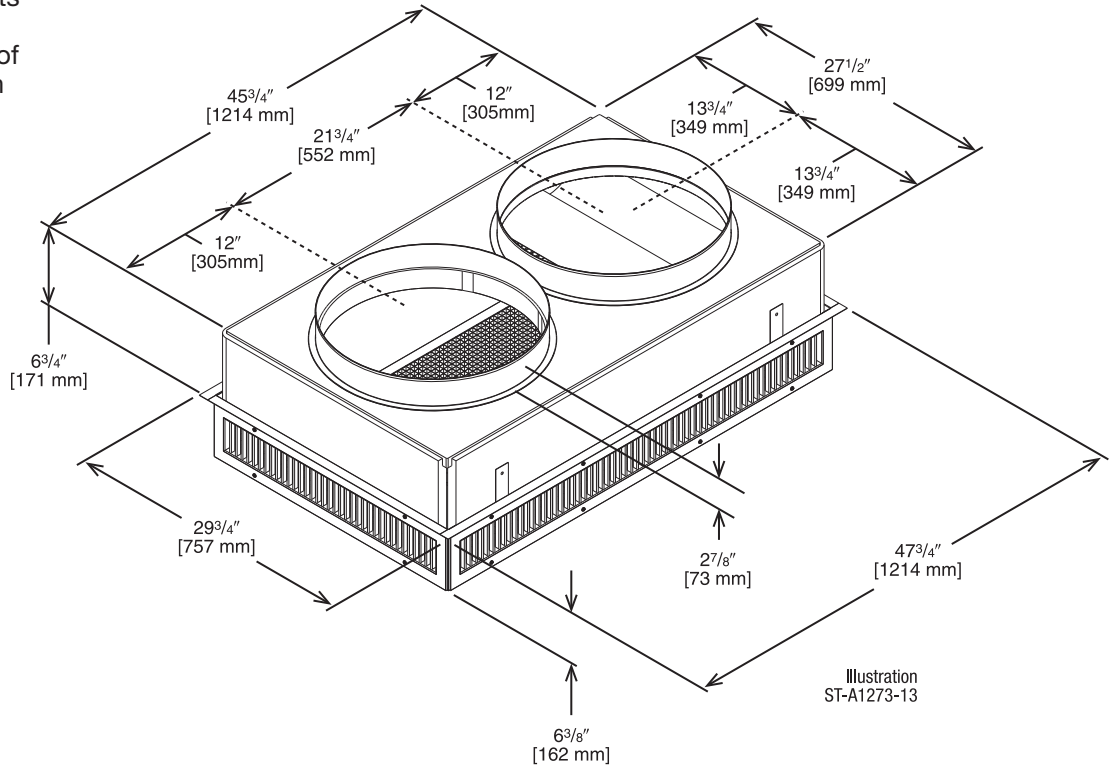

ENGINEERING DATA^①

Model No.	Flow Rate CFM [L/s]	Throw ^{② ③} Feet [m]	Neck Velocity fpm [m/s]	Noise Level ^④ (dB)
RXRN-AED2000	2600 [1222]	22-39 [6.7-11.9]	669 [3.4]	32
	2800 [1316]	23-40 [7.1-12.2]	720 [3.7]	38
	3000 [1410]	25-42 [7.6-12.8]	772 [3.9]	40
	3200 [1504]	26-43 [7.9-13.1]	823 [4.2]	41
	3400 [1598]	27-45 [8.2-13.7]	874 [4.4]	42

- NOTES:** ① All data is based on the air diffusion council guidelines.
 ② Throw data is based on 75 FPM Terminal Velocities using isothermal air.
 ③ Throw is based on diffuser blades being directed in a straight pattern.
 ④ Actual noise levels may vary due to duct design and do not include transmitted unit noise. Adequate duct attenuation must be provided to reduce sound output from the unit.

[] Designates Metric Conversions

Guide Specifications RGEC—036–072

You may copy this document directly into your building specification. This specification is written to comply with the 2016 version of the “master format” as published by the Construction Specification Institute. www.csinet.org.

GAS HEAT PACKAGED ROOFTOP**HVAC Guide Specifications****Size Range: 3 to 6 Nominal Tons**

- 1.00 General
 - A. Outdoor, rooftop mounted, electrically controlled, heating and cooling unit utilizing a(n) hermetic scroll compressor(s) for cooling duty and heat pump for heating duty.
 - B. Factory assembled, single-piece heating and cooling rooftop unit. Contained within the unit enclosure shall be all factory wiring, piping, controls, and special features required prior to field start-up.
 - C. Unit shall use environmentally safe, R-454B refrigerant.
 - D. Unit shall be installed in accordance with the manufacturer’s instructions.
 - E. Unit must be selected and installed in compliance with local, state, and federal codes.
- 1.01 Quality Assurance
 - A. Unit meets ASHRAE 90.1 2022 minimum efficiency requirements.
 - B. Unit shall be rated in accordance with AHRI Standards 210/240 or 340/360 and 10 CFR appendix M1 to subpart B or part 430.
 - C. Unit shall be designed to conform to ASHRAE 15.
 - D. Unit shall be UL-tested and certified in accordance with Standards and UL-listed and certified under Canadian standards as a total package for safety requirements.
 - E. Insulation and adhesive shall meet NFPA 90A requirements for flame spread and smoke generation.
 - F. Unit casing shall be capable of withstanding 1000-hour salt spray exposure per ASTM B117 (scribed specimen).
 - G. Roof curb shall be designed to conform to NRCA Standards.
 - H. Unit shall be subjected to a completely automated run test on the assembly line. The data for each unit will be stored at the factory, and must be available upon request.
 - I. Unit shall be designed in accordance with UL Standard 60335-2-40 4th Edition. including tested to withstand rain.
- 1.02 Manufacturer Qualifications
 - A. Unit shall be designed in accordance with ISO 9001:2015, and shall be manufactured in a facility registered by ISO 9001:2015.
- 1.03 Installer Qualifications
 - A. The installer shall be trained to install and service equipment with A2L refrigerants.
- 1.04 Delivery, Storage, and Handling
 - A. Unit shall be stored and handled per manufacturer’s recommendations.
 - B. Lifted by crane requires either shipping top panel or spreader bars.
 - C. Unit shall only be stored or positioned in the upright position.
- 1.05 Unit Cabinet
 - A. Unit cabinet shall be constructed of galvanized steel.
 - B. Unit cabinet exterior paint shall be: pre-painted steel.
 - C. Evaporator fan compartment interior cabinet insulation shall conform to AHRI Standards 210 or 360 minimum exterior sweat criteria. Interior surfaces shall be insulated with a minimum 1/2-in. thick, 1.6 lb density, flexible fiberglass insulation, foil faced on the air side. Aluminum foil-faced fiberglass insulation shall be used in the gas heat compartment.
 - D. Base of unit shall have a location for thru-the-base gas and electrical connections standard.
 - E. Base Rail
 - i. Unit shall have base rails on a minimum of 4 sides.
 - ii. Holes shall be provided in the base rails for rigging shackles to facilitate maneuvering and overhead rigging.
 - iii. Holes shall be provided in the base rail for moving the rooftop for fork truck.
 - iv. Base rail shall be a minimum of 14 gauge thickness.
 - F. Condensate pan and connections:
 - i. Shall be a sloped condensate drain pan made of a non-corrosive material and be removable for cleaning.
 - ii. Shall comply with ASHRAE Standard 62.
 - iii. Shall use a 3/4" NPT drain connection, possible either through the bottom or side of the drain pan. Connection shall be made per manufacturer’s recommendations.
 - iv. Shall be able to be easily removed.

- G. Top panel:
 - i. Shall be a single piece top panel over indoor section.
- H. Gas Connections
 - A. All gas piping connecting to unit gas valve shall enter the unit cabinet at a single location on side of unit (horizontal plane).
 - B. Thru-the-base-capability
 - i. Standard unit shall have a thru-the-base gas-line locations using a continuous raised, flange around opening in the basepan.
 - ii. No basepan penetration, other than those authorized by the manufacturer, is permitted.
- I. Electrical Connections
 - A. All unit power wiring shall enter unit cabinet a a single, factory-prepared, continuous raised flange opening in the basepan.
 - B. Thru-the-base capability
 - i. Standard unit shall have a thru-the-base electrical location(s) using a raised, continuous raised flange opening in the basepan.
 - ii. No basepan penetration, other than those authorized by the manufacturer, is permitted.
- J. Component access panels (standard)
 - A. Cabinet panels shall be easily opened for servicing.
 - B. Panels covering control box, indoor fan, indoor fan motor, gas components (where applicable), and filters shall have hinges with 1/4 turn fasteners on units with factory-installed hinged option.
 - C. 1/4 turn fasteners shall be permanently attached.
- 1.06 Operating Characteristics
 - A. Unit shall be capable of starting and running at 115°F (46°C) ambient outdoor temperature, meeting maximum load criteria of AHRI Standard 210/240 or 340/360 at ± 10% voltage.
 - B. Compressor with standard controls shall be capable of operation down to 50°F (10°C), ambient outdoor temperatures. Low ambient accessory kit is necessary if mechanically cooling at ambient temperatures to 0°F (-17.7°C).
 - C. Unit shall discharge supply air vertically or horizontally as shown on contract drawings.
 - D. Unit shall be factory configured for vertical supply & return configurations.
 - E. Unit shall be field convertible from vertical to horizontal configuration.
- 1.07 Electrical Requirements
 - A. Main power supply voltage, phase, and frequency must match those required by the manufacturer.
- 1.08 Evaporator fan compartment:
 - A. Interior cabinet surfaces shall be insulated with a minimum 1/2-in. thick, minimum 1.6 LB density, flexible fiberglass insulation bonded with foil face on the air side.
 - B. Insulation and adhesive shall meet NFPA 90A requirements for flame spread and smoke generation.
 - C. Insulation shall also be mechanically fastened with welded pin and retainer washer.
- 1.09 Thermostats
 - A. Thermostat must
 - i. Energize both “W” and “G” when calling for heat.
 - ii. Have capability to energize 1 stage of cooling, and at least 1 stage of heating.
 - iii. Include capability for occupancy scheduling.
- 1.10 Electronic Control System for HVAC
 - A. Shall be complete with self-contained low-voltage control circuit protected by a fuse on the 24-V transformer side.
 - B. Shall utilize color-coded wiring.
 - C. Unit shall include a minimum of one 8-pin screw terminal connection board for connection of control wiring.
 - D. The heat exchanger shall be controlled by the Core Command microprocessor. See heat exchanger section of this specification.
- 1.10.01 Safeties:
 - A. Compressor over-temperature, over current.
 - B. Low-pressure switch.
 - i. Units shall have low pressure, loss of charge automatic reset device that will shut off compressor when tripped.
 - C. High-pressure switch.
 - i. Unit shall be equipped with high pressure switch device that will shut off compressor when tripped.
 - D. Automatic reset, motor thermal overload protector.

- E. The unit must be permanently grounded.
- F. Components are not compatible between different refrigerants. Do not use R-410A service equipment or components on R-454B equipment. System or part failure could occur.
- G. Heating section shall be provided with the following minimum protections:
 - i. High-temperature limit switches.
 - ii. Induced draft motor pressure switch.
 - iii. Flame rollout switch.
 - iv. Flame proving controls.
- 1.11 Standard Filter Section
 - A. Shall consist of factory-installed, low velocity, throwaway 2-in. thick fiberglass filters of commercially available sizes.
 - B. Unit will accept both 2-in. and 4-in. filters.
 - C. Filter face velocity shall not exceed 365 fpm at nominal airflows.
 - D. Filters shall be accessible through an access panel with “no-tool” removal as described in the unit cabinet section of the specification.
 - E. Filters access is specified in the unit cabinet section of this specification.
 - F. Filters shall be held in place by metal rods, facilitating easy removal and installation.
- 1.12 Coils
 - A. Standard Aluminum/MicroChannel Coils:
 - i. Standard evaporator and condenser coils shall be aluminum.
 - ii. Evaporator and condenser coils shall be leak tested to 150 psig, pressure tested to 400 psig, and qualified to burst test at 2,200 psi.
- 1.13 Refrigerant Components
 - A. Refrigerant circuit shall include the following control, safety, and maintenance features:
 - i. TXV metering system shall prevent mal-distribution of two-phase refrigerant.
 - ii. Refrigerant filter drier.
 - iii. Service gauge connections on suction and discharge lines.
 - iv. External pressure gauge ports access shall be located in front exterior of cabinet.
 - B. Compressors
 - i. Unit shall use one fully hermetic scroll compressor.
 - ii. 3-5 ton YB units include one single-stage compressor.
 - iii. 6 ton YB units include one two-stage compressor.
 - iv. Compressor motors shall be cooled by refrigerant gas passing through motor windings.
 - v. Compressors shall be internally protected from high discharge temperature conditions.
 - vi. Compressors shall be protected from an over-temperature and over-amperage conditions by an internal, motor overload device.
 - vii. Compressor shall be factory mounted on rubber grommets.
 - viii. Compressor motors shall have internal line break thermal and current overload protection.
 - ix. Crankcase heaters shall not be required for normal operating range.
 - x. Compressor shall have molded electrical plug.
- 1.14 Evaporator Fan and Motor
 - A. Evaporator fan motor:
 - i. Shall have permanently lubricated bearings.
 - ii. Shall have inherent automatic-reset thermal overload protection.
 - B. Direct Drive Evaporator Fan:
 - i. Direct drive ECM technology with (5) dedicated speed selections as follows: fan, low, high, AC low static, AC high static.
 - ii. Blower fan shall be double-inlet type with forward-curved blades.
 - iii. Shall be constructed from steel with a corrosion resistant finish and dynamically balanced.
- 1.15 Condenser Fans and Motors
 - A. Condenser Fan Motors:
 - i. Shall be a totally enclosed motor.
 - ii. Shall use permanently lubricated bearings.
 - iii. Shall have inherent thermal overload protection with an automatic reset feature.
 - iv. Shall use a shaft-down design. Shaft-up designs including those with “rain-slinger devices” shall not be allowed.

- B. Condenser Fans shall:
 - i. Shall be a direct-driven propeller type fan
 - ii. Shall have blades riveted to corrosion-resistant steel spiders and shall be dynamically balanced.
- 1.16 Gas Heat Compartment:
 - A. Aluminum foil-faced fiberglass insulation shall be used.
 - B. Insulation and adhesives shall meet NFPA 90A requirements for flame spread and smoke generation.
 - C. Insulation shall also be mechanically fastened with welded pin and retainer washer.
- 1.17 Gas Heat
 - A. Heat exchanger shall be an induced draft design. Positive pressure heat exchanger designs shall not be allowed.
 - B. Shall incorporate a direct-spark ignition system and redundant main gas valve.
 - C. Heat exchanger design shall allow combustion process condensate to gravity drain; maintenance to drain the gas heat exchanger shall not be required.
 - D. Gas supply pressure at the inlet to the rooftop unit gas valve must match that required by the manufacturer.
 - E. The heat exchanger shall be controlled by the CoreCommand microprocessor.
 - i. The CoreCommand board shall notify users of fault using two 7 segment displays.
 - F. Standard Heat Exchanger construction
 - i. Heat exchanger shall be of the tubular-section type constructed of a minimum of 20-gauge steel coated with a nominal 1.2 mil aluminum-silicone alloy for corrosion resistance.
 - ii. Burners shall be of the in-shot type constructed of aluminum-coated steel.
 - iii. Burners shall incorporate orifice for rated heat output up to 2,000 ft. (610m) elevation with a gas heating valve of 1050. Alternate orifices may be required depending on local gas heating valves and elevations.
 - iv. Each heat exchanger tube shall contain restrictions similar to dimples for increased heating effectiveness.
 - G. Optional Stainless Steel Heat Exchanger construction
 - i. Use energy saving, direct-spark ignition system.
 - ii. Use a redundant main gas valve.
 - iii. Burners shall be of the in-shot type constructed of aluminum-coated steel.
 - iv. All gas piping shall enter the unit cabinet at a single location on side of unit (horizontal plane).
 - v. The optional stainless steel heat exchanger shall be of the tubular-section type, constructed of a minimum of 20-gauge type 409 stainless steel.
 - vi. Type 409 stainless steel shall be used in heat exchanger tubes.
 - H. Induced draft combustion motor and blower
 - i. Shall be a direct-drive, single inlet, forward-curved centrifugal type.
 - ii. Shall be made from steel with a corrosion-resistant finish.
 - iii. Shall be permanently lubricated sealed bearings.
 - iv. Shall have inherent thermal overload protection.
 - v. Shall have an automatic reset feature.
- 1.18 Special Features
 - A. Integrated Economizers:
 - i. Integrated, parallel modulating blade design type capable of simultaneous economizer and compressor operation.
 - ii. Independent modules for vertical or horizontal return configurations shall be available. Vertical return modules shall be available as a factory-installed option.
 - iii. Damper blades shall be galvanized steel. Plastic or composite blades on intake or return shall not be acceptable.
 - iv. Shall include all hardware and controls to provide free cooling with outdoor air when temperature and/or humidity are below setpoints.
 - v. Shall be equipped with driven dampers for both the outdoor ventilation air and the return air for positive air stream control.
 - vi. Shall be equipped with low-leakage dampers, not to exceed 2% leakage at 1 in. wg pressure differential.
 - vii. Shall be capable of introducing up to 100% outdoor air.
 - viii. Shall be equipped with a barometric relief damper capable of relieving up to 100% return air.
 - ix. Shall be designed to close damper(s) during loss-of-power situations with spring return built into motor.
 - x. Enthalpy sensor shall be provided as standard. Outdoor air sensor set point shall be adjustable and shall range from 40 to 100°F / 4 to 38°C. Additional sensor options shall be available as accessories.

- xi. The economizer controller shall also provide control of an accessory power exhaust unit function. Factory set at 70%, with a range of 0% to 100%.
 - xii. The economizer shall maintain minimum airflow into the building during occupied period and provide design ventilation rate for full occupancy. A remote potentiometer may be used to override the damper set point.
 - xiii. Dampers shall be completely closed when the unit is in the unoccupied mode.
 - xiv. Economizer controller shall accept a 2-10Vdc CO2 sensor input for IAQ/DCV control. In this mode, dampers shall modulate the outdoor-air damper to provide ventilation based on the sensor input.
 - xv. Economizer controller shall provide indications when in free cooling mode, in the DCV mode, or the exhaust fan contact is closed.
 - xvi. Economizer wire harness will have provision for smoke detector.
- B. Manual damper
- i. Manual damper package shall consist of damper, air inlet screen, and rain hood which can be preset to admit up to 50% outdoor air for year round ventilation.
- C. Liquid Propane (LP) Conversion Kit (sold separately)
- i. Kit shall contain all the necessary hardware and instructions to convert a standard natural gas unit for use with liquefied propane, up to 2000 ft (610m) elevation.
- D. Condenser Coil Hail Guard Assembly
- i. Shall protect against damage from hail.
 - ii. Shall be louvered style.
- D. Unit-Mounted, Non-Fused Disconnect Switch:
- i. Switch shall be factory-installed, internally mounted.
 - ii. National Electric Code (NEC) and UL approved non-fused switch shall provide unit power shutoff.
 - iii. Shall be accessible from outside the unit.
 - iv. Shall provide local shutdown and lockout capability.
- E. Convenience Outlet:
- i. Non-Powered convenience outlet.
 - ii. Outlet shall be powered from a separate 115-120v power source.
 - iii. A transformer shall not be included.
 - iv. Outlet shall be field-installed and internally mounted with easily accessible 115-v female receptacle.
 - v. Outlet shall include 15 amp GFI receptacle with independent fuse protection.
 - vi. Outlet shall be accessible from outside the unit.
- F. Flue
- i. Flue Discharge shall direct unit exhaust horizontally and have the capability of being directed vertically.
- G. Propeller Power Exhaust:
- i. Power exhaust shall be used in conjunction with an integrated economizer.
 - ii. Independent modules for vertical or horizontal return configurations shall be available.
 - iii. Horizontal power exhaust is shall be mounted in return ductwork.
 - iv. Power exhaust shall be controlled by economizer controller operation. Exhaust fans shall be energized when dampers open past the 0-100% adjustable setpoint on the economizer control.
- G. Roof Curbs (Vertical):
- i. Formed galvanized steel with wood nailer strip and shall be capable of supporting entire unit weight.
 - ii. Permits installation and securing of ductwork to curb prior to mounting unit on the curb.
- H. Return Air Enthalpy Sensor:
- i. The return air enthalpy sensor shall be used in conjunction with an outdoor air enthalpy sensor to provide differential enthalpy control.
- I. Indoor Air Quality (CO2) Sensor:
- i. Shall be able to provide demand ventilation indoor air quality (IAQ) control.
 - ii. The IAQ sensor shall be available in duct mount, wall mount, or wall mount with LED display. The set point shall have adjustment capability.
- J. Smoke detectors:
- i. Shall be a Four-Wire Controller and Detector.
 - ii. Shall be environmental compensated with differential sensing for reliable, stable, and drift-free sensitivity.
 - iii. Shall use magnet-activated test/reset sensor switches.
 - iv. Shall have tool-less connection terminal access.

- v. Shall have a recessed momentary switch for testing and resetting the detector.
- vi. Controller shall include:
 - a. One set of normally open alarm initiation contacts for connection to an initiating device circuit on a fire alarm control panel
 - b. Two Form-C auxiliary alarm relays for interface with rooftop unit or other equipment.
 - c. One Form-C supervision (trouble) relay to control the operation of the Trouble LED on a remote test/reset station.
 - d. Capable of direct connection to two individual detector modules.
 - e. Can be wired to up to 14 other duct smoke detectors for multiple fan shutdown applications.
- K. Barometric relief
 - i. Shall include damper, seals, hardware, and hoods to relieve excess building pressure.
 - ii. Damper shall gravity-close upon shutdown.
- L. Time Guard
 - i. Shall prevent compressor short cycling by providing a 5-minute delay (± 2 minutes) before restarting a compressor after shutdown for any reason.
 - ii. One device shall be required per compressor.

BEFORE PURCHASING THIS APPLIANCE, READ IMPORTANT ENERGY COST AND EFFICIENCY INFORMATION AVAILABLE FROM YOUR RETAILER.

GENERAL TERMS OF LIMITED WARRANTY*

Russell® By Rheem will furnish a replacement for any part of this product which fails in normal use and service within the applicable periods stated, in accordance with the terms of the limited warranty.

Compressor

Commercial ApplicationsFive (5) Years
Residential Applications
(3 to 5 ton models only)Ten (10) Years

Parts

Commercial ApplicationsOne (1) Year
Residential Applications (Conditional)Ten (10) Years

Standard Heat Exchanger

Commercial ApplicationsTen (10) Years
Residential Applications
(3 to 5 ton models only)Ten (10) Years

Stainless Steel Heat Exchanger

Commercial ApplicationsTwenty (20) Years
Residential Applications
(3 to 5 ton models only)Twenty (20) Years

***For complete details of the Limited and Conditional Warranties, including applicable terms and conditions, contact your local contractor or the Manufacturer for a copy of the product warranty certificate.**

Trademarks are property of their respective owners.

In keeping with its policy of continuous progress and product improvement, Russell by Rheem reserves the right to make changes without notice.



Russell® By Rheem

5600 Old Greenwood Road, Fort Smith, AR 72908

Before proceeding with installation, refer to installation instructions packaged with each model, as well as complying with all Federal, State, Provincial, and Local codes, regulations, and practices.