



Packaged Heat Pump
RHPD Series



Commercial Renaissance™ Line Achiever® Series Packaged Heat Pumps



RHPD Series

Efficiencies up to: 11.0 EER, 14.1 IEER & 3.4 COP

Nominal Sizes: 7.5 & 10 Tons [26.4 & 35.2 kW]

Cooling Capacities: 86k Btu/h [25.2 kW] & 114k Btu/h [33.4 kW]

Refrigerant Type: R-454B

ASHRAE 90.1 2022 Compliant Models



RELY ON RUUD.™

FORM NO. P22-851



TABLE OF CONTENTS

Unit Features and Benefits.....	3-10
Model Number Identification	11
Options	12
Selection Procedure	13
General Data	14-18
General Data Notes	19
Gross Systems Performance Data.....	20-25
Airflow Performance Data	26-37
Electrical Data	38-40
Electric Heater Kits.....	41-45
Dimensional Data	46-49
Field-Installed Accessories	50-75
Guide Specifications	76-82
Limited Warranty	83



RHPDYB STANDARD FEATURES INCLUDE:

- Factory charged with R-454B refrigerant
- Factory installed refrigerant leak detection system
- Wired and run tested
- Scroll compressors with internal line break overload and high-pressure protection
- Two stages of cooling
- Convertible airflow – vertical down flow or horizontal side flow
- Forkable base rails for easy handling and lifting
- Cooling operation up to 125°F ambient
- MicroChannel evaporator and condenser coil
- PlusOne® ServiceSmart package includes:
Qwik-Change Flex-Fit Rack
Qwik-Slide Blower Assembly
Qwik-Clean Drain Pan
- Overflow condensate sensor
- PlusOne® Diagnostics with Dual 7-Segment LED Display to meet code compliance
- One-piece top cover and base pan with drawn supply and return opening
- Two-piece control door
- ¼ turn fasteners on filter access door
- Color-coded and labeled wiring
- External lockable gauge ports
- TXV refrigerant metering system
- Solid-core liquid line filter drier
- High-pressure and low-pressure/loss of charge protection with built in Smart Logic
- Insulation encapsulated throughout entire unit
- High performance belt drive motor with variable pitch pulleys and quick adjust belt system
- Blower with Variable Frequency Drive (VFD) control is standard
- Industry standard footprint and matching connections
- MERV 8 & MERV 13 filters are available as an accessory.



Designing for Sustainability with Low GWP: For 2025, the Environmental Protection Agency (EPA) has set a global warming potential (GWP) limit of 700 for refrigerant used in heating and cooling systems. This new requirement will result in a 78%¹ lower GWP than previous-generation refrigerants — with only minimal changes to system installation. For us, this is another step toward our continued sustainability goal of reducing greenhouse gas emissions, while still delivering an exceptional level of energy efficient, dependable comfort.

¹When comparing the GWP of R-454B to R-410A refrigerant.

FACTORY-INSTALLED OPTIONS:

- Louvered panels
- Hinged access doors
- Low ambient/freeze stat
- Non-powered convenience outlet
- Vertical Economizer (Title 24 and ASHRAE 90.1 2022 compliant)
- Supply and return smoke detector
- ElectroFin® E-Coat for Microchannel Condenser Coil
- ClearControl™ Direct Digital Control (DDC)
- Comfort Alert® Phase-monitor Protection

FIELD-INSTALLED ACCESSORY EQUIPMENT:

Accessory	Model Number	Factory Installation Available?
Economizers		
DDC Economizer with Single Enthalpy (Downflow) <i>MicroMetl Economizer with Honeywell Controller</i>	RXRD-01MDDBM3	No
DDC Economizer with Single Enthalpy (Horizontal) <i>MicroMetl Economizer with Honeywell Controller</i>	RXRD-01MDHBM3	No
Non-DDC Economizer with No Controls (Downflow) <i>MicroMetl Economizer, Belimo Actuator</i>	RXRD-31MDDAM3	No
Non-DDC Economizer with Single Enthalpy (Downflow) <i>MicroMetl Economizer with Siemens Controls</i>	RXRD-11MDDAM3	Yes
Non-DDC Economizer with Single Enthalpy (Downflow) <i>Ruskin Rooftop Systems Economizer with RRS Basic Controller</i>	RXRD-41MDDAM3	Yes
Non-DDC Economizer with Single Enthalpy (Downflow) <i>Ruskin Rooftop System Economizer with Siemens Controller</i>	RXRD-51MDDAM3	Yes
Non-DDC Economizer with Single Enthalpy (Horizontal) <i>MicroMetl Economizer with Siemens Controls</i>	RXRD-11MDHAM3	No
Non-DDC Economizer with Single Enthalpy (Horizontal) <i>Ruskin Rooftop Systems Economizer with RRS Basic Controller</i>	RXRD-41MDHAM3	No
Non-DDC Economizer with Single Enthalpy (Horizontal) <i>Ruskin Rooftop System Economizer with Siemens Controller</i>	RXRD-51MDHAM3	No
Economizer Universal DDC Interface Kit	RXRX-DDC01	Yes

FIELD-INSTALLED ACCESSORY EQUIPMENT (CONTINUED):

Accessory	Model Number	Factory Installation Available?
Comfort Alert ¹ (3 Phase) DDC	RXR-AXZ01	Yes
Comfort Alert ¹ (3 Phase) Non-DDC	RXR-AXZ02	Yes
Communication Card, BACnet	RXR-AY01	No
Communication Card, LonWorks	RXR-AY02	No
Concentric Adapter 7.5/8.5 Ton Drop	RXMC-DD01	No
Concentric Adapter 10 Ton Drop	RXMC-DD02	No
Concentric Diffuser 7.5/8.5 Ton Drop	RXR-AED2000	No
Concentric Diffuser 10.0 Ton Drop	RXR-AED3415	No
Concentric Diffuser 7.5/8.5 Ton Flush	RXR-AEF2000	No
Concentric Diffuser 10.0 Ton Flush	RXR-AEF3415	No
Convenience Outlet, Unfused	RXR-BN01	Yes
Dual Enthalpy Kit (for Honeywell Jade™)	RXR-BV01	No
Dual Enthalpy Kit DDC (for Honeywell DDC)	RXR-BV02	No
Dual Enthalpy, Temperature and Humidity Sensor (for Siemens)	PD555460	No
Electric Heater Kits	RXJJ-DD10CP	Yes
	RXJJ-DD15CP	Yes
	RXJJ-DD20CP	Yes
	RXJJ-DD30CP	Yes
	RXJJ-DD40CP	Yes
	RXJJ-DD10DNV	Yes
	RXJJ-DD15DNV	Yes
	RXJJ-DD20DNV	Yes
	RXJJ-DD30DNV	Yes
RXJJ-DD40DNV	Yes	
Freeze Stat Kit	RXR-AM01	Yes
Fresh Air Damper, Manual	RXR-ADA1	No
Fresh Air Damper, Motorized	RXR-ADB1	No
Fresh Air Damper, Motorized (DDC)	RXR-ADC1	No
Low-Ambient Control Kit	RXR-A04	Yes
MERV 8 Filter 7.5/8.5 Ton	RXMF-M08A22020	No
MERV 8 Filter 10 Ton	RXMF-M08A22520	No
MERV 13 Filter 7.5/8.5 Ton	RXMF-M13A22020	No
MERV 13 Filter 10 Ton	RXMF-M13A22520	No
Power Exhaust (230V) Kit, Convertible MicroMetl	RXR-CDF01C	No

Accessory	Model Number	Factory Installation Available?
Power Exhaust (230V) Kit, Convertible MicroMetl	RXR-CDF01C	No
Power Exhaust (460V) Kit, Convertible MicroMetl	RXR-CDF01D	No
Power Exhaust (230V) Kit for Downflow Economizer (RRS)	RXR-RDF01C	No
Power Exhaust (460V) Kit for Downflow Economizer (RRS)	RXR-RDF01D	No
Power Exhaust (230V) Kit for Horizontal Economizer (RRS)	RXR-RDF03C	No
Power Exhaust (460V) Kit for Horizontal Economizer (RRS)	RXR-RDF03D	No
Roofcurb, 14"	RXKG-DDD14	No
Roofcurb, 14" Welded	RXKG-SD14	No
Roofcurb, 24"	RXKG-DDD24	No
Roofcurb, 24" Welded	RXKG-SD24	No
Roofcurb Adapter ²	RXR-DDCAE	No
Outdoor Coil Louver Kit - 7.5 & 8.5 Ton	RXR-ADD04A	Yes
Outdoor Coil Louver Kit - 10 ton	RXR-ADD04B	Yes
Single Point Wiring Kit	RXJX-AC0605	No
	RXJX-AC0805	No
	RXJX-AD0405	No
	RXJX-AD0605	No
	RXJX-AD0409	No
	RXJX-AC0909	No
	RXJX-AD0609	No
Sensor, Carbon Dioxide (Wall Mount)	RXR-AR02	No
Sensor, Room Humidity	RHC-ZNS4	No
Sensor, Room Temperature and Relative Humidity	RHC-ZNS5	No
Smoke Detector Kit, Return	RXR-BS03	No
Smoke Detector Kit, Return/Supply	RXR-BS04	No
Unfused Service Disconnect	RXR-BP01	Yes
UV-C Kit 208V/230V Ren D Cabinet	RXR-UVC34D	No
UV-C Transformer 460V/575V Ren D Cabinet	RXR-UVCTD	No

¹One (1) Comfort Alert required per compressor.

²Compatible with roofcurbs RXKG-CAE14 or RXKG-CAE24.

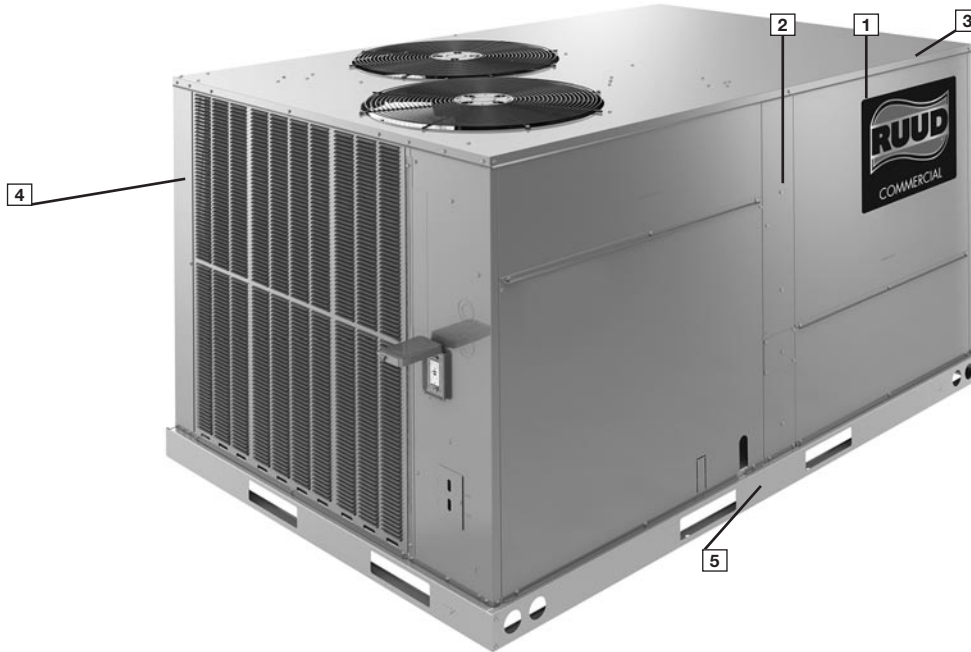

Cabinet and Foundation

Outwardly, the large Ruud Renaissance label (1) identifies the brand to the customer. The sheet-metal cabinet (2) uses 18-gauge material for structural components with an underlying coat of G90. To ensure the leak-proof integrity of these units, the design utilizes a one-piece top with a 1/8" drip lip (3) as well as gasket-protected panels and screws. The Ruud hail guard (optional) (4) sets the standard for coil protection in the industry. Electro deposition, baked-on enamel that is tested to withstand a rigorous 1000-hour salt spray test, per ASTM B117.

Anything built to last must start with the right foundation. Following that model, the foundation is comprised of 14-gauge, commercial-grade, full perimeter base rails (5) that integrate fork slots and rigging holes to save set-up time on the job site.

Easy Installation

The Renaissance line features a footprint that simplifies the replacement process by eliminating the need for a new curb adapter and being able to match inlet, outlet and electrical connections of the most common/industry-standard configurations.

Base Pan

The base pan is stamped to form a 7/8" flange around the supply and return cover, which eliminates the worry of water entering the conditioned space (6). All insulation is secured with both adhesive and mechanical fasteners, and all edges are hidden.

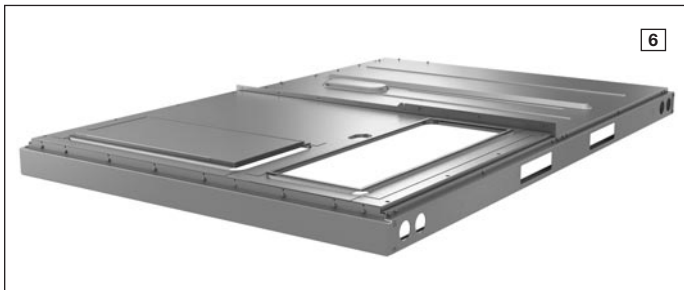

Drain Pan

The Qwik-Clean Drain Pan (7) is made from a composite material that resists the growth of harmful bacteria. With both side and center drain options, the drain pan slides out completely for easy cleaning. It also features a standard overflow switch.

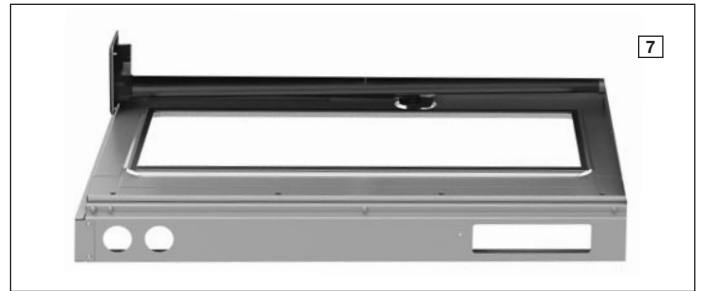

Test Standards

During development, each unit was tested to U.L. 60335-2-40, AHRI 340-360 as well as other Ruud-required reliability tests. Ruud adheres to stringent ISO 9001 quality procedures, and each unit bears the U.L. and AHRI certification labels located on the unit nameplate. Contractors can be assured that when a Ruud packaged unit arrives at the job, it is ready to go with a factory charge and quality checks.

Easy Access

All major compartments are easily accessible from the front of the unit: the electrical compartment, blower compartment, heating section, and outdoor section. Each compartment has mechanical fasteners. Panels are permanently embossed with the compartment name (e.g. control/filter access, blower access, and electric heat access). The filter compartment is accessed through a large, mechanically fastened panel. Information is readily available on the outside of the panel, with a nameplate that contains the model and serial numbers, electrical data, and other important unit information. Hinged access is available as an option for the electrical, blower, and filter compartments.

Charging Charts, Wiring Diagrams, & Labels

The unit charging chart is located on the outside of the compressor access panel. Electrical wiring diagrams are found on the control box cover, which allows contractors to move them to more readable locations. The model and serial numbers are located on the right of the control box. Having this information on the inside means easier model identification for the life of the product. The production line quality test assurance label is also placed in this location (8).

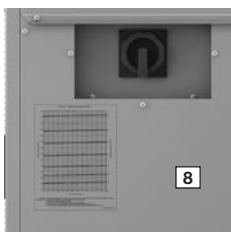

Filter Rack

Located within the filter compartment, the Qwik-Change Flex-Fit Rack (9) allows easy changeover between 2" and 4" standard size and readily available filters.



Blower Assembly

Removing three screws provides full access to the blower compartment. Inside, the Qwik-Slide Blower Assembly (10) is incredibly easy to access and remove. This makes servicing internal components such as blower motor, TXV, and microchannel coil much easier. The entire assembly slides out by removing the 3/8" screws from the blower retention bracket. The adjustable motor pulley (11) can easily be adjusted by loosening the bolts on either side of the motor mount. Removing the bolts allows for easy removal of the blower pulley by pushing the blower assembly up to loosen the belt. Once the pulley is removed, the motor sheave can be adjusted to the desired number of turns, ranging from 0 to 6 turns open.

Where the demands for the job require high static, Ruud offers drives that deliver nominal airflow up to 2" of static. By referring to the airflow performance tables listed in the installation instructions, proper static pressure and CFM requirements can be dialed in. The scroll housing (12) and blower scroll provide quiet and efficient airflow. The blower sheave is secured by an "H" bushing that firmly secures the pulley to the blower shaft, resulting in years of trouble-free operation. The "H" bushing allows for easy removal of the blower pulley from the shaft. This is an improvement from a set screw, which can score the shaft and create burrs that make blower-pulley removal difficult.

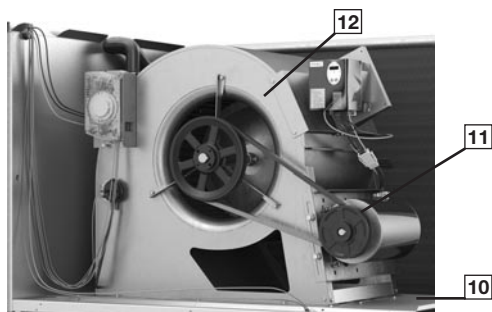

High and Low Pressure Switches & Freeze Stat

High-pressure (13) and low-pressure (14) switches are standard. They are located in the outdoor section along with the low-ambient control (15). The optional Freeze Stat (16) (standard on models with ClearControl), is clipped onto the suction line in the blower compartment. The low ambient control allows the compressor to operate down to 0 degrees ambient temperature by cycling the outdoor fans on high-pressure. The high-pressure switch shuts off the compressors if pressures exceeding 610 PSIG are detected. The low-pressure switch shuts off the compressors if low-pressure is detected due to loss of charge. Built-in Smart Logic reduces nuisance calls by only shutting off compressors after the third detection. The freeze stat protects the compressor if the evaporator coil gets too cold (below freezing) due to low airflow.

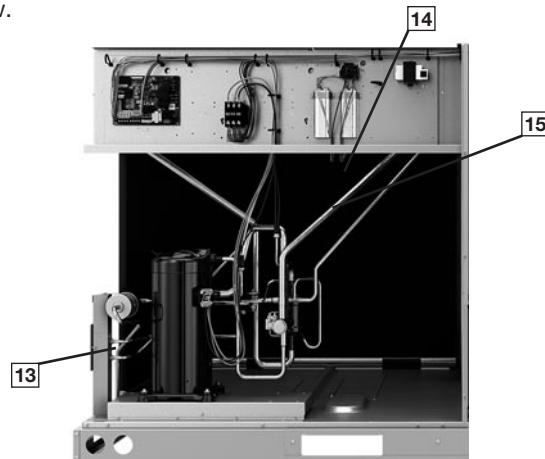

MicroChannel Evaporator & TXV

The MicroChannel Evaporator (17) is accessible through the blower compartment, and through the filter rack, to simplify cleaning. The evaporator uses MicroChannel technology for maximum heat transfer, light weight, fewer manually brazed connections and reduced refrigerant charge. The TXV metering device maintains superheat over a wide range of varying temperatures optimizing unit performance for all conditions.

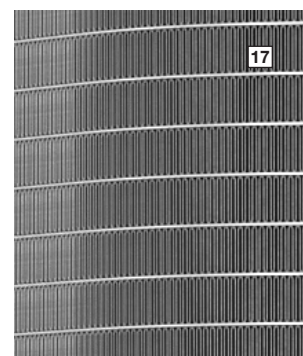

Control Box

Inside the control box (18), each electrical component is clearly labeled; that label matches the component to the wire diagram for ease of trouble shooting. All wiring is numbered on each end of the termination and is color-coded to match the wiring diagram. The control transformer has a low voltage circuit breaker that trips if an electrical short occurs. There is a blower contactor and compressor contactor for each compressor.

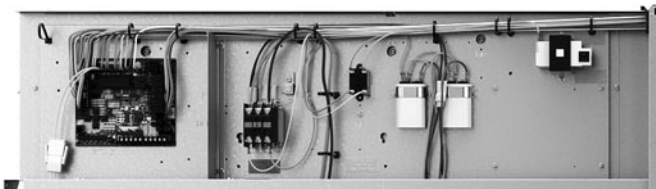

ClearControl

The optional ClearControl system consisting of a rooftop unit controller, temperature sensors, and pressure sensors, allows real-time monitoring and communication between rooftop units. The Rooftop Unit Controller (RTU-C) that is factory mounted and wired into the control panel. The RTU-C is a solid-state, micro-processor-based control board that provides flexible control and extensive diagnostics for all unit functions. The RTU-C, using proportional/integral control algorithms, performs specific unit functions that govern unit operation in response to zone conditions, system temperatures, system pressures, ambient conditions, and electrical inputs. The RTU-C features a 16 x 2 character LCD display and a five-button keypad for local configuration and direct diagnosis of the system (20). Features include a clogged filter switch (CFS), fan proving switch (FPS), return air temperature sensor (RAT), discharge air temperature sensor (DAT), and outdoor air temperature sensor (OAT). Freeze sensors (FS) are used in place of freeze stats to allow measurement of refrigerant suction line temperatures.

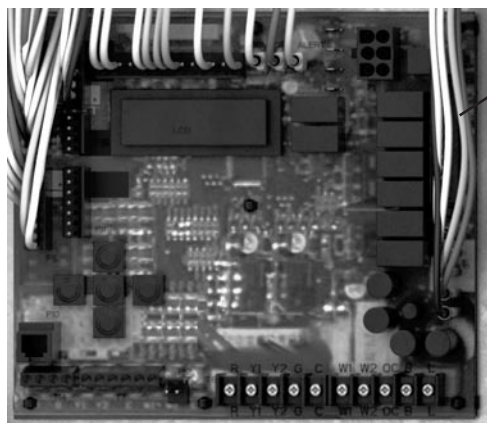

The RHPD with the RTU-C is specifically designed to be applied in four distinct applications:

- 1. BACnet® Communication** — The RHPD is compatible with a third party building management system that supports the BACnet Application Specific Controller device profile, with the use of a field-installed BACnet Communication Module. The BACnet Communication Module plugs onto the unit RTU-C controller and allows communication between the RTU-C and the BACnet MSTP network. A zone sensor, a BACnet network zone sensor, a BACnet thermostat, or DDC controller may be used to send the zone temperature or thermostat demands to the RTU-C. The BACnet Communication Module is compatible with MSTP EIA-485 daisy chain networks communicating at 38.4 bps. It is compatible with twisted pair, shielded cables.
- 2. LonWorks® Communication** — The RHPD is compatible with a third party building management system that supports the LonMark Space Comfort Controller (SCC) functional profile or LonMark Discharge Air Controller (DAC) functional profile. This is accomplished with a field-installed LonMark communication module. The LonMark Communication Module plugs onto the RTU-C controller and allows communication between the RTU-C and a LonWorks network. A zone sensor, a LonTalk network zone sensor, or a LonTalk thermostat or DDC controller may be used to send the zone temperature or thermostat demands to the RTU-C. The LonMark Communication Module utilizes an FTT-10A free topology transceiver communicating at 78.8 kbps. It is compatible with Echelon qualified, twisted pair cable, Belden 8471, or NEMA Level 4 cables. The module can communicate up to 1640 feet with no repeater. The LonWorks limit of 64 nodes per segment applies to this device.
- 3. 24V Thermostat Compatibility** — The RHPD is compatible with a programmable 24 volt thermostat. Connections are made via conventional thermostat screw terminals. Extensive unit status and diagnostics are displayed on the LCD screen of the RTU-C.
- 4. Zone Sensor Compatibility** — The RHPD is compatible with a zone sensor and a mechanical or solid state time clock connected to the RTU-C. Extensive unit status and diagnostics are displayed on the LCD screen of the RTU-C.

Comfort Alert

A factory or field-installed Comfort Alert (21) module is available for power phase-monitoring protection and additional compressor diagnostics. The alarms can be displayed on the RTU-C display, through the (BAS) network, or connected to the “L-Terminal” of a thermostat for notification.

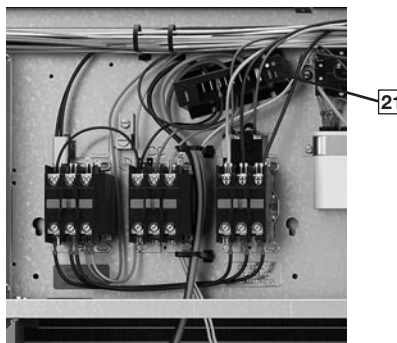

Variable Frequency Drive

The supply fan Variable Frequency Drive (VFD) (22) optimizes energy usage year round by providing a lower speed for first stage cooling operation, improving IEER over the conventional constant fan system. Operating in the constant fan mode at the reduced speed can use as little as 1/5 of the energy of a conventional constant fan system. Also, by operating at a lower speed on first stage cooling, up to 126% more moisture is removed, improving comfort during low load operation. The VFD comes standard. The VFD supply fan factory option meets California Title 24 and ASHRAE 90.1-2022 requirements for multi blower speed control. VFD also ramps up to the desired speed, reducing stress on the supply fan components and noise from a sudden inrush of air. Because the airflow is cut in half during first stage cooling and constant fan operation, noise is much less during these modes of operation.



Convenience Outlet

For added convenience in the field, factory-installed option of non-powered convenience outlet (23) is available. Low and high voltage can enter from the side or through the base. Low-voltage connections are made through the low-voltage terminal strip. For ease of access, the U.L.-required low voltage barrier can be temporarily removed for low-voltage termination and then reinstalled. The high-voltage connection is terminated at the number 1 compressor contactor.

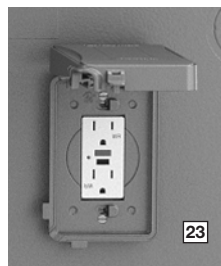

External Lockable Gauge Ports

To the right left of the compressor compartment are the externally mounted lockable gauge ports. They are permanently identified by embossed lettering that identifies the compressor circuit, high-pressure connection, (24) and low-pressure connection (25). Because the gauge ports are mounted externally, an accurate diagnostic of system operation can be performed without removing access panels. Brass caps on the Schrader fitting ensure the gauge parts are leak proof.

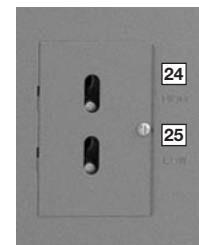

Compressor

The compressor compartment houses the heartbeat of the unit. The scroll compressor (26) is known for its long life and for reliable, quiet, and efficient operation. The suction and discharge lines are designed with shock loops (27) to absorb the strain and stress that the starting torque, steady state operation, and shut-down cycle impose on the refrigerant tubing. The units have two stages of efficient cooling operation. Each unit comes standard with a filter dryer.



Condenser Fans

The condenser fan motors (28) can easily be accessed and maintained through the top of the unit. A down-mount fan provides corrosion protection and easy removal. The polarized plug connection allows the motor to be changed quickly and eliminates the need to snake wires through the unit.



MicroChannel Condenser Technology

The outdoor coil uses the latest MicroChannel technology (29) for the most effective method of heat transfer. The outdoor coil is protected by optional louvered panels, which allow unobstructed airflow while protecting the unit from both the environment and vandalism.

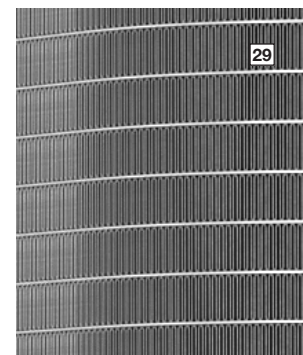

Coil Coating

Every unit offers the option of factory-applied E-Coat condenser coating (30) that delivers superior corrosion resistance for outdoor coils to operate in the harshest of environments.



Economizer and Dampers

Each unit is designed for both down flow or horizontal applications (31) for job configuration flexibility. The return air compartment can also contain an economizer. Each unit is pre-wired for the economizer to allow quick, plug-in installation. Available as a factory-installed option, the economizer provides free cooling when outdoor conditions are suitable and also provides fresh air to meet local requirements. It comes standard with single enthalpy controls, which can be upgraded to dual enthalpy easily in the field. The economizer control has a minimum position set point, an outdoor-air set point, a mixed-air set point, and a CO₂ set point. Barometric relief is standard on all economizers.

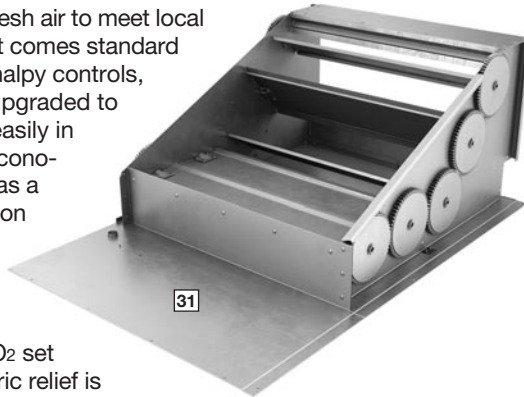

Power Exhaust is easily field-installed. The power exhaust is housed in the barometric relief opening and is easily slipped in with a plugin assembly. The wire harness to the economizer also has accommodations for a smoke detector.

The damper minimum position, actual damper position, power exhaust on/off set point, mixed air temperature limit set point, and Demand Controlled Ventilation (DCV) set point can be read and adjusted at the unit controller display or remotely through a network connection. The Space CO₂ level, mixed air temperature, and Economizer Status (free cooling available, single or dual enthalpy) can be read at the unit controller display or remotely through a network connection. Economizer faults will trigger a network alarm and can be read at the unit controller display or remotely through a network connection.

Roofcurb

The Ruud roofcurb (32) is made for tool-less assembly at the jobsite by engaging tabs in slots of adjacent curb sides, which makes the assembly process quick and easy.



Refrigerant Leak Detection

In the event of a detected refrigerant leak, the refrigerant leak detection sensor will trigger the mitigation procedure that shuts off the compressor(s) and turns on the indoor blower motor.

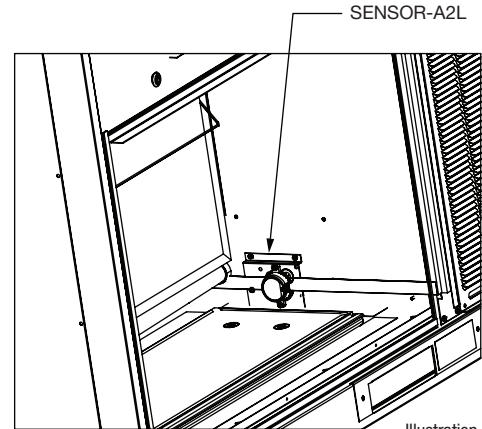
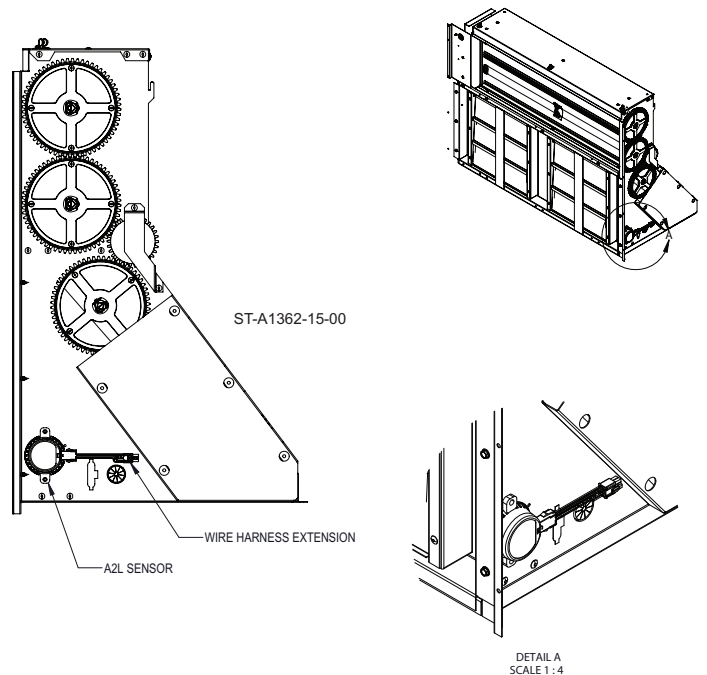

Illustration
ST-A1365-27-00

If a field-installed vertical economizer will be installed during the unit installation, the A2L leak detection sensor must be relocated as shown below. For more information, refer to the unit installation and Operation Manual.



R **HP** **D** **Y** **B** **090** **A** **C** **F** **15** **2** **A** **A** *******
1 **23** **4** **5** **6** **789** **10** **11** **12** **13 14** **15** **16** **17** **18 19 20**

1—Brand

R = Ruud

2, 3—Unit Type

HP = Packaged Heat Pump

4—Cabinet Type

D = Medium Commercial

5—Refrigerant

Y = R-454B

6—Efficiency Level

B = Standard Efficiency

7, 8, 9—Capacity

090 = 7.5 Ton

102 = 8.5 Ton

120 = 10 Ton

10—Major Series

A = 1st Design

11—Voltage

C = 3 PH, 208-230V, 60 Hz

D = 3 PH, 460V, 60 Hz

12—Drive

F = Belt Drive – VFD Low

G = Belt Drive – VFD Medium

H = Belt Drive – VFD High

13, 14—Heat Capacity

00 = No Heat

10 = 10 kW

15 = 15 kW

20 = 20 kW

30 = 30 kW

40 = 40 kW

15—Number of Stages

0 = No stages

1 = 1 stage

2 = 2 stage

16—Control

A = CoreCommand

B = CoreCommand &
Comfort Alert

C = ClearControl

D = ClearControl &
Comfort Alert

17—Minor Series

A = 1st Design

18, 19, 20—Option Code

See next page

FACTORY-INSTALLED OPTION CODES FOR RHPD (7.5 TO 10 TON)

18				19			20				
LV = Louver protection				LF = Low Ambient / Freeze Stat			EC = Economizer				
HA = Hinged Access				NP = Non-powered Convenience Outlet			SS = Supply Smoke				
CC = Coil Coating							RS = Return Smoke				
Option code character highlighted below											
A	None			A	None			0	None		
B	LV			B	LF			1	EC		
C	HA			C	NP			2	RS		
D	LV	HA		D	LF	NP		3	EC	RS	
E	LV	CC						4	SS	RS	
F	LV	HA	CC					5	EC	SS	RS

Instructions for Factory-Installed Option(s) Selection

Note: Three characters following the model number will be utilized to designate a factory-installed option or combination of options. If no factory option(s) is required, "AAO" follows the model number.

- **Step 1:** In the table above, based on the desired features, choose option code character from highlighted options on the left side under the number 18. For example, the option code character "E" has Louver protection and Coil Coating.
- **Step 2:** In the table above, based on the desired features, choose option code character from highlighted options on the left side under the number 19. For example, the option code character "D" has Low Ambient / Freeze Stat and Non-powered convenience outlet.
- **Step 3:** In the table above, based on the desired features, choose option code character from highlighted options on the left side under the number 20. For example, the option code character "3" has Economizer and Return Smoke.
- The resulting option code from examples above is: "ED3"
- **Step 4:** Add your option code selection to the end of model number

◦ Example: RHPDYB090ACF150AA ED3 = RHPDYB090ACF150AAED3

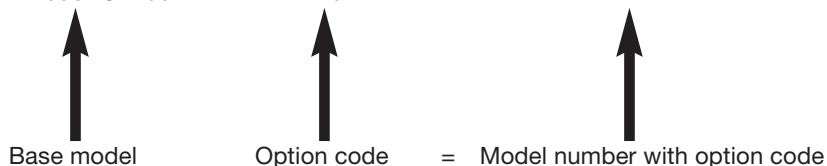

To select an RHPD Cooling and Heating unit to meet a job requirement, follow this procedure, with example, using data supplied in this specification sheet.

1. DETERMINE COOLING AND HEATING REQUIREMENTS AND SPECIFIC OPERATING CONDITIONS FROM PLANS AND SPECS.

Example:

Voltage—	230 V – 3 Phase – 60 Hz
Total Cooling Capacity—	118,000 Btu/h [34.57 kW]
Sensible Cooling Capacity—	79,600 Btu/h [23.32 kW]
Heating Capacity—	150,000 Btu/h [40 kW]
*Condenser Entering Air—	95°F [35.0°C] DB
*Evaporator Mixed Air Entering—	65°F [18.3°C] WB 78°F [25.6°C] DB
*Indoor Air Flow (vertical)—	3600 CFM [1699 L/s]
*External Static Pressure—	0.40 in. WG [.10 kPa]

2. SELECT UNIT TO MEET COOLING REQUIREMENTS.

Since total cooling is within the range of a nominal 10 ton [35.1 kW] unit, enter cooling performance table at 95°F [35.0°C] DB condenser inlet air. Interpolate between 63°F [17.2°C] WB and 67°F [19.4°C] to determine total and sensible capacity and power input for 65°F [18.3°C] WB evaporator inlet air at 3750 CFM [1770 L/s] indoor air flow (table basis):

Total Cooling Capacity = 118,900 Btu/h [34.82 kW]
Sensible Cooling Capacity = 99,950 Btu/h [29.27 kW]
Power Input (Compressor and Cond. Fans) = 8,950 watts
Use formula $[1.10 \times \text{CFM} \times (1 - \text{DR}) \times (\text{dbE} - 80)]$ in note to determine sensible capacity at 80°F [26.7°C] DB evaporator entering air:

$99,950 + (1.10 \times 3,600 \times (1 - 0.03) \times (78 - 80))$
Sensible Cooling Capacity = 92,268 Btu/h [27.02 kW]

3. CORRECT CAPACITIES OF STEP 2 FOR ACTUAL AIR FLOW.

Select factors from airflow correction table at 3600 CFM [1699 L/s] and apply to data obtained in step 2 to obtain gross capacity:

Total Capacity = $118,900 \times 0.98 = 116,522$ Btu/h [34.12 kW]
Sensible Capacity = $92,268 \times 0.95 = 87,655$ Btu/h [25.67 kW]
Power Input = $8,950 \times 0.99 = 8,861$ Watts

These are Gross Capacities, not corrected for blower motor heat or power.

4. DETERMINE BLOWER SPEED AND WATTS TO MEET SYSTEM DESIGN.

Enter Indoor Blower performance table at 3600 CFM [1699 L/s]. Total ESP (external static pressure) per the spec of 0.40 in. WG [.10 kPa] includes the system duct and grilles. Add from the table “Component Air Resistance,” 0.076 in. WG [.02 kPa] for wet coil, 0 in. WG [.00 kPa] for downflow air flow for a total selection static pressure of 0.476 (0.5) in. WG [.12 kPa], and determine:

RPM = 771
WATTS = 1,494
DRIVE = F (VFD, low static)

5. CALCULATE INDOOR BLOWER Btu/h HEAT EFFECT FROM MOTOR WATTS, STEP 4.

$$1,576 \times 3.412 = 5,377 \text{ Btu/h [1.57 kW]}$$

6. CALCULATE NET COOLING CAPACITIES, EQUAL TO GROSS CAPACITY, STEP 3, MINUS INDOOR BLOWER MOTOR HEAT.

$$\text{Net Total Capacity} = 116,522 - 5,377 = 111,145 \text{ Btu/h [32.54 kW]}$$

$$\text{Net Sensible Capacity} = 87,655 - 5,377 = 82,278 \text{ Btu/h [24.09 kW]}$$

7. CALCULATE UNIT INPUT AND JOB EER.

$$\text{Total Power Input} = 8,861 \text{ (step 3)} + 1,576 \text{ (step 4)} = 10,437 \text{ Watts}$$

$$\text{EER} = \frac{\text{Net Total Btu/h [kW] (step 6)}}{\text{Power Input, Watts (above)}} = \frac{111,145}{10,437} = 10.65$$

8. SELECT UNIT HEATING CAPACITY.

From Heater Kit Table select kW to meet heating capacity requirement; multiply kW x 3412 to convert to Btu/h.

Use 40 kW Heater Kit

Heater Kit Model:	Heater Kit Capacity:
RXJJ-DD40CP	135,120 Btu/h [39.6 kW]

Add indoor blower heat effect (step 5) to Heater Kit Capacity to get total heating capacity:

$$135,120 + 5,377 = 140,497 \text{ Btu/h [41.1 kW]}$$

9. CHOOSE MODEL RHPDYB120ACF402AA.

*NOTE: These operating conditions are typical of a commercial application in a 95°F/79°F [35°C/26°C] design area with indoor design of 76°F [24°C] DB and 50% RH and 10% ventilation air, with the unit roof mounted and centered on the zone it conditions by ducts.

[] Designates Metric Conversions

GENERAL DATA—RHPDYB MODELS—7.5–10 TON [26.4–35.1 kW]

Model RHPDYB Series	090ACF	090ACG	090ACH	090ADF
Cooling Performance^A				CONTINUED →
Nominal Cooling Capacity Btu/h [kW]	90,000 [26.37]	90,000 [26.37]	90,000 [26.37]	90,000 [26.37]
EER / IEER ^B	11/14.1	11/14.1	11/14.1	11/14.1
Nominal CFM/AHRI Rated CFM [L/s]	3,000/3,300 [1,416/1,557]	3,000/3,300 [1,416/1,557]	3,000/3,300 [1,416/1,557]	3,000/3,300 [1,416/1,557]
AHRI Net Cooling Capacity Btu/h [kW]	86,000 [25.2]	86,000 [25.2]	86,000 [25.2]	86,000 [25.2]
Net Sensible Capacity Btu/h [kW]	64,500 [18.9]	64,500 [18.9]	64,500 [18.9]	64,500 [18.9]
Net Latent Capacity Btu/h [kW]	21,500 [6.3]	21,500 [6.3]	21,500 [6.3]	21,500 [6.3]
Net System Power [kW]	7.82	7.82	7.82	7.82
Heating Performance (Heat Pumps)				
High Temp. Btu/h [kW] Rating @ 47°F	84,000 [24.62]	84,000 [24.62]	84,000 [24.62]	84,000 [24.62]
System Power kW/COP @ 47°F	7.24/3.4	7.24/3.4	7.24/3.4	7.24/3.4
Low Temp. Btu/h [kW] Rating @ 17°F	48,000 [14.06]	48,000 [14.06]	48,000 [14.06]	48,000 [14.06]
System Power kW/COP @ 17°F	6.25/2.25	6.25/2.25	6.25/2.25	6.25/2.25
Compressor				
No./Stage/Type	1/2/Scroll	1/2/Scroll	1/2/Scroll	1/2/Scroll
Outdoor Sound Rating (dB)^C	87	87	87	87
Outdoor Coil - Fin Type	Louvered	Louvered	Louvered	Louvered
Tube Type	MicroChannel	MicroChannel	MicroChannel	MicroChannel
Rifled: Tube Size OD or MicroChannel: Depth in. [mm]	1 [25.4]	1 [25.4]	1 [25.4]	1 [25.4]
Face Area sq. ft. [sq. m]	22.8 [2.12]	22.8 [2.12]	22.8 [2.12]	22.8 [2.12]
Rows / FPI [FPcm]	1 / 16 [6]	1 / 16 [6]	1 / 16 [6]	1 / 16 [6]
Indoor Coil - Fin Type	Louvered	Louvered	Louvered	Louvered
Tube Type	MicroChannel	MicroChannel	MicroChannel	MicroChannel
Rifled: Tube Size OD or MicroChannel: Depth in. [mm]	1.26 [32]	1.26 [32]	1.26 [32.00]	1.26 [32.00]
Face Area sq. ft. [sq. m]	10.9 [1.01]	10.9 [1.01]	10.9 [1.01]	10.9 [1.01]
Rows / FPI [FPcm]	1 / 20 [8]	1 / 20 [8]	1 / 20 [8]	1 / 20 [8]
Refrigerant Control	TXV	TXV	TXV	TXV
Drain Connection No./Size in. [mm]	1 / 0.75 [19.05]	1 / 0.75 [19.05]	1 / 0.75 [19.05]	1 / 0.75 [19.05]
Outdoor Fan - Type	Propeller	Propeller	Propeller	Propeller
No. Used/Diameter in. [mm]	2/24.0 [609.6]	2/24.0 [609.6]	2/24.0 [609.6]	2/24.0 [609.6]
Drive Type/No. Speeds	Direct/1	Direct/1	Direct/1	Direct/1
CFM [L/s]	8,000 [3,775]	8,000 [3,775]	8,000 [3,775]	8,000 [3,775]
No. Motors/HP	2 at 1/2 HP	2 at 1/2 HP	2 at 1/2 HP	2 at 1/2 HP
Motor RPM	1075	1075	1075	1050
Indoor Fan - Type	FC Centrifugal	FC Centrifugal	FC Centrifugal	FC Centrifugal
No. Used/Diameter in. [mm]	1/15x15 [381x381]	1/15x15 [381x381]	1/15x15 [381x381]	1/15x15 [381x381]
Drive Type	Belt (Adjustable)	Belt (Adjustable)	Belt (Adjustable)	Belt (Adjustable)
No. Speeds	Single Speed	Single Speed	Single Speed	Single Speed
No. Motors	1	1	1	1
Motor HP	2	3	3	2
Motor RPM	1725	1725	1725	1725
Motor Frame Size	56	56	56	56
Filter - Type	Disposable	Disposable	Disposable	Disposable
Furnished	Yes	Yes	Yes	Yes
(NO.) Size Recommended in. [mm x mm x mm]	(4)2x20x20 [51x508x508]	(4)2x20x20 [51x508x508]	(4)2x20x20 [51x508x508]	(4)2x20x20 [51x508x508]
Refrigerant Charge Oz. [g]	172.8 [4,898.8]	172.8 [4,898.8]	172.8 [4,898.8]	172.8 [4,898.8]
Weights				
Net Weight lbs. [kg]	780 [354]	790 [358]	791 [359]	780 [354]
Ship Weight lbs. [kg]	819 [371]	829 [376]	830 [377]	819 [371]

See Page 19 for Notes.

[] Designates Metric Conversions

GENERAL DATA—RHPDYB MODELS—7.5–10 TON [26.4–35.1 kW]

Model RHPDYB Series	090ADG	090ADH	102ACF	102ACG
Cooling Performance^A				CONTINUED →
Nominal Cooling Capacity Btu/h [kW]	90,000 [26.37]	90,000 [26.37]	102,000 [29.89]	102,000 [29.89]
EER / IEER ^B	11/14.1	11/14.1	11/14.1	11/14.1
Nominal CFM/AHRI Rated CFM [L/s]	3,000/3,300 [1,416/1,577]	3,000/3,300 [1,416/1,577]	3,400/3,350 [1,604/1,581]	3,400/3,350 [1,604/1,581]
AHRI Net Cooling Capacity Btu/h [kW]	86,000 [25.2]	86,000 [25.2]	96,000 [28.1]	96,000 [28.1]
Net Sensible Capacity Btu/h [kW]	64,500 [18.9]	64,500 [18.9]	72,750 [21.3]	72,750 [21.3]
Net Latent Capacity Btu/h [kW]	21,500 [6.3]	21,500 [6.3]	24,250 [7.1]	24,250 [7.1]
Net System Power [kW]	7.82	7.82	8.82	8.82
Heating Performance (Heat Pumps)				
High Temp. Btu/h [kW] Rating @ 47°F	84,000 [24.62]	84,000 [24.62]	96,000 [28.1]	96,000 [28.1]
System Power kW/COP @ 47°F	7.24/3.4	7.24/3.4	8.36/3.4	8.36/3.4
Low Temp. Btu/h [kW] Rating @ 17°F	48,000 [14.06]	48,000 [14.06]	56,000 [16.4]	56,000 [16.4]
System Power kW/COP @ 17°F	6.25/2.25	6.25/2.25	7.29/2.25	7.29/2.25
Compressor				
No./Stage/Type	1/2/Scroll	1/2/Scroll	1/2/Scroll	1/2/Scroll
Outdoor Sound Rating (dB)^C				
Outdoor Coil - Fin Type	Louvered	Louvered	Louvered	Louvered
Tube Type	MicroChannel	MicroChannel	MicroChannel	MicroChannel
Rifled: Tube Size OD or MicroChannel: Depth in. [mm]	1 [25.4]	1 [25.4]	1.26 [32.00]	1.26 [32.00]
Face Area sq. ft. [sq. m]	22.8 [2.12]	22.8 [2.12]	28.8 [2.68]	28.8 [2.68]
Rows / FPI [FPcm]	1 / 16 [6]	1 / 16 [6]	1 / 16 [6]	1 / 16 [6]
Indoor Coil - Fin Type	Louvered	Louvered	Louvered	Louvered
Tube Type	MicroChannel	MicroChannel	MicroChannel	MicroChannel
Rifled: Tube Size OD or MicroChannel: Depth in. [mm]	1.26 [32.00]	1.26 [32.00]	1.26 [32.00]	1.26 [32.00]
Face Area sq. ft. [sq. m]	10.9 [1.01]	10.9 [1.01]	13.2 [1.23]	13.2 [1.23]
Rows / FPI [FPcm]	1 / 20 [8]	1 / 20 [8]	1 / 20 [8]	1 / 20 [8]
Refrigerant Control	TXV	TXV	TXV	TXV
Drain Connection No./Size in. [mm]	1 / 0.75 [19.05]	1 / 0.75 [19.05]	1 / 0.75 [19.05]	1 / 0.75 [19.05]
Outdoor Fan - Type	Propeller	Propeller	Propeller	Propeller
No. Used/Diameter in. [mm]	2/24.0 [609.6]	2/24.0 [609.6]	2/24.0 [609.6]	2/24.0 [609.6]
Drive Type/No. Speeds	Direct/1	Direct/1	Direct/1	Direct/1
CFM [L/s]	8,000 [3775]	8,000 [3775]	8,000 [3775]	8,000 [3775]
No. Motors/HP	2 at 1/2 HP	2 at 1/2 HP	2 at 1/2 HP	2 at 1/2 HP
Motor RPM	1050	1050	1075	1075
Indoor Fan - Type	FC Centrifugal	FC Centrifugal	FC Centrifugal	FC Centrifugal
No. Used/Diameter in. [mm]	1/15x15 [381x381]	1/15x15 [381x381]	1/15x15 [381x381]	1/15x15 [381x381]
Drive Type	Belt (Adjustable)	Belt (Adjustable)	Belt (Adjustable)	Belt (Adjustable)
No. Speeds	Single Speed	Single Speed	Single Speed	Single Speed
No. Motors	1	1	1	1
Motor HP	3	3	2	3
Motor RPM	1725	1725	1725	1725
Motor Frame Size	56	56	56	56
Filter - Type	Disposable	Disposable	Disposable	Disposable
Furnished	Yes	Yes	Yes	Yes
(NO.) Size Recommended in. [mm x mm x mm]	(4)2x20x20 [51x508x508]	(4)2x20x20 [51x508x508]	(4)2x25x20 [51x635x508]	(4)2x25x20 [51x635x508]
Refrigerant Charge Oz. [g]	172.8 [4,898.8]	172.8 [4,898.8]	211.2 [5,987.4]	211.2 [5,987.4]
Weights				
Net Weight lbs. [kg]	790 [358]	791 [359]	814 [369]	824 [373]
Ship Weight lbs. [kg]	829 [376]	830 [377]	853 [387]	863 [391]

See Page 19 for Notes.

[] Designates Metric Conversions

GENERAL DATA—RHPDYB MODELS—7.5–10 TON [26.4–35.1 kW]

Model RHPDYB Series	102ACH	102ADF	102ADG	102ADH
Cooling Performance^A				CONTINUED →
Nominal Cooling Capacity Btu/h [kW]	102,000 [29.89]	102,000 [29.89]	102,000 [29.89]	102,000 [29.89]
EER / IEER ^B	11/14.1	11/14.1	11/14.1	11/14.1
Nominal CFM/AHRI Rated CFM [L/s]	3,400/3,350 [1,604/1,581]	3,400/3,350 [1,604/1,581]	3,400/3,350 [1,604/1,581]	3,400/3,350 [1,604/1,581]
AHRI Net Cooling Capacity Btu/h [kW]	96,000 [28.1]	96,000 [28.1]	96,000 [28.1]	96,000 [28.1]
Net Sensible Capacity Btu/h [kW]	72,750 [21.3]	72,750 [21.3]	72,750 [21.3]	72,750 [21.3]
Net Latent Capacity Btu/h [kW]	24,250 [7.1]	24,250 [7.1]	24,250 [7.1]	24,250 [7.1]
Net System Power [kW]	8.82	8.82	8.82	8.82
Heating Performance (Heat Pumps)				
High Temp. Btu/h [kW] Rating @ 47°F	96,000 [28.1]	96,000 [28.1]	96,000 [28.1]	96,000 [28.1]
System Power kW/COP @ 47°F	8.36/3.4	8.36/3.4	8.36/3.4	8.36/3.4
Low Temp. Btu/h [kW] Rating @ 17°F	56,000 [16.4]	56,000 [16.4]	56,000 [16.4]	56,000 [16.4]
System Power kW/COP @ 17°F	7.29/2.25	7.29/2.25	7.29/2.25	7.29/2.25
Compressor				
No./Stage/Type	1/2/Scroll	1/2/Scroll	1/2/Scroll	1/2/Scroll
Outdoor Sound Rating (dB)^C	82	82	82	82
Outdoor Coil - Fin Type	Louvered	Louvered	Louvered	Louvered
Tube Type	MicroChannel	MicroChannel	MicroChannel	MicroChannel
Rifled: Tube Size OD or MicroChannel: Depth in. [mm]	1.26 [32.00]	1.26 [32.00]	1.26 [32.00]	1.26 [32.00]
Face Area sq. ft. [sq. m]	28.8 [2.68]	28.8 [2.68]	28.8 [2.68]	28.8 [2.68]
Rows / FPI [FPcm]	1 / 16 [6]	1 / 16 [6]	1 / 16 [6]	1 / 16 [6]
Indoor Coil - Fin Type	Louvered	Louvered	Louvered	Louvered
Tube Type	MicroChannel	MicroChannel	MicroChannel	MicroChannel
Rifled: Tube Size OD or MicroChannel: Depth in. [mm]	1.26 [32.00]	1.26 [32.00]	1.26 [32.00]	1.26 [32.00]
Face Area sq. ft. [sq. m]	13.2 [1.23]	13.2 [1.23]	13.2 [1.23]	13.2 [1.23]
Rows / FPI [FPcm]	1 / 20 [8]	1 / 20 [8]	1 / 20 [8]	1 / 20 [8]
Refrigerant Control	TXV	TXV	TXV	TXV
Drain Connection No./Size in. [mm]	1 / 0.75 [19.05]	1 / 0.75 [19.05]	1 / 0.75 [19.05]	1 / 0.75 [19.05]
Outdoor Fan - Type	Propeller	Propeller	Propeller	Propeller
No. Used/Diameter in. [mm]	2/24.0 [609.6]	2/24.0 [609.6]	2/24.0 [609.6]	2/24.0 [609.6]
Drive Type/No. Speeds	Direct/1	Direct/1	Direct/1	Direct/1
CFM [L/s]	8,000 [3775]	8,000 [3775]	8000 [3775]	8000 [3775]
No. Motors/HP	2 at 1/2 HP	2 at 1/2 HP	2 at 1/2 HP	2 at 1/2 HP
Motor RPM	1075	1050	1050	1050
Indoor Fan - Type	FC Centrifugal	FC Centrifugal	FC Centrifugal	FC Centrifugal
No. Used/Diameter in. [mm]	1/15x15 [381x381]	1/15x15 [381x381]	1/15x15 [381x381]	1/15x15 [381x381]
Drive Type	Belt (Adjustable)	Belt (Adjustable)	Belt (Adjustable)	Belt (Adjustable)
No. Speeds	Single Speed	Single Speed	Single Speed	Single Speed
No. Motors	1	1	1	1
Motor HP	3	2	3	3
Motor RPM	1725	1725	1725	1725
Motor Frame Size	56	56	56	56
Filter - Type	Disposable	Disposable	Disposable	Disposable
Furnished	Yes	Yes	Yes	Yes
(NO.) Size Recommended in. [mm x mm x mm]	(4)2x25x20 [51x635x508]	(4)2x25x20 [51x635x508]	(4)2x25x20 [51x635x508]	(4)2x25x20 [51x635x508]
Refrigerant Charge Oz. [g]	211.2 [5987.4]	211.2 [5987.4]	211.2 [5987.4]	211.2 [5987.4]
Weights				
Net Weight lbs. [kg]	825 [374]	814 [369]	824 [373]	825 [374]
Ship Weight lbs. [kg]	864 [392]	853 [387]	863 [391]	864 [392]

See Page 19 for Notes.

[] Designates Metric Conversions

GENERAL DATA—RHPDYB MODELS—7.5–10 TON [26.4–35.1 kW]

Model RHPDYB Series	120ACF	120ACG	120ACH	120ADF
Cooling Performance^A				CONTINUED →
Nominal Cooling Capacity Btu/h [kW]	120,000 [35.16]	120,000 [35.16]	120,000 [35.16]	120,000 [35.16]
EER / IEER ^B	11/14.1	11/14.1	11/14.1	11/14.1
Nominal CFM/AHRI Rated CFM [L/s]	4,000/4,000 [1,888/1,888]	4,000/4,000 [1,888/1,888]	4,000/4,000 [1,888/1,888]	4,000/4,000 [1,888/1,888]
AHRI Net Cooling Capacity Btu/h [kW]	114,000 [33.4]	114,000 [33.4]	114,000 [33.4]	114,000 [33.4]
Net Sensible Capacity Btu/h [kW]	85,500 [25.1]	85,500 [25.1]	85,500 [25.1]	85,500 [25.1]
Net Latent Capacity Btu/h [kW]	28,500 [8.4]	28,500 [8.4]	28,500 [8.4]	28,500 [8.4]
Net System Power [kW]	10.36	10.36	10.36	10.36
Heating Performance (Heat Pumps)				
High Temp. Btu/h [kW] Rating @ 47°F	112,000 [32.8]	112,000 [32.8]	112,000 [32.8]	112,000 [32.8]
System Power kW/COP @ 47°F	9.65/3.4	9.65/3.4	9.65/3.4	9.65/3.4
Low Temp. Btu/h [kW] Rating @ 17°F	68,000 [19.9]	68,000 [19.9]	68,000 [19.9]	68,000 [19.9]
System Power kW/COP @ 17°F	8.86/2.25	8.86/2.25	8.86/2.25	8.86/2.25
Compressor				
No./Stage/Type	1/2/Scroll	1/2/Scroll	1/2/Scroll	1/2/Scroll
Outdoor Sound Rating (dB)^C	81	81	81	81
Outdoor Coil - Fin Type	Louvered	Louvered	Louvered	Louvered
Tube Type	MicroChannel	MicroChannel	MicroChannel	MicroChannel
Rifled: Tube Size OD or MicroChannel: Depth in. [mm]	1.26 [32]	1.26 [32]	1.26 [32.00]	1.26 [32.00]
Face Area sq. ft. [sq. m]	28.8 [2.68]	28.8 [2.68]	28.8 [2.68]	28.8 [2.68]
Rows / FPI [FPcm]	1 / 16 [6]	1 / 16 [6]	1 / 16 [6]	1 / 16 [6]
Indoor Coil - Fin Type	Louvered	Louvered	Louvered	Louvered
Tube Type	MicroChannel	MicroChannel	MicroChannel	MicroChannel
Rifled: Tube Size OD or MicroChannel: Depth in. [mm]	1.26 [32.00]	1.26 [32.00]	1.26 [32.00]	1.26 [32.00]
Face Area sq. ft. [sq. m]	13.2 [1.23]	13.2 [1.23]	13.2 [1.23]	13.2 [1.23]
Rows / FPI [FPcm]	1 / 20 [8]	1 / 20 [8]	1 / 20 [8]	1 / 20 [8]
Refrigerant Control	TXV	TXV	TXV	TXV
Drain Connection No./Size in. [mm]	1 / 0.75 [19.05]	1 / 0.75 [19.05]	1 / 0.75 [19.05]	1 / 0.75 [19.05]
Outdoor Fan - Type	Propeller	Propeller	Propeller	Propeller
No. Used/Diameter in. [mm]	2/24.0 [609.6]	2/24.0 [609.6]	2/24.0 [609.6]	2/24.0 [609.6]
Drive Type/No. Speeds	Direct/1	Direct/1	Direct/1	Direct/1
CFM [L/s]	8000 [3775]	8000 [3775]	8000 [3775]	8000 [3775]
No. Motors/HP	2 at 1/2 HP	2 at 1/2 HP	2 at 1/2 HP	2 at 1/2 HP
Motor RPM	1075	1075	1075	1050
Indoor Fan - Type	FC Centrifugal	FC Centrifugal	FC Centrifugal	FC Centrifugal
No. Used/Diameter in. [mm]	1/15x15 [381x381]	1/15x15 [381x381]	1/15x15 [381x381]	1/15x15 [381x381]
Drive Type	Belt (Adjustable)	Belt (Adjustable)	Belt (Adjustable)	Belt (Adjustable)
No. Speeds	Single Speed	Single Speed	Single Speed	Single Speed
No. Motors	1	1	1	1
Motor HP	2	3	3	2
Motor RPM	1725	1725	1725	1725
Motor Frame Size	56	56	56	56
Filter - Type	Disposable	Disposable	Disposable	Disposable
Furnished	Yes	Yes	Yes	Yes
(NO.) Size Recommended in. [mm x mm x mm]	(4)2x25x20 [51x635x508]	(4)2x25x20 [51x635x508]	(4)2x25x20 [51x635x508]	(4)2x25x20 [51x635x508]
Refrigerant Charge Oz. [g]	209.6 [5942.1]	209.6 [5942.1]	209.6 [5942.1]	209.6 [5942.1]
Weights				
Net Weight lbs. [kg]	856 [388]	866 [392]	867 [393]	856 [388]
Ship Weight lbs. [kg]	895 [406]	905 [410]	906 [411]	895 [406]

See Page 19 for Notes.

[] Designates Metric Conversions

GENERAL DATA—RHPDYB MODELS—7.5–10 TON [26.4–35.1 kW]

Model RHPDYB Series	120ADG	120ADH
Cooling Performance^A		
Nominal Cooling Capacity Btu/h [kW]	120,000 [35.16]	120,000 [35.16]
EER / IEER ^B	11/14.1	11/14.1
Nominal CFM/AHRI Rated CFM [L/s]	4,000/3,900 [1,888/1841]	4,000/3,900 [1,888/1841]
AHRI Net Cooling Capacity Btu/h [kW]	114,000 [33.4]	114,000 [33.4]
Net Sensible Capacity Btu/h [kW]	85,500 [25.1]	85,500 [25.1]
Net Latent Capacity Btu/h [kW]	28,500 [8.4]	28,500 [8.4]
Net System Power [kW]	10.36	10.36
Heating Performance (Heat Pumps)		
High Temp. Btu/h [kW] Rating @ 47°F	112,000 [32.8]	112,000 [32.8]
System Power kW/COP @ 47°F	9.65/3.4	9.65/3.4
Low Temp. Btu/h [kW] Rating @ 17°F	68,000 [19.9]	68,000 [19.9]
System Power kW/COP @ 17°F	8.86/2.25	8.86/2.25
Compressor		
No./Stage/Type	1/2/Scroll	1/2/Scroll
Outdoor Sound Rating (dB)^C		
	81	81
Outdoor Coil - Fin Type		
Tube Type	Louvered	Louvered
Tube Type	MicroChannel	MicroChannel
Rifled: Tube Size OD or MicroChannel: Depth in. [mm]	1.26 [32]	1.26 [32]
Face Area sq. ft. [sq. m]	28.8 [2.68]	28.8 [2.68]
Rows / FPI [FPcm]	1 / 16 [6]	1 / 16 [6]
Indoor Coil - Fin Type		
Tube Type	Louvered	Louvered
Tube Type	MicroChannel	MicroChannel
Rifled: Tube Size OD or MicroChannel: Depth in. [mm]	1.26 [32.00]	1.26 [32.00]
Face Area sq. ft. [sq. m]	13.2 [1.23]	13.2 [1.23]
Rows / FPI [FPcm]	1 / 20 [8]	1 / 20 [8]
Refrigerant Control	TXV	TXV
Drain Connection No./Size in. [mm]	1 / 0.75 [19.05]	1 / 0.75 [19.05]
Outdoor Fan - Type		
	Propeller	Propeller
No. Used/Diameter in. [mm]	2/24.0 [609.6]	2/24.0 [609.6]
Drive Type/No. Speeds	Direct/1	Direct/1
CFM [L/s]	8000 [3775]	8000 [3775]
No. Motors/HP	2 at 1/2 HP	2 at 1/2 HP
Motor RPM	1050	1050
Indoor Fan - Type		
	FC Centrifugal	FC Centrifugal
No. Used/Diameter in. [mm]	1/15x15 [381x381]	1/15x15 [381x381]
Drive Type	Belt (Adjustable)	Belt (Adjustable)
No. Speeds	Single Speed	Single Speed
No. Motors	1	1
Motor HP	3	3
Motor RPM	1725	1725
Motor Frame Size	56	56
Filter - Type		
	Disposable	Disposable
Furnished	Yes	Yes
(NO.) Size Recommended in. [mm x mm x mm]	(4)2x25x20 [51x635x508]	(4)2x25x20 [51x635x508]
Refrigerant Charge Oz. [g]		
	209.6 [5942.1]	209.6 [5942.1]
Weights		
Net Weight lbs. [kg]	866 [392]	867 [393]
Ship Weight lbs. [kg]	905 [410]	906 [411]

See Page 19 for Notes.

[] Designates Metric Conversions

NOTES:

- A. Cooling Performance is rated at 95°F ambient, 80°F entering dry bulb, 67°F entering wet bulb. Gross capacity does not include the effect of fan motor heat. AHRI capacity is net and includes the effect of fan motor heat. Units are suitable for operation to ±20% of nominal cfm. Units are certified in accordance with the Unitary Air Conditioner Equipment certification program, which is based on AHRI Standard 340/360.
- B. EER and Integrated Energy Efficiency (IEER) are rated in accordance with AHRI Standard 340/360 and DOE test standards.
- C. Outdoor Sound Rating shown is tested in accordance with AHRI Standard 270.

[] Designates Metric Conversions

WEIGHTED SOUND POWER LEVEL (dBA)

MODEL	STD. RATING (dBA)	FREQUENCY (Hz)						
		125	250	500	1000	2000	4000	8000
RHPDYB090	87.0	62	74	77	77	74	70	67
RHPDYB102	81.7	56	65	72	71	69	64	53
RHPDYB120	81.0	61	64	69	67	67	66	62

COOLING PERFORMANCE DATA—RHPDYB090

ENTERING INDOOR AIR @ 80°F [26.7°C] dbE ①											
wbE			71°F [21.7°C]			67°F [19.4°C]			63°F [17.2°C]		
CFM [L/s]			3600 [1699]	3025 [1428]	2400 [1133]	3600 [1699]	3025 [1428]	2400 [1133]	3600 [1699]	3025 [1428]	2400 [1133]
DR ①			.05	.09	.12	.05	.09	.12	.05	.09	.12
O U T D O O R D R Y B U L B T E M P E R A T U R E ° F [° C]	75 [23.9]	Total kBtu/h [kW]	105.5 [30.9]	102.0 [29.9]	98.1 [28.8]	101.7 [29.8]	98.3 [28.8]	94.6 [27.7]	96.8 [28.4]	93.6 [27.4]	90.1 [26.4]
		Sens kBtu/h [kW]	63.8 [18.7]	58.6 [17.2]	53.0 [15.5]	78.2 [22.9]	71.9 [21.1]	64.9 [19.0]	85.7 [25.1]	78.7 [23.1]	71.1 [20.8]
		Power	6.9	6.8	6.7	6.8	6.7	6.5	6.7	6.5	6.4
	80 [26.7]	Total kBtu/h [kW]	103.8 [30.4]	100.3 [29.4]	96.6 [28.3]	100.0 [29.3]	96.6 [28.3]	93.0 [27.3]	95.1 [27.9]	91.9 [26.9]	88.5 [25.9]
		Sens kBtu/h [kW]	63.8 [18.7]	58.6 [17.2]	52.9 [15.5]	78.2 [22.9]	71.8 [21.0]	64.9 [19.0]	85.6 [25.1]	78.7 [23.1]	71.1 [20.8]
		Power	7.3	7.1	7.0	7.1	7.0	6.8	7.0	6.8	6.7
	85 [29.4]	Total kBtu/h [kW]	101.8 [29.8]	98.4 [28.8]	94.7 [27.8]	98.0 [28.7]	94.7 [27.8]	91.2 [26.7]	93.1 [27.3]	90.0 [26.4]	86.6 [25.4]
		Sens kBtu/h [kW]	63.4 [18.6]	58.2 [17.1]	52.6 [15.4]	77.8 [22.8]	71.5 [21.0]	64.6 [18.9]	85.2 [25.0]	78.3 [22.9]	70.7 [20.7]
		Power	7.6	7.4	7.3	7.4	7.3	7.1	7.3	7.2	7.0
	90 [32.2]	Total kBtu/h [kW]	99.6 [29.2]	96.3 [28.2]	92.6 [27.1]	95.7 [28.0]	92.6 [27.1]	89.1 [26.1]	90.9 [26.6]	87.9 [25.8]	84.6 [24.8]
Sens kBtu/h [kW]		62.6 [18.3]	57.5 [16.9]	52.0 [15.2]	77.0 [22.6]	70.8 [20.8]	63.9 [18.7]	84.5 [24.8]	77.6 [22.7]	70.1 [20.5]	
Power		7.9	7.8	7.6	7.7	7.6	7.5	7.6	7.5	7.3	
95 [35]	Total kBtu/h [kW]	97.1 [28.5]	93.8 [27.5]	90.3 [26.5]	93.2 [27.3]	90.1 [26.4]	86.7 [25.4]	88.4 [25.9]	85.4 [25.0]	82.2 [24.1]	
	Sens kBtu/h [kW]	61.6 [18.1]	56.5 [16.6]	51.1 [15.0]	76.0 [22.3]	69.8 [20.5]	63.0 [18.5]	83.4 [24.4]	76.6 [22.5]	69.2 [20.3]	
	Power	8.2	8.1	7.9	8.0	7.9	7.8	7.9	7.8	7.6	
100 [37.8]	Total kBtu/h [kW]	94.3 [27.6]	91.1 [26.7]	87.7 [25.7]	90.5 [26.5]	87.4 [25.6]	84.2 [24.7]	85.6 [25.1]	82.7 [24.2]	79.6 [23.3]	
	Sens kBtu/h [kW]	60.1 [17.6]	55.2 [16.2]	49.9 [14.6]	74.5 [21.8]	68.5 [20.1]	61.9 [18.1]	82.0 [24.0]	75.3 [22.1]	68.1 [20.0]	
	Power	8.5	8.4	8.2	8.3	8.2	8.1	8.2	8.1	7.9	
105 [40.6]	Total kBtu/h [kW]	91.2 [26.7]	88.2 [25.8]	84.9 [24.9]	87.4 [25.6]	84.5 [24.8]	81.3 [23.8]	82.6 [24.2]	79.8 [23.4]	76.8 [22.5]	
	Sens kBtu/h [kW]	58.4 [17.1]	53.6 [15.7]	48.4 [14.2]	72.8 [21.3]	66.8 [19.6]	60.4 [17.7]	80.2 [23.5]	73.7 [21.6]	66.6 [19.5]	
	Power	8.8	8.7	8.5	8.7	8.5	8.4	8.5	8.4	8.2	
110 [43.3]	Total kBtu/h [kW]	87.9 [25.8]	85.0 [24.9]	81.8 [24.0]	84.1 [24.6]	81.3 [23.8]	78.2 [22.9]	79.2 [23.2]	76.6 [22.5]	73.7 [21.6]	
	Sens kBtu/h [kW]	56.3 [16.5]	51.7 [15.2]	46.7 [13.7]	70.7 [20.7]	64.9 [19.0]	58.6 [17.2]	78.1 [22.9]	71.8 [21.0]	64.8 [19.0]	
	Power	9.1	9.0	8.8	9.0	8.8	8.7	8.8	8.7	8.5	
115 [46.1]	Total kBtu/h [kW]	84.4 [24.7]	81.5 [23.9]	78.5 [23.0]	80.5 [23.6]	77.8 [22.8]	74.9 [22.0]	75.7 [22.2]	73.1 [21.4]	70.4 [20.6]	
	Sens kBtu/h [kW]	53.8 [15.8]	49.4 [14.5]	44.7 [13.1]	68.2 [20.0]	62.7 [18.4]	56.6 [16.6]	75.7 [22.2]	69.5 [20.4]	62.8 [18.4]	
	Power	9.4	9.3	9.1	9.3	9.1	9.0	9.2	9.0	8.8	
120 [48.9]	Total kBtu/h [kW]	80.5 [23.6]	77.8 [22.8]	74.9 [22.0]	76.7 [22.5]	74.1 [21.7]	71.3 [20.9]	71.8 [21.0]	69.4 [20.3]	66.8 [19.6]	
	Sens kBtu/h [kW]	51.0 [14.9]	46.9 [13.7]	42.3 [12.4]	65.4 [19.2]	60.1 [17.6]	54.3 [15.9]	71.8 [21.0]	66.9 [19.6]	60.5 [17.7]	
	Power	9.8	9.6	9.4	9.6	9.4	9.3	9.5	9.3	9.1	
125 [51.7]	Total kBtu/h [kW]	76.4 [22.4]	73.8 [21.6]	71.1 [20.8]	72.5 [21.2]	70.1 [20.5]	67.5 [19.8]	67.7 [19.8]	65.4 [19.2]	63.0 [18.5]	
	Sens kBtu/h [kW]	47.9 [14.0]	44.0 [12.9]	39.7 [11.6]	62.3 [18.3]	57.2 [16.8]	51.7 [15.2]	67.7 [19.8]	64.1 [18.8]	57.9 [17.0]	
	Power	10.1	9.9	9.7	9.9	9.7	9.6	9.8	9.6	9.4	

DR —Depression ratio
dbE —Entering air dry bulb
wbE—Entering air wet bulb

Total —Total capacity x 1000 Btu/h
Sens —Sensible capacity x 1000 Btu/h
Power—kW input

NOTES: ① When the entering air dry bulb is other than 80°F [27°C], adjust the sensible capacity from the table by adding [1.10 x CFM x (1 – DR) x (dbE – 80)].

[] Designates Metric Conversions

HEATING PERFORMANCE DATA—RHPDYB090

IDB		60°F [15.6°C]			70°F [21.1°C]			80°F [26.7°C]			
CFM [L/s]		3375 [1593]	3025 [1428]	2250 [1062]	3375 [1593]	3025 [1428]	2250 [1062]	3375 [1593]	3025 [1428]	2250 [1062]	
OUTDOOR DRY BULB TEMPERATURE	0 [-17.8]	Total kBtu/h [kW] Power	32.1 [9.4] 6.0	31.9 [9.3] 6.1	31.3 [9.2] 6.2	30.7 [9.0] 6.3	30.4 [8.9] 6.4	29.9 [8.8] 6.6	29.2 [8.6] 7.2	29.0 [8.5] 7.3	28.5 [8.4] 7.6
	5 [-15.0]	Total kBtu/h [kW] Power	37.9 [11.1] 6	37.6 [11.0] 6.1	36.9 [10.8] 6.3	36.5 [10.7] 6.3	36.2 [10.6] 6.4	35.5 [10.4] 6.6	35.1 [10.3] 7.3	34.8 [10.2] 7.4	34.1 [10.0] 7.6
	10 [-12.2]	Total kBtu/h [kW] Power	43.7 [12.8] 6.1	43.4 [12.7] 6.2	42.6 [12.5] 6.3	42.3 [12.4] 6.4	42.0 [12.3] 6.5	41.2 [12.1] 6.7	40.9 [12.0] 7.3	40.5 [11.9] 7.4	39.8 [11.7] 7.7
	15 [-9.4]	Total kBtu/h [kW] Power	49.6 [14.5] 6.1	49.2 [14.4] 6.2	48.3 [14.2] 6.4	48.1 [14.1] 6.4	47.7 [14.0] 6.5	46.8 [13.7] 6.8	46.7 [13.7] 7.4	46.3 [13.6] 7.5	45.4 [13.3] 7.7
	20 [-6.7]	Total kBtu/h [kW] Power	55.4 [16.2] 6.2	54.9 [16.1] 6.3	53.9 [15.8] 6.5	53.9 [15.8] 6.5	53.5 [15.7] 6.6	52.5 [15.4] 6.8	52.5 [15.4] 7.4	52.0 [15.2] 7.5	51.1 [15.0] 7.8
	25 [-3.9]	Total kBtu/h [kW] Power	61.2 [17.9] 6.2	60.7 [17.8] 6.3	59.6 [17.5] 6.5	59.7 [17.5] 6.5	59.2 [17.4] 6.6	58.2 [17.1] 6.9	58.3 [17.1] 7.5	57.8 [16.9] 7.6	56.8 [16.6] 7.8
	30 [-1.1]	Total kBtu/h [kW] Power	67.0 [19.6] 6.3	66.4 [19.5] 6.4	65.2 [19.1] 6.6	65.5 [19.2] 6.6	65.0 [19.1] 6.7	63.8 [18.7] 6.9	64.1 [18.8] 7.5	63.6 [18.6] 7.6	62.4 [18.3] 7.9
	35 [1.7]	Total kBtu/h [kW] Power	72.8 [21.3] 6.3	72.2 [21.2] 6.4	70.9 [20.8] 6.6	71.4 [20.9] 6.6	70.8 [20.8] 6.7	69.5 [20.4] 7.0	69.9 [20.5] 7.6	69.3 [20.3] 7.7	68.1 [20.0] 7.9
	40 [4.4]	Total kBtu/h [kW] Power	78.6 [23.0] 6.4	78.0 [22.9] 6.5	76.5 [22.4] 6.7	77.2 [22.6] 6.7	76.5 [22.4] 6.8	75.1 [22.0] 7.0	75.7 [22.2] 7.6	75.1 [22.0] 7.7	73.7 [21.6] 8.0
	45 [7.2]	Total kBtu/h [kW] Power	84.4 [24.7] 6.4	83.7 [24.5] 6.5	82.2 [24.1] 6.7	83.0 [24.3] 6.7	82.3 [24.1] 6.8	80.8 [23.7] 7.1	81.5 [23.9] 7.7	80.9 [23.7] 7.8	79.4 [23.3] 8.0
	50 [10.0]	Total kBtu/h [kW] Power	90.2 [26.4] 6.5	89.5 [26.2] 6.6	87.8 [25.7] 6.8	88.8 [26.0] 6.8	88.1 [25.8] 6.9	86.4 [25.3] 7.1	87.3 [25.6] 7.7	86.6 [25.4] 7.8	85.0 [24.9] 8.1

IDB—Indoor air dry bulb

[] Designates Metric Conversions

COOLING PERFORMANCE DATA—RHPDYB102

ENTERING INDOOR AIR @ 80°F [26.7°C] dbE ①											
wbE		71°F [21.7°C]			67°F [19.4°C]			63°F [17.2°C]			
CFM [L/s]		4075 [1923]	3350 [1581]	2700 [1274]	4075 [1923]	3350 [1581]	2700 [1274]	4075 [1923]	3350 [1581]	2700 [1274]	
DR ①		.05	.09	.12	.05	.09	.12	.05	.09	.12	
OUTDOOR DRY BULB TEMPERATURE °F [°C]	75 [23.9]	Total kBtu/h [kW] Sens kBtu/h [kW] Power	123.5 [36.2] 75.0 [22.0] 7.5	118.8 [34.8] 68.1 [20.0] 7.3	114.6 [33.6] 62.0 [18.2] 7.2	116.2 [34.1] 88.9 [26.1] 7.2	111.8 [32.8] 80.7 [23.7] 7.0	107.8 [31.6] 73.4 [21.5] 6.9	109.0 [31.9] 95.1 [27.9] 6.9	104.9 [30.7] 86.4 [25.3] 6.8	101.2 [29.7] 78.5 [23.0] 6.7
	80 [26.7]	Total kBtu/h [kW] Sens kBtu/h [kW] Power	121.2 [35.5] 74.4 [21.8] 7.7	116.6 [34.2] 67.5 [19.8] 7.6	112.5 [33.0] 61.4 [18.0] 7.5	113.9 [33.4] 88.2 [25.8] 7.5	109.6 [32.1] 80.1 [23.5] 7.3	105.7 [31.0] 72.9 [21.4] 7.2	106.8 [31.3] 94.4 [27.7] 7.2	102.7 [30.1] 85.8 [25.1] 7.1	99.1 [29.0] 78.0 [22.9] 6.9
	85 [29.4]	Total kBtu/h [kW] Sens kBtu/h [kW] Power	118.7 [34.8] 73.5 [21.5] 8.1	114.2 [33.5] 66.7 [19.5] 7.9	110.2 [32.3] 60.7 [17.8] 7.8	111.4 [32.6] 87.3 [25.6] 7.8	107.2 [31.4] 79.3 [23.2] 7.7	103.4 [30.3] 72.1 [21.1] 7.5	104.3 [30.6] 93.5 [27.4] 7.5	100.3 [29.4] 84.9 [24.9] 7.4	96.8 [28.4] 77.2 [22.6] 7.3
	90 [32.2]	Total kBtu/h [kW] Sens kBtu/h [kW] Power	115.9 [34.0] 72.3 [21.2] 8.5	111.6 [32.7] 65.7 [19.3] 8.3	107.6 [31.5] 59.7 [17.5] 8.2	108.6 [31.8] 86.1 [25.2] 8.2	104.5 [30.6] 78.2 [22.9] 8.0	100.8 [29.5] 71.2 [20.9] 7.9	101.5 [29.7] 92.3 [27.1] 7.9	97.6 [28.6] 83.9 [24.6] 7.8	94.2 [27.6] 76.3 [22.4] 7.6
	95 [35]	Total kBtu/h [kW] Sens kBtu/h [kW] Power	112.9 [33.1] 70.9 [20.8] 8.9	108.6 [31.8] 64.4 [18.9] 8.8	104.8 [30.7] 58.5 [17.1] 8.6	105.6 [30.9] 84.7 [24.8] 8.7	101.6 [29.8] 76.9 [22.5] 8.5	98.0 [28.7] 70.0 [20.5] 8.4	98.5 [28.9] 90.9 [26.6] 8.4	94.7 [27.8] 82.6 [24.2] 8.2	91.4 [26.8] 75.1 [22.0] 8.1
	100 [37.8]	Total kBtu/h [kW] Sens kBtu/h [kW] Power	109.6 [32.1] 69.2 [20.3] 9.5	105.5 [30.9] 62.8 [18.4] 9.3	101.8 [29.8] 57.1 [16.7] 9.1	102.3 [30.0] 83.0 [24.3] 9.2	98.5 [28.9] 75.4 [22.1] 9.0	95.0 [27.8] 68.6 [20.1] 8.8	95.2 [27.9] 89.2 [26.1] 8.9	91.6 [26.8] 81.0 [23.7] 8.7	88.3 [25.9] 73.7 [21.6] 8.6
	105 [40.6]	Total kBtu/h [kW] Sens kBtu/h [kW] Power	106.1 [31.1] 67.2 [19.7] 10.0	102.1 [29.9] 61.1 [17.9] 9.8	98.5 [28.9] 55.5 [16.3] 9.7	98.8 [29.0] 81.1 [23.8] 9.7	95.0 [27.8] 73.6 [21.6] 9.6	91.7 [26.9] 67.0 [19.6] 9.4	91.6 [26.8] 87.3 [25.6] 9.5	88.1 [25.8] 79.3 [23.2] 9.3	85.0 [24.9] 72.1 [21.1] 9.1
	110 [43.3]	Total kBtu/h [kW] Sens kBtu/h [kW] Power	102.2 [30.0] 65.0 [19.1] 10.6	98.4 [28.8] 59.1 [17.3] 10.4	94.9 [27.8] 53.7 [15.7] 10.3	94.9 [27.8] 78.9 [23.1] 10.4	91.3 [26.8] 71.6 [21.0] 10.2	88.1 [25.8] 65.2 [19.1] 10.0	87.8 [25.7] 85.1 [24.9] 10.1	84.5 [24.8] 77.3 [22.7] 9.9	81.5 [23.9] 70.3 [20.6] 9.7
	115 [46.1]	Total kBtu/h [kW] Sens kBtu/h [kW] Power	98.2 [28.8] 62.6 [18.3] 11.3	94.4 [27.7] 56.8 [16.6] 11.1	91.1 [26.7] 51.7 [15.2] 10.9	90.9 [26.6] 76.4 [22.4] 11.1	87.4 [25.6] 69.4 [20.3] 10.8	84.3 [24.7] 63.1 [18.5] 10.7	83.7 [24.5] 82.6 [24.2] 10.8	80.5 [23.6] 75.0 [22.0] 10.6	77.7 [22.8] 68.2 [20.0] 10.4
	120 [48.9]	Total kBtu/h [kW] Sens kBtu/h [kW] Power	93.8 [27.5] 59.8 [17.5] 12.1	90.3 [26.5] 54.3 [15.9] 11.8	87.1 [25.5] 49.4 [14.5] 11.6	86.5 [25.4] 73.7 [21.6] 11.8	83.2 [24.4] 66.9 [19.6] 11.6	80.3 [23.5] 60.9 [17.8] 11.4	79.3 [23.2] 79.3 [23.2] 11.5	76.3 [22.4] 72.6 [21.3] 11.3	73.7 [21.6] 66.0 [19.3] 11.1
	125 [51.7]	Total kBtu/h [kW] Sens kBtu/h [kW] Power	89.2 [26.1] 56.8 [16.6] 12.9	85.8 [25.1] 51.6 [15.1] 12.6	82.8 [24.3] 47.0 [13.8] 12.4	81.9 [24.0] 70.7 [20.7] 12.6	78.8 [23.1] 64.2 [18.8] 12.4	76.0 [22.3] 58.4 [17.1] 12.1	74.7 [21.9] 74.7 [21.9] 12.3	71.9 [21.1] 69.9 [20.5] 12.1	69.4 [20.3] 63.5 [18.6] 11.9

DR —Depression ratio
dbE —Entering air dry bulb
wbE —Entering air wet bulb

Total —Total capacity x 1000 Btu/h
Sens —Sensible capacity x 1000 Btu/h
Power —kW input

NOTES: ① When the entering air dry bulb is other than 80°F [27°C], adjust the sensible capacity from the table by adding [1.10 x CFM x (1 - DR) x (dbE - 80)].

[] Designates Metric Conversions

HEATING PERFORMANCE DATA—RHPDYB102

IDB		60°F [15.6°C]			70°F [21.1°C]			80°F [26.7°C]			
CFM [L/s]		3825 [1805]	3350 [1581]	2550 [1203]	3825 [1805]	3350 [1581]	2550 [1203]	3825 [1805]	3350 [1581]	2550 [1203]	
OUTDOOR DRY BULB TEMPERATURE °F [°C]	0 [-17.8]	Total kBtu/h [kW] Power	33.1 [9.7] 5.2	32.7 [9.6] 5.3	32.2 [9.4] 5.4	32.5 [9.5] 5.8	32.1 [9.4] 5.9	31.6 [9.3] 6.1	31.9 [9.3] 6.5	31.5 [9.2] 6.6	31.0 [9.1] 6.8
	5 [-15.0]	Total kBtu/h [kW] Power	39.9 [11.7] 5.4	39.5 [11.6] 5.5	38.8 [11.4] 5.7	39.3 [11.5] 6.1	38.9 [11.4] 6.2	38.2 [11.2] 6.4	38.7 [11.3] 6.7	38.3 [11.2] 6.9	37.7 [11.0] 7.1
	10 [-12.2]	Total kBtu/h [kW] Power	46.8 [13.7] 5.7	46.3 [13.6] 5.8	45.5 [13.3] 6.0	46.1 [13.5] 6.3	45.7 [13.4] 6.5	44.9 [13.2] 6.7	45.5 [13.3] 7.0	45.1 [13.2] 7.1	44.3 [13.0] 7.3
	15 [-9.4]	Total kBtu/h [kW] Power	53.6 [15.7] 5.9	53.1 [15.6] 6.0	52.2 [15.3] 6.2	53.0 [15.5] 6.6	52.5 [15.4] 6.7	51.6 [15.1] 6.9	52.4 [15.4] 7.2	51.9 [15.2] 7.3	51.0 [14.9] 7.6
	20 [-6.7]	Total kBtu/h [kW] Power	60.4 [17.7] 6.1	59.8 [17.5] 6.2	58.8 [17.2] 6.4	59.8 [17.5] 6.8	59.2 [17.4] 6.9	58.2 [17.1] 7.1	59.2 [17.4] 7.4	58.6 [17.2] 7.5	57.6 [16.9] 7.8
	25 [-3.9]	Total kBtu/h [kW] Power	67.3 [19.7] 6.3	66.6 [19.5] 6.4	65.5 [19.2] 6.6	66.7 [19.5] 6.9	66.0 [19.3] 7.0	64.9 [19.0] 7.3	66.1 [19.4] 7.6	65.4 [19.2] 7.7	64.3 [18.8] 7.9
	30 [-1.1]	Total kBtu/h [kW] Power	74.1 [21.7] 6.4	73.4 [21.5] 6.5	72.1 [21.1] 6.7	73.5 [21.5] 7.1	72.8 [21.3] 7.2	71.5 [21.0] 7.4	72.9 [21.4] 7.7	72.2 [21.2] 7.8	70.9 [20.8] 8.1
	35 [1.7]	Total kBtu/h [kW] Power	81.0 [23.7] 6.5	80.1 [23.5] 6.6	78.8 [23.1] 6.8	80.4 [23.6] 7.2	79.5 [23.3] 7.3	78.2 [22.9] 7.5	79.7 [23.4] 7.8	78.9 [23.1] 7.9	77.6 [22.7] 8.2
	40 [4.4]	Total kBtu/h [kW] Power	87.8 [25.7] 6.6	86.9 [25.5] 6.7	85.4 [25.0] 6.9	87.2 [25.6] 7.2	86.3 [25.3] 7.4	84.8 [24.9] 7.6	86.6 [25.4] 7.9	85.7 [25.1] 8.0	84.3 [24.7] 8.3
	45 [7.2]	Total kBtu/h [kW] Power	94.6 [27.7] 6.6	93.7 [27.5] 6.7	92.1 [27.0] 6.9	94.0 [27.5] 7.3	93.1 [27.3] 7.4	91.5 [26.8] 7.6	93.4 [27.4] 7.9	92.5 [27.1] 8.1	90.9 [26.6] 8.3
	50 [10.0]	Total kBtu/h [kW] Power	101.5 [29.7] 6.6	100.5 [29.5] 6.8	98.7 [28.9] 7.0	100.9 [29.6] 7.3	99.9 [29.3] 7.4	98.2 [28.8] 7.6	100.3 [29.4] 7.9	99.3 [29.1] 8.1	97.6 [28.6] 8.3

IDB—Indoor air dry bulb

[] Designates Metric Conversions

COOLING PERFORMANCE DATA—RHPDYB120

ENTERING INDOOR AIR @ 80°F [26.7°C] dbE ①											
wbE		71°F [21.7°C]			67°F [19.4°C]			63°F [17.2°C]			
CFM [L/s]		4775 [2254]	3900 [1841]	3175 [1498]	4775 [2254]	3900 [1841]	3175 [1498]	4775 [2254]	3900 [1841]	3175 [1498]	
DR ①		.05	.09	.12	.05	.09	.12	.05	.09	.12	
OUTDOOR DRY BULB TEMPERATURE °F [°C]	75 [23.9]	Total kBtu/h [kW] Sens kBtu/h [kW] Power	145.4 [42.6] 90.9 [26.6] 9.1	139.7 [40.9] 82.3 [24.1] 8.9	135.0 [39.6] 75.1 [22.0] 8.8	136.7 [40.1] 98.4 [28.8] 9.1	131.4 [38.5] 89.1 [26.1] 8.9	126.9 [37.2] 81.3 [23.8] 8.8	128.1 [37.5] 106.0 [31.1] 9.0	123.1 [36.1] 95.9 [28.1] 8.8	118.9 [34.8] 87.6 [25.7] 8.7
	80 [26.7]	Total kBtu/h [kW] Sens kBtu/h [kW] Power	142.8 [41.9] 90.8 [26.6] 9.6	137.2 [40.2] 82.2 [24.1] 9.4	132.6 [38.9] 75.1 [22.0] 9.2	134.1 [39.3] 98.3 [28.8] 9.6	128.9 [37.8] 89.0 [26.1] 9.4	124.5 [36.5] 81.3 [23.8] 9.2	125.5 [36.8] 105.9 [31.0] 9.5	120.6 [35.3] 95.9 [28.1] 9.3	116.5 [34.1] 87.6 [25.7] 9.2
	85 [29.4]	Total kBtu/h [kW] Sens kBtu/h [kW] Power	139.9 [41.0] 90.4 [26.5] 10.1	134.4 [39.4] 81.8 [24.0] 9.9	129.9 [38.1] 74.7 [21.9] 9.7	131.1 [38.4] 97.9 [28.7] 10.1	126.0 [36.9] 88.6 [26.0] 9.9	121.7 [35.7] 80.9 [23.7] 9.7	122.5 [35.9] 105.5 [30.9] 10.0	117.7 [34.5] 95.5 [28.0] 9.8	113.7 [33.3] 87.2 [25.6] 9.6
	90 [32.2]	Total kBtu/h [kW] Sens kBtu/h [kW] Power	136.5 [40.0] 89.6 [26.3] 10.6	131.2 [38.5] 81.1 [23.8] 10.4	126.8 [37.2] 74.0 [21.7] 10.2	127.8 [37.5] 97.1 [28.5] 10.5	122.8 [36.0] 87.9 [25.8] 10.3	118.7 [34.8] 80.2 [23.5] 10.2	119.2 [34.9] 104.7 [30.7] 10.5	114.5 [33.6] 94.7 [27.8] 10.3	110.7 [32.4] 86.5 [25.4] 10.1
	95 [35]	Total kBtu/h [kW] Sens kBtu/h [kW] Power	132.9 [39.0] 88.4 [25.9] 11.1	127.6 [37.4] 80.0 [23.4] 10.8	123.3 [36.1] 73.0 [21.4] 10.7	124.1 [36.4] 95.8 [28.1] 11.0	119.3 [35.0] 86.8 [25.4] 10.8	115.2 [33.8] 79.2 [23.2] 10.6	115.5 [33.9] 103.5 [30.3] 11.0	111.0 [32.5] 93.6 [27.4] 10.8	107.2 [31.4] 85.5 [25.1] 10.6
	100 [37.8]	Total kBtu/h [kW] Sens kBtu/h [kW] Power	128.8 [37.7] 86.8 [25.4] 11.5	123.7 [36.3] 78.5 [23.0] 11.3	119.6 [35.1] 71.7 [21.0] 11.1	120.1 [35.2] 94.2 [27.6] 11.5	115.4 [33.8] 85.3 [25.0] 11.3	111.5 [32.7] 77.9 [22.8] 11.1	111.4 [32.6] 101.9 [29.9] 11.5	107.1 [31.4] 92.2 [27.0] 11.2	103.5 [30.3] 84.2 [24.7] 11.0
	105 [40.6]	Total kBtu/h [kW] Sens kBtu/h [kW] Power	124.4 [36.5] 84.8 [24.9] 12.0	119.5 [35.0] 76.7 [22.5] 11.8	115.5 [33.9] 70.1 [20.5] 11.6	115.6 [33.9] 92.3 [27.1] 12.0	111.1 [32.6] 83.5 [24.5] 11.8	107.4 [31.5] 76.3 [22.4] 11.6	107.0 [31.4] 99.9 [29.3] 11.9	102.8 [30.1] 90.4 [26.5] 11.7	99.4 [29.1] 82.6 [24.2] 11.5
	110 [43.3]	Total kBtu/h [kW] Sens kBtu/h [kW] Power	119.6 [35.1] 82.4 [24.2] 12.5	114.9 [33.7] 74.6 [21.9] 12.3	111.0 [32.5] 68.1 [20.0] 12.1	110.9 [32.5] 89.9 [26.3] 12.5	106.5 [31.2] 81.4 [23.9] 12.3	102.9 [30.2] 74.3 [21.8] 12.1	102.2 [30.0] 97.5 [28.6] 12.4	98.2 [28.8] 88.3 [25.9] 12.2	94.9 [27.8] 80.6 [23.6] 12.0
	115 [46.1]	Total kBtu/h [kW] Sens kBtu/h [kW] Power	114.4 [33.5] 79.6 [23.3] 13.0	110.0 [32.2] 72.1 [21.1] 12.8	106.2 [31.1] 65.8 [19.3] 12.5	105.7 [31.0] 87.1 [25.5] 13.0	101.6 [29.8] 78.9 [23.1] 12.7	98.1 [28.8] 72.0 [21.1] 12.5	97.1 [28.5] 94.7 [27.8] 12.9	93.3 [27.3] 85.8 [25.1] 12.7	90.1 [26.4] 78.3 [22.9] 12.5
	120 [48.9]	Total kBtu/h [kW] Sens kBtu/h [kW] Power	108.9 [31.9] 76.5 [22.4] 13.5	104.7 [30.7] 69.3 [20.3] 13.2	101.1 [29.6] 63.2 [18.5] 13.0	100.2 [29.4] 84.0 [24.6] 13.5	96.3 [28.2] 76.0 [22.3] 13.2	93.0 [27.3] 69.4 [20.3] 13.0	91.6 [26.8] 91.6 [26.8] 13.4	88.0 [25.8] 82.9 [24.3] 13.1	85.0 [24.9] 75.7 [22.2] 12.9
125 [51.7]	Total kBtu/h [kW] Sens kBtu/h [kW] Power	103.1 [30.2] 73.0 [21.4] 14.0	99.0 [29.0] 66.1 [19.4] 13.7	95.7 [28.0] 60.3 [17.7] 13.5	94.3 [27.6] 80.5 [23.6] 14.0	90.6 [26.6] 72.8 [21.3] 13.7	87.6 [25.7] 66.5 [19.5] 13.5	85.7 [25.1] 85.7 [25.1] 13.9	82.4 [24.2] 79.7 [23.4] 13.6	79.6 [23.3] 72.8 [21.3] 13.4	

DR —Depression ratio
dbE —Entering air dry bulb
wbE —Entering air wet bulb

Total —Total capacity x 1000 Btu/h
Sens —Sensible capacity x 1000 Btu/h
Power —kW input

NOTES: ① When the entering air dry bulb is other than 80°F [27°C], adjust the sensible capacity from the table by adding [1.10 x CFM x (1 - DR) x (dbE - 80)].

[] Designates Metric Conversions

HEATING PERFORMANCE DATA—RHPDYB120

IDB		60°F [15.6°C]			70°F [21.1°C]			80°F [26.7°C]			
CFM [L/s]		4575 [2159]	3900 [1841]	3050 [1439]	4575 [2159]	3900 [1841]	3050 [1439]	4575 [2159]	3900 [1841]	3050 [1439]	
OUTDOOR DRY BULB TEMPERATURE	0 [-17.8]	Total kBtu/h [kW] Power	43.8 [12.8] 6.4	43.3 [12.7] 6.5	42.6 [12.5] 6.7	41.7 [12.2] 7.1	41.2 [12.1] 7.3	40.5 [11.9] 7.5	39.6 [11.6] 7.8	39.1 [11.5] 8.0	38.5 [11.3] 8.2
	5 [-15.0]	Total kBtu/h [kW] Power	51.7 [15.2] 6.6	51.1 [15.0] 6.7	50.3 [14.7] 6.9	49.6 [14.5] 7.3	49.0 [14.4] 7.5	48.2 [14.1] 7.7	47.5 [13.9] 8.0	46.9 [13.7] 8.2	46.2 [13.5] 8.4
	10 [-12.2]	Total kBtu/h [kW] Power	59.6 [17.5] 6.8	58.9 [17.3] 6.9	58.0 [17.0] 7.1	57.5 [16.9] 7.5	56.8 [16.6] 7.7	55.9 [16.4] 7.9	55.4 [16.2] 8.2	54.7 [16.0] 8.4	53.9 [15.8] 8.6
	15 [-9.4]	Total kBtu/h [kW] Power	67.5 [19.8] 6.9	66.7 [19.5] 7.1	65.7 [19.3] 7.3	65.4 [19.2] 7.7	64.6 [18.9] 7.9	63.6 [18.6] 8.1	63.3 [18.6] 8.4	62.5 [18.3] 8.6	61.6 [18.1] 8.8
	20 [-6.7]	Total kBtu/h [kW] Power	75.4 [22.1] 7.1	74.5 [21.8] 7.3	73.4 [21.5] 7.5	73.3 [21.5] 7.9	72.4 [21.2] 8.1	71.3 [20.9] 8.3	71.2 [20.9] 8.6	70.3 [20.6] 8.8	69.2 [20.3] 9.0
	25 [-3.9]	Total kBtu/h [kW] Power	83.3 [24.4] 7.3	82.3 [24.1] 7.5	81.0 [23.7] 7.7	81.2 [23.8] 8.1	80.2 [23.5] 8.2	79.0 [23.2] 8.5	79.1 [23.2] 8.8	78.2 [22.9] 9.0	76.9 [22.5] 9.2
	30 [-1.1]	Total kBtu/h [kW] Power	91.3 [26.8] 7.5	90.1 [26.4] 7.7	88.7 [26.0] 7.9	89.1 [26.1] 8.3	88.1 [25.8] 8.4	86.7 [25.4] 8.7	87.0 [25.5] 9.0	86.0 [25.2] 9.2	84.6 [24.8] 9.4
	35 [1.7]	Total kBtu/h [kW] Power	99.2 [29.1] 7.7	98.0 [28.7] 7.9	96.4 [28.3] 8.1	97.1 [28.5] 8.4	95.9 [28.1] 8.6	94.4 [27.7] 8.9	94.9 [27.8] 9.1	93.8 [27.5] 9.3	92.3 [27.1] 9.6
	40 [4.4]	Total kBtu/h [kW] Power	107.1 [31.4] 7.9	105.8 [31.0] 8.1	104.1 [30.5] 8.3	105.0 [30.8] 8.6	103.7 [30.4] 8.8	102.1 [29.9] 9.1	102.8 [30.1] 9.3	101.6 [29.8] 9.5	100.0 [29.3] 9.8
	45 [7.2]	Total kBtu/h [kW] Power	115.0 [33.7] 8.1	113.6 [33.3] 8.2	111.8 [32.8] 8.5	112.9 [33.1] 8.8	111.5 [32.7] 9.0	109.8 [32.2] 9.3	110.8 [32.5] 9.5	109.4 [32.1] 9.7	107.7 [31.6] 10.0
	50 [10.0]	Total kBtu/h [kW] Power	122.9 [36.0] 8.3	121.4 [35.6] 8.4	119.5 [35.0] 8.7	120.8 [35.4] 9.0	119.3 [35.0] 9.2	117.4 [34.4] 9.5	118.7 [34.8] 9.7	117.2 [34.3] 9.9	115.4 [33.8] 10.2

IDB—Indoor air dry bulb

[] Designates Metric Conversions

AIRFLOW PERFORMANCE— 7.5 TON [26.4 kW] — 60 Hz — DOWNFLOW

Air Flow CFM [L/s]	Model RHPDYB090 Voltage 208/230, 460, 575 — 3 phase 60 Hz																																								
	External Static Pressure—Inches of Water [kPa]																																								
	0.1 [.02]	0.2 [.05]	0.3 [.07]	0.4 [.10]	0.5 [.12]	0.6 [.15]	0.7 [.17]	0.8 [.20]	0.9 [.22]	1.0 [.25]	1.1 [.27]	1.2 [.30]	1.3 [.32]	1.4 [.35]	1.5 [.37]	1.6 [.40]	1.7 [.42]	1.8 [.45]	1.9 [.47]	2.0 [.50]																					
2400 [1133]	—	—	—	567	800	803	833	870	870	870	911	955	739	1003	772	1055	803	1111	835	1170	865	1233	895	1300	925	1370	954	1444	982	1522	1009	1604	1036	1689	1063	1779					
2500 [1180]	—	—	—	575	827	610	862	645	900	678	942	712	987	744	1036	776	1089	808	1146	838	1207	869	1271	898	1339	927	1411	955	1486	983	1565	1010	1648	1037	1735	1062	1825				
2600 [1227]	—	—	—	548	825	583	857	618	892	652	932	685	975	718	1022	750	1072	781	1127	812	1185	843	1246	872	1312	901	1381	930	1454	958	1531	985	1611	1011	1695	1037	1783	1063	1875		
2700 [1274]	—	—	—	557	856	591	889	626	926	659	966	692	1011	724	1059	756	1111	787	1166	817	1226	847	1289	876	1355	905	1426	933	1500	960	1578	987	1660	1013	1745	1038	1834	1063	1927		
2800 [1321]	—	—	—	566	890	600	924	634	962	667	1004	699	1049	731	1099	762	1152	793	1209	822	1269	852	1333	880	1401	909	1473	936	1549	963	1628	989	1711	1015	1797	1040	1888	1064	1982		
2900 [1368]	—	—	—	576	926	609	962	642	1001	675	1044	707	1091	738	1141	769	1196	799	1254	828	1315	857	1381	885	1450	913	1523	940	1600	966	1680	992	1764	1017	1852	1041	1944	1065	2039		
3000 [1416]	—	—	—	552	932	586	965	619	1002	651	1042	683	1087	715	1135	745	1187	776	1242	805	1301	834	1364	862	1431	890	1502	917	1576	944	1654	969	1735	995	1821	1019	1910	1043	2003	1066	2099
3100 [1463]	—	—	—	562	972	596	1007	629	1045	661	1087	692	1132	723	1181	753	1234	783	1291	812	1352	840	1416	868	1484	895	1556	922	1631	948	1710	973	1793	998	1880	1022	1970	1045	2064	1068	2162
3200 [1510]	—	—	—	574	1015	606	1051	639	1090	670	1133	701	1180	732	1231	761	1285	791	1343	819	1405	847	1470	874	1540	901	1612	927	1689	952	1770	977	1854	1002	1942	1025	2033	1048	2129	1070	2228
3300 [1557]	552	1028	585	1061	617	1098	649	1139	680	1183	711	1231	741	1283	770	1338	799	1398	827	1461	854	1527	881	1598	907	1672	933	1750	957	1831	982	1917	1005	2006	1029	2099	1051	2195	1073	2296	
3400 [1604]	564	1075	597	1110	629	1148	660	1190	691	1235	721	1284	750	1337	779	1394	807	1455	834	1519	861	1587	888	1659	913	1734	938	1813	963	1896	987	1983	1010	2073	1032	2167	1054	2265	1076	2367	
3500 [1652]	577	1125	609	1161	640	1200	671	1243	701	1290	731	1340	760	1395	788	1453	815	1514	843	1580	869	1649	895	1722	920	1799	944	1879	968	1963	992	2051	1014	2143	1037	2238	1058	2337	1079	2440	
3600 [1699]	590	1178	621	1215	652	1255	683	1293	712	1347	741	1399	770	1455	797	1514	824	1577	851	1644	877	1714	902	1788	927	1866	951	1948	974	2033	997	2122	1019	2215	1041	2312	1062	2412	1082	2516	

NOTE: F-Drive left of the bold line, G-Drive right of bold lines, H-Drive right of double line.

Drive Package	F					G					H							
Motor H.P. [W]	2 [1491.4]					3 [2237.1]					3 [2237.1]							
Blower Sheave	AK84H					AK84H					AK84H							
Motor Sheave	1VL40					1VP50					1VP56							
Belt	A49					A50					A51							
Turns Open	0	1	2	3	4	5	0	1	2	3	4	5	0	1	2	3	4	5
RPM	766	722	677	634	591	544	990	948	906	864	822	779	1109	1069	1029	988	948	906

- NOTES:**
1. Do not set motor sheave below minimum or maximum turns open shown.
 2. Re-adjustment of sheave required to achieve rated airflow at AHRI minimum External Static Pressure
 3. Drive data shown is for horizontal airflow with dry coil. Add component resistance (below) to duct resistance to determine total External Static Pressure.
 4. Factory sheave settings are shown in bold type.

[] Designates Metric Conversions

AIRFLOW PERFORMANCE— 7.5 TON [26.4 kW] — 60 Hz — DOWNFLOW (CONTINUED)

Airflow CFM [L/s]	AIRFLOW CORRECTION FACTORS *			COMPONENT AIRFLOW RESISTANCE					Pressure Drop MERV 13
	Total kBtu/h	Sensible kBtu/h	Power kW	Wet Coil	Vertical Economizer RA Damper Open	Resistance — Inches of Water		Pressure Drop MERV 8	
						Concentric Diffuser RXRN-AEF2000 & Concentric Adapter RXMC-DD01 (Flush)	Concentric Diffuser RXRN-AED2000 & Concentric Adapter RXMC-DD01 (Drop)		
2400 [1133]	0.97	0.92	0.99	0.06 [.01]	0.01 [.00]	0.66 [.16]	0.53 [.13]	0.093 [.02]	0.047 [.01]
2500 [1180]	0.98	0.93	0.99	0.06 [.01]	0.02 [.00]	0.71 [.18]	0.57 [.14]	0.098 [.02]	0.055 [.01]
2600 [1227]	0.99	0.95	0.99	0.06 [.02]	0.02 [.01]	0.75 [.19]	0.60 [.15]	0.103 [.02]	0.062 [.01]
2700 [1274]	0.99	0.96	0.99	0.07 [.02]	0.03 [.01]	0.80 [.20]	0.65 [.16]	0.108 [.03]	0.070 [.02]
2800 [1321]	0.99	0.98	1.00	0.07 [.02]	0.04 [.01]	0.85 [.21]	0.69 [.17]	0.113 [.03]	0.078 [.02]
2900 [1368]	1.00	1.00	1.00	0.08 [.02]	0.04 [.01]	0.91 [.23]	0.74 [.18]	0.117 [.03]	0.085 [.02]
3000 [1416]	1.01	1.01	1.00	0.08 [.02]	0.05 [.01]	0.96 [.24]	0.79 [.20]	0.122 [.03]	0.093 [.02]
3100 [1463]	1.01	1.03	1.00	0.09 [.02]	0.06 [.02]	1.02 [.25]	0.86 [.21]	0.127 [.03]	0.100 [.02]
3200 [1510]	1.02	1.04	1.01	0.10 [.02]	0.07 [.02]	1.08 [.27]	0.92 [.23]	0.132 [.03]	0.108 [.03]
3300 [1557]	1.02	1.06	1.01	0.10 [.03]	0.08 [.02]	1.15 [.29]	0.99 [.25]	0.137 [.03]	0.115 [.03]
3400 [1604]	1.03	1.08	1.01	0.11 [.03]	0.09 [.02]	1.21 [.30]	1.05 [.26]	0.142 [.03]	0.123 [.03]
3500 [1652]	1.04	1.09	1.01	0.11 [.03]	0.10 [.02]	1.29 [.32]	1.09 [.27]	0.147 [.04]	0.131 [.03]
3600 [1699]	1.04	1.11	1.02	0.12 [.03]	0.11 [.03]	1.36 [.34]	1.13 [.28]	0.152 [.04]	0.138 [.03]

*Multiply correction factor times gross performance data resulting sensible capacity cannot exceed total capacity.

[] Designates Metric Conversions

AIRFLOW PERFORMANCE— 7.5 TON [26.4 kW] — 60 Hz — SIDEFLOW (CONTINUED)

Airflow CFM [L/s]	AIRFLOW CORRECTION FACTORS *			COMPONENT AIRFLOW RESISTANCE					Pressure Drop MERV 13
	Total kBtu/h	Sensible kBtu/h	Power kW	Wet Coil	Horizontal Economizer RA Damper Open	Resistance — Inches of Water		Pressure Drop MERV 8	
						Concentric Diffuser RXRN-AEF2000 & Concentric Adapter RXMC-DD01 (Flush)	Concentric Diffuser RXRN-AED2000 & Concentric Adapter RXMC-DD01 (Drop)		
2400 [1133]	0.97	0.92	0.99	0.06 [.01]	0.21 [0.05]	0.66 [.16]	0.53 [.13]	0.093 [.02]	0.047 [.01]
2500 [1180]	0.97	0.93	0.99	0.06 [.01]	0.25 [0.06]	0.71 [.18]	0.57 [.14]	0.098 [.02]	0.055 [.01]
2600 [1227]	0.98	0.95	0.99	0.06 [.02]	0.28 [0.07]	0.75 [.19]	0.60 [.15]	0.103 [.02]	0.062 [.01]
2700 [1274]	0.99	0.96	0.99	0.07 [.02]	0.32 [0.08]	0.80 [.20]	0.65 [.16]	0.108 [.03]	0.070 [.02]
2800 [1321]	0.99	0.98	1.00	0.07 [.02]	0.36 [0.09]	0.85 [.21]	0.69 [.17]	0.113 [.03]	0.078 [.02]
2900 [1368]	1.00	1.00	1.00	0.08 [.02]	0.39 [0.10]	0.91 [.23]	0.74 [.18]	0.117 [.03]	0.085 [.02]
3000 [1416]	1.01	1.01	1.00	0.08 [.02]	0.43 [0.11]	0.96 [.24]	0.79 [.20]	0.122 [.03]	0.093 [.02]
3100 [1463]	1.01	1.03	1.00	0.09 [.02]	0.47 [0.12]	1.02 [.25]	0.86 [.21]	0.127 [.03]	0.100 [.02]
3200 [1510]	1.02	1.04	1.01	0.10 [.02]	0.51 [0.13]	1.08 [.27]	0.92 [.23]	0.132 [.03]	0.108 [.03]
3300 [1557]	1.02	1.06	1.01	0.10 [.03]	0.54 [0.14]	1.15 [.29]	0.99 [.25]	0.137 [.03]	0.115 [.03]
3400 [1604]	1.03	1.08	1.01	0.11 [.03]	0.58 [0.14]	1.21 [.30]	1.05 [.26]	0.142 [.03]	0.123 [.03]
3500 [1652]	1.04	1.09	1.01	0.11 [.03]	0.62 [0.15]	1.29 [.32]	1.09 [.27]	0.147 [.04]	0.131 [.03]
3600 [1699]	1.04	1.11	1.02	0.12 [.03]	0.66 [0.16]	1.36 [.34]	1.13 [.28]	0.152 [.04]	0.138 [.03]

*Multiply correction factor times gross performance data resulting sensible capacity cannot exceed total capacity.

[] Designates Metric Conversions

AIRFLOW PERFORMANCE—8.5 TON [29.9 kW] — 60 Hz — DOWNFLOW (CONTINUED)

Airflow CFM [L/s]	AIRFLOW CORRECTION FACTORS *		COMPONENT AIRFLOW RESISTANCE					Pressure Drop MERV 13	
	Total kBtu/h	Sensible kBtu/h	Power kW	Wet Coil	Vertical Economizer RA Damper Open	Resistance — Inches of Water			Pressure Drop MERV 8
						Concentric Diffuser RXRN-AEF2000 & Concentric Adapter RXMC-DD01 (Flush)	Concentric Diffuser RXRN-AED2000 & Concentric Adapter RXMC-DD01 (Drop)		
2400 [1133]	0.97	0.92	0.99	0.06 [.01]	0.21 [0.05]	0.66 [.16]	0.53 [.13]	0.093 [.02]	0.047 [.01]
2500 [1180]	0.97	0.93	0.99	0.06 [.01]	0.25 [0.06]	0.71 [.18]	0.57 [.14]	0.098 [.02]	0.055 [.01]
2600 [1227]	0.98	0.95	0.99	0.06 [.02]	0.28 [0.07]	0.75 [.19]	0.60 [.15]	0.103 [.02]	0.062 [.01]
2700 [1274]	0.99	0.96	0.99	0.07 [.02]	0.32 [0.08]	0.80 [.20]	0.65 [.16]	0.108 [.03]	0.070 [.02]
2800 [1321]	0.99	0.98	1.00	0.07 [.02]	0.36 [0.09]	0.85 [.21]	0.69 [.17]	0.113 [.03]	0.078 [.02]
2900 [1368]	1.00	1.00	1.00	0.08 [.02]	0.39 [0.10]	0.91 [.23]	0.74 [.18]	0.117 [.03]	0.085 [.02]
3000 [1416]	1.01	1.01	1.00	0.08 [.02]	0.43 [0.11]	0.96 [.24]	0.79 [.20]	0.122 [.03]	0.093 [.02]
3100 [1463]	1.01	1.03	1.00	0.09 [.02]	0.47 [0.12]	1.02 [.25]	0.86 [.21]	0.127 [.03]	0.100 [.02]
3200 [1510]	1.02	1.04	1.01	0.10 [.02]	0.51 [0.13]	1.08 [.27]	0.92 [.23]	0.132 [.03]	0.108 [.03]
3300 [1557]	1.02	1.06	1.01	0.10 [.03]	0.54 [0.14]	1.15 [.29]	0.99 [.25]	0.137 [.03]	0.115 [.03]
3400 [1604]	1.03	1.08	1.01	0.11 [.03]	0.58 [0.14]	1.21 [.30]	1.05 [.26]	0.142 [.03]	0.123 [.03]
3500 [1652]	1.04	1.09	1.01	0.11 [.03]	0.62 [0.15]	1.29 [.32]	1.09 [.27]	0.147 [.04]	0.131 [.03]
3600 [1699]	1.04	1.11	1.02	0.12 [.03]	0.66 [0.16]	1.36 [.34]	1.13 [.28]	0.152 [.04]	0.138 [.03]

*Multiply correction factor times gross performance data resulting sensible capacity cannot exceed total capacity.

[] Designates Metric Conversions

AIRFLOW PERFORMANCE—8.5 TON [29.9 kW] — 60 Hz — SIDEFLOW

Air Flow CFM [L/s]	Model RHPDYB102 Voltage 208/230, 460, 575 — 3 phase 60 Hz																																									
	External Static Pressure—Inches of Water [kPa]																																									
	0.1 [0.02]	0.2 [0.05]	0.3 [0.07]	0.4 [0.10]	0.5 [0.12]	0.6 [0.15]	0.7 [0.17]	0.8 [0.20]	0.9 [0.22]	1.0 [0.25]	1.1 [0.27]	1.2 [0.30]	1.3 [0.32]	1.4 [0.35]	1.5 [0.37]	1.6 [0.40]	1.7 [0.42]	1.8 [0.45]	1.9 [0.47]	2.0 [0.50]																						
2700 [1274]	—	—	—	—	583	707	613	760	643	815	673	874	703	935	733	998	762	1065	792	1134	821	1206	850	1280	879	1358	908	1438	937	1520	966	1606	995	1694	1023	1785						
2800 [1321]	—	—	—	—	569	688	589	740	618	794	648	852	677	912	706	974	736	1040	765	1108	794	1179	823	1252	851	1329	880	1408	908	1490	937	1574	965	1661	993	1751	1021	1844				
2900 [1368]	—	—	—	—	565	722	594	776	623	832	653	891	681	953	710	1017	739	1084	768	1154	796	1227	825	1302	853	1381	881	1461	909	1545	937	1631	965	1720	992	1812	1020	1906				
3000 [1416]	—	—	—	—	572	759	600	815	629	873	658	934	686	997	715	1064	743	1133	771	1204	799	1279	827	1356	855	1436	882	1518	910	1604	937	1692	965	1782	992	1876	1019	1972				
3100 [1463]	—	—	—	—	579	800	607	857	635	917	663	980	691	1045	719	1113	747	1188	775	1257	802	1334	830	1412	857	1494	884	1579	911	1666	938	1755	965	1848	992	1943	1018	2041				
3200 [1510]	—	—	—	—	568	788	586	844	614	903	642	965	669	1029	697	1096	724	1166	751	1238	779	1314	806	1392	833	1472	860	1556	886	1642	913	1731	939	1822	966	1917	992	2014	1018	2114		
3300 [1557]	—	—	—	—	566	833	594	891	621	952	648	1016	676	1082	703	1151	730	1222	756	1296	783	1373	810	1453	836	1536	862	1621	889	1709	915	1799	941	1893	967	1989	993	2088	1018	2189		
3400 [1604]	—	—	—	—	557	876	584	934	610	996	637	1060	663	1127	689	1197	715	1269	741	1344	767	1422	793	1503	819	1586	844	1672	870	1761	895	1852	920	1946	945	2043	970	2143	995	2245	1020	2350
3500 [1652]	—	—	—	—	567	929	593	990	619	1053	645	1119	671	1188	697	1259	722	1334	748	1411	773	1490	799	1572	824	1658	849	1745	874	1836	899	1929	923	2025	948	2124	972	2225	997	2329	1021	2436
3600 [1699]	—	—	—	—	577	986	603	1049	628	1114	654	1182	679	1252	705	1325	730	1401	755	1480	780	1561	804	1645	829	1732	854	1822	878	1914	903	2009	927	2107	951	2207	975	2310	999	2416	1023	2525
3700 [1746]	—	—	—	—	588	1047	613	1111	638	1178	663	1247	688	1319	713	1394	737	1472	762	1553	786	1636	811	1722	835	1810	859	1902	883	1996	907	2092	931	2192	954	2294	978	2399	1001	2507	1025	2617
3800 [1793]	562	985	588	1047	613	1111	638	1178	663	1247	688	1319	713	1394	737	1472	762	1553	786	1636	811	1722	835	1810	859	1902	883	1996	907	2092	931	2192	954	2294	978	2399	1001	2507	1025	2617		
3900 [1840]	574	1047	599	1110	623	1176	648	1245	673	1316	697	1390	721	1467	746	1546	770	1629	794	1714	817	1801	841	1892	865	1985	888	2081	912	2179	935	2280	958	2384	981	2491	1004	2600	1027	2713		
4000 [1888]	586	1112	610	1177	634	1245	658	1315	683	1388	706	1464	730	1543	754	1624	778	1708	801	1795	824	1884	848	1976	871	2071	894	2169	917	2269	940	2372	962	2478	985	2586	1007	2697	1030	2811		
4100 [1935]	598	1181	622	1248	645	1317	669	1389	693	1464	716	1542	740	1622	763	1705	786	1791	809	1879	832	1970	855	2064	877	2161	900	2260	922	2362	945	2467	967	2575	989	2685	1011	2798	1033	2913		

NOTE: F-Drive left of the bold line, G-Drive right of bold lines, H-Drive right of double line.

Drive Package	F					G					H							
Motor H.P. [W]	2 [1491.4]					3 [2237.1]					3 [2237.1]							
Blower Sheave	AK84H					AK84H					AK84H							
Motor Sheave	1VP40					1VP50					1VP56							
Belt	A49					A50					A51							
Turns Open	0	1	2	3	4	5	0	1	2	3	4	5	0	1	2	3	4	5
RPM	765	724	684	641	598	557	970	942	898	861	821	779	—	1045	1017	981	942	902

- NOTES: 1. Do not set motor sheave below minimum or maximum turns open shown.
 2. Re-adjustment of sheave required to achieve rated airflow at AHRI minimum External Static Pressure
 3. Drive data shown is for horizontal airflow with dry coil. Add component resistance (below) to duct resistance to determine total External Static Pressure.
 4. Factory sheave settings are shown in bold type.

[] Designates Metric Conversions

AIRFLOW PERFORMANCE—8.5 TON [29.9 kW] — 60 Hz — SIDEFLOW (CONTINUED)

Airflow CFM [L/s]	AIRFLOW CORRECTION FACTORS *			COMPONENT AIRFLOW RESISTANCE					
	Total kBtu/h	Sensible kBtu/h	Power kW	Wet Coil	Vertical Economizer RA Damper Open	Concentric Diffuser RXRN-AEF2000 & Concentric Adapter RXMC-DD01 (Flush)	Concentric Diffuser RXRN-AED2000 & Concentric Adapter RXMC-DD01 (Drop)	Pressure Drop MERV 8	Pressure Drop MERV 13
	Resistance — Inches of Water [kPa]								
2700 [1274]	0.99	0.96	0.99	0.07 [.02]	0.32 [0.08]	0.80 [.20]	0.65 [.16]	0.108 [.03]	0.070 [.02]
2800 [1321]	0.99	0.98	1.00	0.07 [.02]	0.36 [0.09]	0.85 [.21]	0.69 [.17]	0.113 [.03]	0.078 [.02]
2900 [1368]	1.00	1.00	1.00	0.08 [.02]	0.39 [0.10]	0.91 [.23]	0.74 [.18]	0.117 [.03]	0.085 [.02]
3000 [1416]	1.01	1.01	1.00	0.08 [.02]	0.43 [0.11]	0.96 [.24]	0.79 [.20]	0.122 [.03]	0.093 [.02]
3100 [1463]	1.01	1.03	1.00	0.09 [.02]	0.47 [0.12]	1.02 [.25]	0.86 [.21]	0.127 [.03]	0.100 [.02]
3200 [1510]	1.02	1.04	1.01	0.10 [.02]	0.51 [0.13]	1.08 [.27]	0.92 [.23]	0.132 [.03]	0.108 [.03]
3300 [1557]	1.02	1.06	1.01	0.10 [.03]	0.54 [0.14]	1.15 [.29]	0.99 [.25]	0.137 [.03]	0.115 [.03]
3400 [1604]	1.03	1.08	1.01	0.11 [.03]	0.58 [0.14]	1.21 [.30]	1.05 [.26]	0.142 [.03]	0.123 [.03]
3500 [1652]	1.04	1.09	1.01	0.11 [.03]	0.62 [0.15]	1.29 [.32]	1.09 [.27]	0.147 [.04]	0.131 [.03]
3600 [1699]	1.04	1.11	1.02	0.12 [.03]	0.66 [0.16]	1.36 [.34]	1.13 [.28]	0.152 [.04]	0.138 [.03]
3700 [1746]	1.05	1.12	1.02	0.13 [.03]	0.70 [0.17]	1.43 [.36]	1.18 [.29]	0.157 [.04]	0.146 [.04]
3800 [1793]	1.05	1.14	1.02	0.13 [.03]	0.74 [0.18]	1.50 [.37]	1.23 [.31]	0.162 [.04]	0.153 [.04]
3900 [1840]	1.06	1.16	1.02	0.14 [.04]	0.77 [0.19]	1.59 [.40]	1.31 [.33]	0.167 [.04]	0.161 [.04]
4000 [1888]	1.07	1.17	1.02	0.15 [.04]	0.81 [0.20]	1.68 [.42]	1.38 [.34]	0.171 [.04]	0.169 [.04]
4100 [1935]	1.07	1.19	1.03	0.15 [.04]	0.85 [0.21]	1.74 [.43]	1.44 [.36]	0.176 [.04]	0.176 [.04]

*Multiply correction factor times gross performance data resulting sensible capacity cannot exceed total capacity.

[] Designates Metric Conversions

AIRFLOW PERFORMANCE—10 TON [35.1 kW] — 60 Hz — DOWNFLOW (CONTINUED)

Airflow CFM [L/s]	AIRFLOW CORRECTION FACTORS*			COMPONENT AIRFLOW RESISTANCE					Pressure Drop MERV 13	
	Total kBtu/h	Sensible kBtu/h	Power kW	Wet Coil	Horizontal Economizer RA Damper Open	Concentric Diffuser RXRN-AEF3415 & Concentric Adapter RXMC-DD02 (Flush)		Concentric Diffuser RXRN-AED3415 & Concentric Adapter RXMC-DD02 (Drop)		
						Resistance — Inches of Water [kPa]				
3200 [1510]	0.96	0.91	0.98	0.07 [02]	0.07 [02]	0.74 [18]	0.56 [14]	0.100 [02]	0.058 [02]	
3300 [1557]	0.97	0.92	0.99	0.07 [02]	0.08 [02]	0.79 [20]	0.59 [15]	0.104 [03]	0.065 [02]	
3400 [1604]	0.97	0.93	0.99	0.07 [02]	0.09 [02]	0.84 [21]	0.62 [15]	0.108 [03]	0.071 [02]	
3500 [1652]	0.98	0.94	0.99	0.08 [02]	0.10 [02]	0.90 [22]	0.66 [16]	0.112 [03]	0.077 [02]	
3600 [1699]	0.98	0.95	0.99	0.08 [02]	0.11 [03]	0.95 [24]	0.69 [17]	0.116 [03]	0.083 [02]	
3700 [1746]	0.99	0.97	1.00	0.09 [02]	0.12 [03]	1.00 [25]	0.73 [18]	0.120 [03]	0.089 [02]	
3800 [1793]	0.99	0.98	1.00	0.09 [02]	0.13 [03]	1.04 [26]	0.76 [19]	0.124 [03]	0.095 [02]	
3900 [1840]	1.00	0.99	1.00	0.09 [02]	0.15 [04]	1.09 [27]	0.80 [20]	0.128 [03]	0.102 [02]	
4000 [1888]	1.00	1.00	1.01	0.10 [02]	0.16 [04]	1.13 [28]	0.84 [21]	0.132 [03]	0.108 [03]	
4100 [1935]	1.00	1.01	1.01	0.10 [03]	0.17 [04]	1.19 [30]	0.88 [22]	0.136 [03]	0.114 [03]	
4200 [1982]	1.01	1.02	1.01	0.11 [03]	0.19 [05]	1.24 [31]	0.92 [23]	0.140 [03]	0.120 [03]	
4300 [2029]	1.01	1.03	1.01	0.11 [03]	0.20 [05]	1.31 [33]	0.97 [24]	0.144 [03]	0.126 [03]	
4400 [2076]	1.02	1.05	1.02	0.12 [03]	0.21 [05]	1.37 [34]	1.02 [25]	0.148 [04]	0.132 [03]	
4500 [2123]	1.02	1.06	1.02	0.13 [03]	0.23 [06]	1.43 [35]	1.07 [27]	0.152 [04]	0.138 [03]	
4600 [2171]	1.03	1.07	1.02	0.13 [03]	0.24 [06]	1.48 [37]	1.11 [28]	0.156 [04]	0.145 [04]	
4700 [2218]	1.03	1.08	1.03	0.14 [03]	0.26 [06]	1.54 [38]	1.15 [29]	0.160 [04]	0.151 [04]	
4800 [2265]	1.04	1.09	1.03	0.14 [04]	0.28 [07]	1.59 [40]	1.19 [30]	0.164 [04]	0.157 [04]	

*Multiply correction factor times gross performance data resulting sensible capacity cannot exceed total capacity.

[] Designates Metric Conversions

AIRFLOW PERFORMANCE—10 TON [35.1 kW] — 60 HZ — SIDEFLOW (CONTINUED)

Airflow	AIRFLOW CORRECTION FACTORS *			COMPONENT AIRFLOW RESISTANCE						Pressure Drop MERV 13
	CFM [L/s]	Total kBtu/h	Sensible kBtu/h	Power kW	Wet Coil	Horizontal Economizer RA Damper Open	Resistance — Inches of Water [kPa]		Pressure Drop MERV 8	
							Concentric Diffuser RXRN-AEF2000 & Concentric Adapter RXMC-DD01 (Flush)	Concentric Diffuser RXRN-AED2000 & Concentric Adapter RXMC-DD01 (Drop)		
3200 [1510]	0.96	0.91	0.99	0.98	0.07 [0.02]	0.31 [0.08]	0.74 [0.18]	0.56 [0.14]	0.100 [0.02]	0.058 [0.02]
3300 [1557]	0.97	0.92	0.99	0.99	0.07 [0.02]	0.36 [0.09]	0.79 [0.20]	0.59 [0.15]	0.104 [0.03]	0.065 [0.02]
3400 [1604]	0.97	0.93	0.99	0.99	0.07 [0.02]	0.42 [0.10]	0.84 [0.21]	0.62 [0.15]	0.108 [0.03]	0.071 [0.02]
3500 [1652]	0.98	0.94	0.99	0.99	0.08 [0.02]	0.47 [0.12]	0.90 [0.22]	0.66 [0.16]	0.112 [0.03]	0.077 [0.02]
3600 [1699]	0.98	0.95	0.99	0.99	0.08 [0.02]	0.52 [0.13]	0.95 [0.24]	0.69 [0.17]	0.116 [0.03]	0.083 [0.02]
3700 [1746]	0.99	0.97	1.00	1.00	0.09 [0.02]	0.58 [0.14]	1.00 [0.25]	0.73 [0.18]	0.120 [0.03]	0.089 [0.02]
3800 [1793]	0.99	0.98	1.00	1.00	0.09 [0.02]	0.63 [0.16]	1.04 [0.26]	0.76 [0.19]	0.124 [0.03]	0.095 [0.02]
3900 [1840]	1.00	0.99	1.00	1.00	0.09 [0.02]	0.68 [0.17]	1.09 [0.27]	0.80 [0.20]	0.128 [0.03]	0.102 [0.02]
4000 [1888]	1.00	1.00	1.01	1.01	0.10 [0.02]	0.73 [0.18]	1.13 [0.28]	0.84 [0.21]	0.132 [0.03]	0.108 [0.03]
4100 [1935]	1.00	1.01	1.01	1.01	0.10 [0.03]	0.78 [0.19]	1.19 [0.30]	0.88 [0.22]	0.136 [0.03]	0.114 [0.03]
4200 [1982]	1.01	1.02	1.01	1.01	0.11 [0.03]	0.83 [0.21]	1.24 [0.31]	0.92 [0.23]	0.140 [0.03]	0.120 [0.03]
4300 [2029]	1.01	1.03	1.01	1.01	0.11 [0.03]	0.88 [0.22]	1.31 [0.33]	0.97 [0.24]	0.144 [0.03]	0.126 [0.03]
4400 [2076]	1.02	1.05	1.02	1.02	0.12 [0.03]	0.93 [0.23]	1.37 [0.34]	1.02 [0.25]	0.148 [0.04]	0.132 [0.03]
4500 [2123]	1.02	1.06	1.02	1.02	0.13 [0.03]	0.98 [0.24]	1.43 [0.35]	1.07 [0.27]	0.152 [0.04]	0.138 [0.03]
4600 [2171]	1.03	1.07	1.02	1.02	0.13 [0.03]	1.03 [0.26]	1.48 [0.37]	1.11 [0.28]	0.156 [0.04]	0.145 [0.04]
4700 [2218]	1.03	1.08	1.03	1.03	0.14 [0.03]	1.07 [0.27]	1.54 [0.38]	1.15 [0.29]	0.160 [0.04]	0.151 [0.04]
4800 [2265]	1.04	1.09	1.03	1.03	0.14 [0.04]	1.12 [0.28]	1.59 [0.40]	1.19 [0.30]	0.164 [0.04]	0.157 [0.04]

*Multiply correction factor times gross performance data resulting sensible capacity cannot exceed total capacity.

[] Designates Metric Conversions

ELECTRICAL DATA – RHPDYB SERIES

		090ACF	090ACG 090ACH	090ADF	090ADG 090ADH
Unit Information	Unit Operating Voltage Range	187-253	187-253	414-506	414-506
	Volts	208/230	208/230	460	460
	Phase	3	3	3	3
	Hz	60	60	60	60
	Minimum Circuit Ampacity	43/43	46/46	20	21
	Minimum Circuit Ampacity with Power Exhaust	48/48	51/51	22	24
	Minimum Overcurrent Protection Device Size	50/50	60/60	25	25
	Minimum Overcurrent Protection Device Size with Power Exhaust	60/60	60/60	25	30
	Maximum Overcurrent Protection Device Size with Power Exhaust	60/60	70/70	25	30
Compressor Motor	No.	1	1	1	1
	Volts	208/230	208/230	460	460
	Phase	3	3	3	3
	Amps (RLA), Comp. 1	25.2	25.2	10.6	10.6
	Amps (LRA), Comp. 1	178.5	178.5	79.1	79.1
Condenser Motor	No.	2	2	2	2
	Volts	208/230	208/230	460	460
	Phase	1	1	1	1
	HP	1/2	1/2	1/2	1/2
	Amps (FLA, each)	2.4	2.4	1.5	1.5
	Amps (LRA, each)	5.6	5.6	3.1	3.1
Evaporator Fan	No.	1	1	1	1
	Volts	208/230	208/230	460	460
	Phase	3	3	3	3
	HP	2	3	2	3
	Amps (FLA, each)	6.2	9.2	3.0	4.6
	Amps (LRA, each)	47.0	74.5	24.0	38.1

ELECTRICAL DATA – RHPDYB SERIES					
		102ACF	102ACG 102ACH	102ADF	102ADG 102ADH
Unit Information	Unit Operating Voltage Range	187-253	187-253	414-506	414-506
	Volts	208/230	208/230	460	460
	Phase	3	3	3	3
	Hz	60	60	60	60
	Minimum Circuit Ampacity	45/45	48/48	22	24
	Minimum Circuit Ampacity with Power Exhaust	50/50	53/53	25	26
	Minimum Overcurrent Protection Device Size	60/60	60/60	25	30
	Minimum Overcurrent Protection Device Size with Power Exhaust	60/60	60/60	30	30
	Maximum Overcurrent Protection Device Size	70/70	70/70	30	35
Maximum Overcurrent Protection Device Size with Power Exhaust	70/70	70/70	35	35	
Compressor Motor	No.	1	1	1	1
	Volts	208/230	208/230	460	460
	Phase	3	3	3	3
	Amps (RLA), Comp. 1	26.8	26.8	12.5	12.5
	Amps (LRA), Comp. 1	190.7	190.7	100.2	100.2
Condenser Motor	No.	2	2	2	2
	Volts	208/230	208/230	460	460
	Phase	1	1	1	1
	HP	1/2	1/2	1/2	1/2
	Amps (FLA, each)	2.4	2.4	1.5	1.5
	Amps (LRA, each)	5.6	5.6	3.1	3.1
Evaporator Fan	No.	1	1	1	1
	Volts	208/230	208/230	460	460
	Phase	3	3	3	3
	HP	2	3	2	3
	Amps (FLA, each)	6.2	9.2	3.0	4.6
	Amps (LRA, each)	47.0	74.5	24.0	38.1

ELECTRICAL DATA – RHPDYB SERIES

		120ACF	120ACG 120ACH	120ADF	120ADG 120ADH
Unit Information	Unit Operating Voltage Range	187-253	187-253	414-506	414-506
	Volts	208/230	208/230	460	460
	Phase	3	3	3	3
	Hz	60	60	60	60
	Minimum Circuit Ampacity	45/45	48/48	24	26
	Minimum Circuit Ampacity with Power Exhaust	50/50	53/53	27	28
	Minimum Overcurrent Protection Device Size	60/60	60/60	30	30
	Minimum Overcurrent Protection Device Size with Power Exhaust	60/60	60/60	30	35
	Maximum Overcurrent Protection Device Size	70/70	70/70	35	35
Maximum Overcurrent Protection Device Size with Power Exhaust	70/70	70/70	40	40	
Compressor Motor	No.	1	1	1	1
	Volts	208/230	208/230	460	460
	Phase	3	3	3	3
	Amps (RLA), Comp. 1	26.5	26.5	14.0	14.0
	Amps (LRA), Comp. 1	255.0	255.0	123.0	123.0
Condenser Motor	No.	2	2	2	2
	Volts	208/230	208/230	460	460
	Phase	1	1	1	1
	HP	1/2	1/2	1/2	1/2
	Amps (FLA, each)	2.4	2.4	1.5	1.5
	Amps (LRA, each)	5.6	5.6	3.1	3.1
Evaporator Fan	No.	1	1	1	1
	Volts	208/230	208/230	460	460
	Phase	3	3	3	3
	HP	2	3	2	3
	Amps (FLA, each)	6.2	9.2	3.0	4.6
	Amps (LRA, each)	47.0	74.5	24.0	38.1

208/230V THREE PHASE, 60 Hz, AUXILIARY ELECTRIC HEATER KITS CHARACTERISTICS AND APPLICATION

Separate Power Supply For Both Unit and Heater Kit

Single Power Supply For Both Unit and Heater Kit

Unit Model No. RHPDYB	Heater Kit				Air Conditioner				Heater Kit				Air Conditioner						
	Model No. RXJJ-	Rated Heater kW @ 208/230V	Heater Kit FLA	Unit Min. Ckt. Ampacity	Unit Min. Ckt. Ampacity with Optional Powered Exhaust	Max. Fuse or Ckt. Bkr. Size	Max. Fuse or Ckt. Bkr. Size With Optional Powered Exhaust	Heater Kit Min. Ckt. Ampacity	Heater Kit Max Fuse or Ckt. Bkr.	Air Cond. Min. Ckt. Ampacity	Air Cond. Min. Ckt. Ampacity with Optional Powered Exhaust	Air Cond. Max Fuse or Ckt. Bkr. Size	Air Cond. Max Fuse or Ckt. Bkr. Size with Optional Powered Exhaust	Heater Kit Min. Ckt. Ampacity	Heater Kit Max Fuse or Ckt. Bkr.	Air Cond. Min. Ckt. Ampacity	Air Cond. Min. Ckt. Ampacity with Optional Powered Exhaust	Air Cond. Max Fuse or Ckt. Bkr. Size	Air Cond. Max Fuse or Ckt. Bkr. Size with Optional Powered Exhaust
090ACF	NONE*	—/—	—/—	43/43	48/48	60/60	70/70	—	—	43/43	48/48	60/60	70/70	—	—	43/43	48/48	60/60	70/70
	DD10CP	7.4/9.9	20.6/23.8	69/73	74/78	80/90	90/90	26/30	30/30	43/43	48/48	60/60	70/70	26/30	30/30	43/43	48/48	60/60	70/70
	DD15CP	10.8/14.4	30.0/34.6	80/86	86/92	90/100	100/100	38/44	40/45	43/43	48/48	60/60	70/70	38/44	40/45	43/43	48/48	60/60	70/70
	DD20CP	14.8/19.8	41.2/47.6	94/102	100/108	100/110	110/110	52/60	60/60	43/43	48/48	60/60	70/70	52/60	60/60	43/43	48/48	60/60	70/70
090ACG	DD30CP	21.6/28.8	60.0/69.3	118/130	123/135	125/150	150/150	75/87	80/90	43/43	48/48	60/60	70/70	75/87	80/90	43/43	48/48	60/60	70/70
	DD40CP	29.7/39.6	82.4/95.2	146/162	151/167	150/175	175/175	103/119	110/125	43/43	48/48	60/60	70/70	103/119	110/125	43/43	48/48	60/60	70/70
	NONE*	—/—	—/—	46/46	51/51	70/70	70/70	—	—	46/46	51/51	70/70	70/70	—	—	46/46	51/51	70/70	70/70
	DD10CP	7.4/9.9	20.6/23.8	72/76	77/81	90/90	90/90	26/30	30/30	46/46	51/51	70/70	70/70	26/30	30/30	46/46	51/51	70/70	70/70
090ACH	DD15CP	10.8/14.4	30.0/34.6	83/89	89/95	100/100	100/110	38/44	40/45	46/46	51/51	70/70	70/70	38/44	40/45	46/46	51/51	70/70	70/70
	DD20CP	14.8/19.8	41.2/47.6	97/105	103/111	110/110	110/125	52/60	60/60	46/46	51/51	70/70	70/70	52/60	60/60	46/46	51/51	70/70	70/70
	DD30CP	21.6/28.8	60.0/69.3	121/133	126/138	125/150	150/150	75/87	80/90	46/46	51/51	70/70	70/70	75/87	80/90	46/46	51/51	70/70	70/70
	DD40CP	29.7/39.6	82.4/95.2	149/165	154/170	150/175	175/175	103/119	110/125	46/46	51/51	70/70	70/70	103/119	110/125	46/46	51/51	70/70	70/70
090ACH	NONE*	—/—	—/—	46/46	51/51	70/70	70/70	—	—	46/46	51/51	70/70	70/70	—	—	46/46	51/51	70/70	70/70
	DD10CP	7.4/9.9	20.6/23.8	72/76	77/81	90/90	90/90	26/30	30/30	46/46	51/51	70/70	70/70	26/30	30/30	46/46	51/51	70/70	70/70
	DD15CP	10.8/14.4	30.0/34.6	83/89	89/95	100/100	100/110	38/44	40/45	46/46	51/51	70/70	70/70	38/44	40/45	46/46	51/51	70/70	70/70
	DD20CP	14.8/19.8	41.2/47.6	97/105	103/111	110/110	110/125	52/60	60/60	46/46	51/51	70/70	70/70	52/60	60/60	46/46	51/51	70/70	70/70
090ACH	DD30CP	21.6/28.8	60.0/69.3	121/133	126/138	125/150	150/150	75/87	80/90	46/46	51/51	70/70	70/70	75/87	80/90	46/46	51/51	70/70	70/70
	DD40CP	29.7/39.6	82.4/95.2	149/165	154/170	150/175	175/175	103/119	110/125	46/46	51/51	70/70	70/70	103/119	110/125	46/46	51/51	70/70	70/70

*= For Canadian use only. Uses "p" fuses for inductive circuit.

208/230V THREE PHASE, 60 Hz, AUXILIARY ELECTRIC HEATER KITS CHARACTERISTICS AND APPLICATION

Single Power Supply For Both Unit and Heater Kit

Unit Model No. RHPDYB	Heater Kit				Air Conditioner				Separate Power Supply For Both Unit and Heater Kit				
	Model No. RXJJ-	Rated Heater kW @ 208/230V	Heater Kit FLA	Unit Min. Ckt. Ampacity	Unit Min. Ckt. Ampacity with Optional Powered Exhaust	Max. Fuse or Ckt. Bkr. Size	Max. Fuse or Ckt. Bkr. Size With Optional Powered Exhaust	Heater Kit Min. Ckt. Ampacity	Heater Kit Max Fuse or Ckt. Bkr.	Air Cond. Min. Ckt. Ampacity	Air Cond. Min. Ckt. Ampacity with Optional Powered Exhaust	Air Cond. Max Fuse or Ckt. Bkr. Size	Air Cond. Max Ckt. Ampacity with Optional Powered Exhaust
102ACF	NONE*	—/—	—/—	45/45	50/50	70/70	70/70	—	—	45/45	50/50	70/70	70/70
	DD10CP	7.4/9.9	20.6/23.8	71/75	76/80	90/90	90/100	26/30	30/30	45/45	50/50	70/70	70/70
	DD15CP	10.8/14.4	30.0/34.6	82/88	88/94	100/100	100/110	38/44	40/45	45/45	50/50	70/70	70/70
	DD20CP	14.8/19.8	41.2/47.6	96/104	102/110	110/110	110/110	52/60	60/60	45/45	50/50	70/70	70/70
	DD30CP	21.6/28.8	60.0/69.3	120/132	125/137	125/150	125/150	75/87	80/90	45/45	50/50	70/70	70/70
102ACG	DD40CP	29.7/39.6	82.4/95.2	148/164	153/169	150/175	175/175	103/119	110/125	45/45	50/50	70/70	70/70
	NONE*	—/—	—/—	48/48	53/53	70/70	70/70	—	—	48/48	53/53	70/70	70/70
	DD10CP	7.4/9.9	20.6/23.8	74/78	79/83	90/90	100/100	26/30	30/30	48/48	53/53	70/70	70/70
	DD15CP	10.8/14.4	30.0/34.6	85/91	91/97	100/100	100/110	38/44	40/45	48/48	53/53	70/70	70/70
	DD20CP	14.8/19.8	41.2/47.6	99/107	105/113	110/110	110/125	52/60	60/60	48/48	53/53	70/70	70/70
102ACH	DD30CP	21.6/28.8	60.0/69.3	123/135	128/140	125/150	150/150	75/87	80/90	48/48	53/53	70/70	70/70
	DD40CP	29.7/39.6	82.4/95.2	151/167	156/172	175/175	175/175	103/119	110/125	48/48	53/53	70/70	70/70
	NONE*	—/—	—/—	48/48	53/53	70/70	70/70	—	—	48/48	53/53	70/70	70/70
	DD10CP	7.4/9.9	20.6/23.8	74/78	79/83	90/90	100/100	26/30	30/30	48/48	53/53	70/70	70/70
	DD15CP	10.8/14.4	30.0/34.6	85/91	91/97	100/100	100/110	38/44	40/45	48/48	53/53	70/70	70/70
102ACH	DD20CP	14.8/19.8	41.2/47.6	99/107	105/113	110/110	110/125	52/60	60/60	48/48	53/53	70/70	70/70
	DD30CP	21.6/28.8	60.0/69.3	123/135	128/140	125/150	150/150	75/87	80/90	48/48	53/53	70/70	70/70
	DD40CP	29.7/39.6	82.4/95.2	151/167	156/172	175/175	175/175	103/119	110/125	48/48	53/53	70/70	70/70

*= For Canadian use only. Uses "p" fuses for inductive circuit.

208/230V THREE PHASE, 60 Hz, AUXILIARY ELECTRIC HEATER KITS CHARACTERISTICS AND APPLICATION

Single Power Supply For Both Unit and Heater Kit

Separate Power Supply For Both Unit and Heater Kit

Unit Model No. RHPDYB	Heater Kit				Air Conditioner				Heater Kit				Air Conditioner						
	Model No. RXJJ-	Rated Heater kW @ 208/230V	Heater Kit FLA	Unit Min. Ckt. Ampacity	Unit Min. Ckt. Ampacity with Optional Powered Exhaust	Max. Fuse or Ckt. Bkr. Size	Max. Fuse or Ckt. Bkr. Size With Optional Powered Exhaust	Heater Kit Min. Ckt. Ampacity	Heater Kit Max Fuse or Ckt. Bkr.	Air Cond. Min. Ckt. Ampacity	Air Cond. Min. Ckt. Ampacity with Optional Powered Exhaust	Air Cond. Max Fuse or Ckt. Bkr. Size	Air Cond. Max Fuse or Ckt. Bkr. Size with Optional Powered Exhaust	Heater Kit Min. Ckt. Ampacity	Heater Kit Max Fuse or Ckt. Bkr.	Air Cond. Min. Ckt. Ampacity	Air Cond. Min. Ckt. Ampacity with Optional Powered Exhaust	Air Cond. Max Fuse or Ckt. Bkr. Size	Air Cond. Max Fuse or Ckt. Bkr. Size with Optional Powered Exhaust
120ACF	NONE*	—/—	—/—	45/45	50/50	70/70	70/70	—	—	45/45	50/50	70/70	70/70	—	—	45/45	50/50	70/70	70/70
	DD10CP	7.4/9.9	20.6/23.8	70/74	76/80	90/90	90/90	26/30	30/30	45/45	50/50	70/70	70/70	26/30	30/30	45/45	50/50	70/70	70/70
	DD15CP	10.8/14.4	30.0/34.6	82/88	88/93	100/100	100/100	38/44	40/45	45/45	50/50	70/70	70/70	38/44	40/45	45/45	50/50	70/70	70/70
	DD20CP	14.8/19.8	41.2/47.6	96/104	102/110	110/110	110/110	52/60	60/60	45/45	50/50	70/70	70/70	52/60	60/60	45/45	50/50	70/70	70/70
120ACG	DD30CP	21.6/28.8	60.0/69.3	120/131	125/137	125/150	125/150	75/87	80/90	45/45	50/50	70/70	70/70	75/87	80/90	45/45	50/50	70/70	70/70
	DD40CP	29.7/39.6	82.4/95.2	148/164	153/169	150/175	150/175	103/119	110/125	45/45	50/50	70/70	70/70	103/119	110/125	45/45	50/50	70/70	70/70
	NONE*	—/—	—/—	48/48	53/53	70/70	70/70	—	—	48/48	53/53	70/70	70/70	—	—	48/48	53/53	70/70	70/70
	DD10CP	7.4/9.9	20.6/23.8	73/77	79/83	90/90	90/100	26/30	30/30	48/48	53/53	70/70	70/70	26/30	30/30	48/48	53/53	70/70	70/70
120ACH	DD15CP	10.8/14.4	30.0/34.6	85/91	91/96	100/100	100/100	38/44	40/45	48/48	53/53	70/70	70/70	38/44	40/45	48/48	53/53	70/70	70/70
	DD20CP	14.8/19.8	41.2/47.6	99/107	105/113	110/110	110/125	52/60	60/60	48/48	53/53	70/70	70/70	52/60	60/60	48/48	53/53	70/70	70/70
	DD30CP	21.6/28.8	60.0/69.3	123/134	128/140	125/150	150/150	75/87	80/90	48/48	53/53	70/70	70/70	75/87	80/90	48/48	53/53	70/70	70/70
	DD40CP	29.7/39.6	82.4/95.2	151/167	156/172	175/175	175/175	103/119	110/125	48/48	53/53	70/70	70/70	103/119	110/125	48/48	53/53	70/70	70/70
120ACH	NONE*	—/—	—/—	48/48	53/53	70/70	70/70	—	—	48/48	53/53	70/70	70/70	—	—	48/48	53/53	70/70	70/70
	DD10CP	7.4/9.9	20.6/23.8	73/77	79/83	90/90	90/100	26/30	30/30	48/48	53/53	70/70	70/70	26/30	30/30	48/48	53/53	70/70	70/70
	DD15CP	10.8/14.4	30.0/34.6	85/91	91/96	100/100	100/110	38/44	40/45	48/48	53/53	70/70	70/70	38/44	40/45	48/48	53/53	70/70	70/70
	DD20CP	14.8/19.8	41.2/47.6	99/107	105/113	110/110	110/125	52/60	60/60	48/48	53/53	70/70	70/70	52/60	60/60	48/48	53/53	70/70	70/70
120ACH	DD30CP	21.6/28.8	60.0/69.3	123/134	128/140	125/150	150/150	75/87	80/90	48/48	53/53	70/70	70/70	75/87	80/90	48/48	53/53	70/70	70/70
	DD40CP	29.7/39.6	82.4/95.2	151/167	156/172	175/175	175/175	103/119	110/125	48/48	53/53	70/70	70/70	103/119	110/125	48/48	53/53	70/70	70/70

*= For Canadian use only. Uses "ipr" fuses for inductive circuit.

460V THREE PHASE, 60 Hz, AUXILIARY ELECTRIC HEATER KITS CHARACTERISTICS AND APPLICATION

Separate Power Supply For Both Unit and Heater Kit

Unit Model Number RHPDYB	Heater Kit				Air Conditioner				Heater Kit				Air Conditioner			
	Model No. RXJJ-	Rated Heater kW @ 460	Heater Kit FLA	Heater Kit	Unit Min. Ckt. Ampacity	Unit Min. Ckt. Ampacity with Optional Powered Exhaust	Max. Fuse or Ckt. Bkr. Size	Max. Fuse or Ckt. Bkr. Size With Optional Powered Exhaust	Heater Kit Min. Ckt. Ampacity	Heater Kit Max Fuse or Ckt. Bkr. Size	Air Cond. Min. Ckt. Ampacity with Optional Powered Exhaust	Air Cond. Min. Ckt. Ampacity with Optional Powered Exhaust	Air Cond. Max Fuse or Ckt. Bkr. Size	Air Cond. Max Fuse or Ckt. Bkr. Size with Optional Powered Exhaust		
090ADF	NONE*	—	—	—	20	22	25	30	—	—	20	22	25	30		
	DD10DNV	9.9	11.9	11.9	35	37	40	40	15	15	20	22	25	30		
	DD15DNV	14.4	17.3	17.3	41	44	45	45	22	25	20	22	25	30		
	DD20DNV	19.8	23.8	23.8	49	52	50	60	30	30	20	22	25	30		
	DD30DNV	28.8	34.6	34.6	63	66	70	70	44	45	20	22	25	30		
	DD40DNV	39.6	47.6	47.6	79	82	80	90	60	60	20	22	25	30		
090ADG	NONE*	—	—	—	21	24	30	30	—	—	21	24	30	30		
	DD10DNV	9.9	11.9	11.9	36	39	40	45	15	15	21	24	30	30		
	DD15DNV	14.4	17.3	17.3	43	46	45	50	22	25	21	24	30	30		
	DD20DNV	19.8	23.8	23.8	51	54	60	60	30	30	21	24	30	30		
	DD30DNV	28.8	34.6	34.6	65	67	70	70	44	45	21	24	30	30		
	DD40DNV	39.6	47.6	47.6	81	84	90	90	60	60	21	24	30	30		
090ADH	NONE*	—	—	—	21	24	30	30	—	—	21	24	30	30		
	DD10DNV	9.9	11.9	11.9	36	39	40	45	15	15	21	24	30	30		
	DD15DNV	14.4	17.3	17.3	43	46	45	50	22	25	21	24	30	30		
	DD20DNV	19.8	23.8	23.8	51	54	60	60	30	30	21	24	30	30		
	DD30DNV	28.8	34.6	34.6	65	67	70	70	44	45	21	24	30	30		
	DD40DNV	39.6	47.6	47.6	81	84	90	90	60	60	21	24	30	30		
102ADF	NONE*	—	—	—	22	25	30	35	—	—	22	25	30	35		
	DD10DNV	9.9	11.9	11.9	37	40	45	45	15	15	22	25	30	35		
	DD15DNV	14.4	17.3	17.3	44	46	50	50	22	25	22	25	30	35		
	DD20DNV	19.8	23.8	23.8	52	55	60	60	30	30	22	25	30	35		
	DD30DNV	28.8	34.6	34.6	65	68	70	70	44	45	22	25	30	35		
	DD40DNV	39.6	47.6	47.6	82	84	90	90	60	60	22	25	30	35		
102ADG	NONE*	—	—	—	24	26	35	35	—	—	24	26	35	35		
	DD10DNV	9.9	11.9	11.9	39	41	45	50	15	15	24	26	35	35		
	DD15DNV	14.4	17.3	17.3	45	48	50	50	22	25	24	26	35	35		
	DD20DNV	19.8	23.8	23.8	53	56	60	60	30	30	24	26	35	35		
	DD30DNV	28.8	34.6	34.6	67	70	70	70	44	45	24	26	35	35		
	DD40DNV	39.6	47.6	47.6	83	86	90	90	60	60	24	26	35	35		

*= For Canadian use only. Uses "rp" fuses for inductive circuit.

460V THREE PHASE, 60 Hz, AUXILIARY ELECTRIC HEATER KITS CHARACTERISTICS AND APPLICATION												
Single Power Supply For Both Unit and Heater Kit						Separate Power Supply For Both Unit and Heater Kit						
Unit Model Number RHPDYB	Heater Kit			Air Conditioner			Heater Kit			Air Conditioner		
	Model No. RXJJ-	Rated Heater kW @ 460	Heater Kit FLA	Unit Min. Ckt. Ampacity	Unit Min. Ckt. Ampacity with Optional Powered Exhaust	Max. Fuse or Ckt. Size Bkr. Size	Max. Fuse or Ckt. Size With Optional Powered Exhaust	Heater Kit Min. Ckt. Ampacity	Heater Kit Max Fuse or Ckt. Bkr. Size	Air Cond. Min. Ckt. Ampacity with Optional Powered Exhaust	Air Cond. Max Fuse or Ckt. Bkr. Size	Air Cond. Max. Fuse or Ckt. Bkr. Size with Optional Powered Exhaust
102ADH	NONE*	—	—	24	26	35	35	—	—	24	35	35
	DD10DNV	9.9	11.9	39	41	45	50	15	15	24	35	35
	DD15DNV	14.4	17.3	45	48	50	50	22	25	24	35	35
	DD20DNV	19.8	23.8	53	56	60	60	30	30	24	35	35
	DD30DNV	28.8	34.6	67	70	70	70	44	45	24	35	35
	DD40DNV	39.6	47.6	83	86	90	90	60	60	24	35	35
120ADF	NONE*	—	—	24	27	35	40	—	—	24	35	40
	DD10DNV	9.9	11.9	39	42	45	50	15	15	24	35	40
	DD15DNV	14.4	17.3	46	48	50	50	22	25	24	35	40
	DD20DNV	19.8	23.8	54	56	60	60	30	30	24	35	40
	DD30DNV	28.8	34.6	67	70	70	70	44	45	24	35	40
	DD40DNV	39.6	47.6	83	86	90	90	60	60	24	35	40
120ADG	NONE*	—	—	26	28	35	40	—	—	26	35	40
	DD10DNV	9.9	11.9	40	43	50	50	15	15	26	35	40
	DD15DNV	14.4	17.3	47	50	50	50	22	25	26	35	40
	DD20DNV	19.8	23.8	55	58	60	60	30	30	26	35	40
	DD30DNV	28.8	34.6	69	72	70	80	44	45	26	35	40
	DD40DNV	39.6	47.6	85	88	90	90	60	60	26	35	40
120ADH	NONE*	—	—	26	28	35	40	—	—	26	35	40
	DD10DNV	9.9	11.9	40	43	50	50	15	15	26	35	40
	DD15DNV	14.4	17.3	47	50	50	50	22	25	26	35	40
	DD20DNV	19.8	23.8	55	58	60	60	30	30	26	35	40
	DD30DNV	28.8	34.6	69	72	70	80	44	45	26	35	40
	DD40DNV	39.6	47.6	85	88	90	90	60	60	26	35	40

*= For Canadian use only. Uses "P" fuses for inductive circuit.

A2L REFRIGERANT INSTALLATION SAFETY DATA

Model		RHPDYB090	RHPDYB102	RHPDYB120
Refrigerant Charge Weight (oz)		172.8	211.2	209.6
Minimum Circulation Qmin (cfm)		575.0	702.0	697.0
Altitude above Sea Level (ft)	Altitude Adjustment Factor	Minimum total space area, TAmin (sq-ft)		
0	1.000	319	389	386
1000	1.025	326	399	396
2000	1.051	335	409	406
3000	1.078	343	420	416
4000	1.107	353	431	428
5000	1.138	362	443	440
6000	1.170	373	455	452
6500	1.187	378	462	459

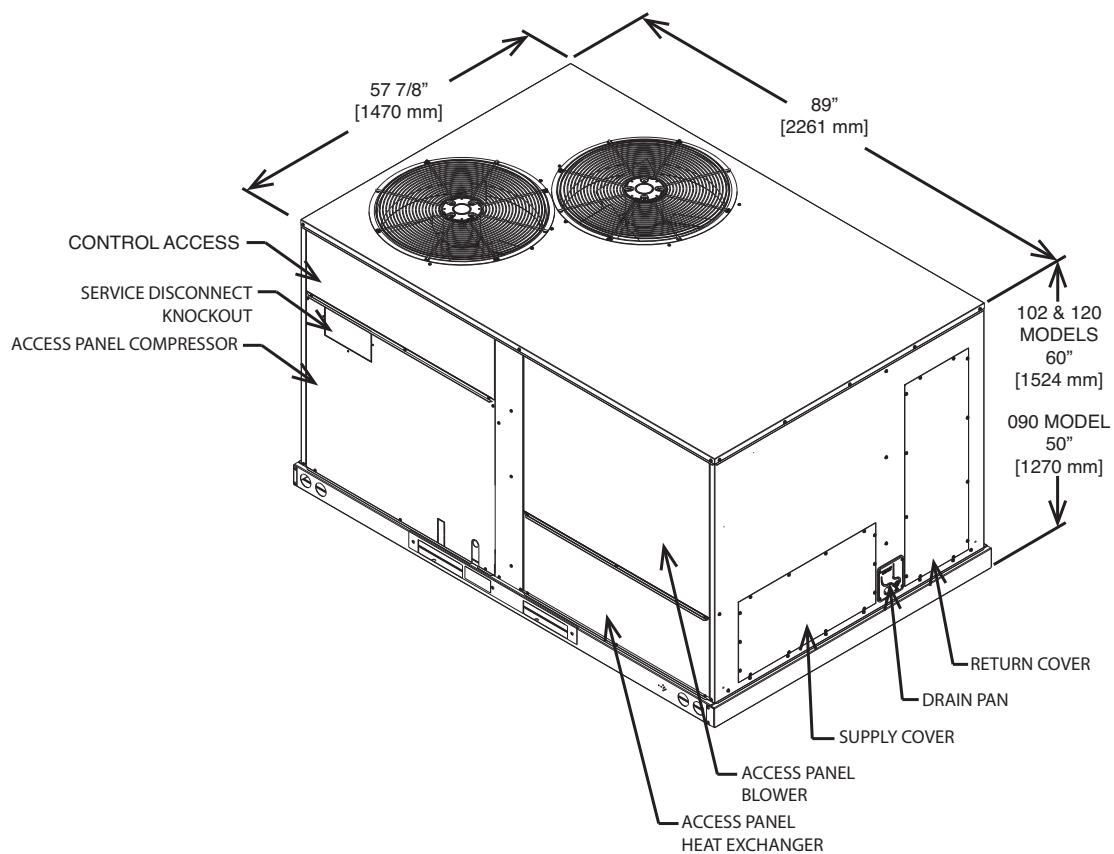

Illustration
ST-A1273-26_B-00

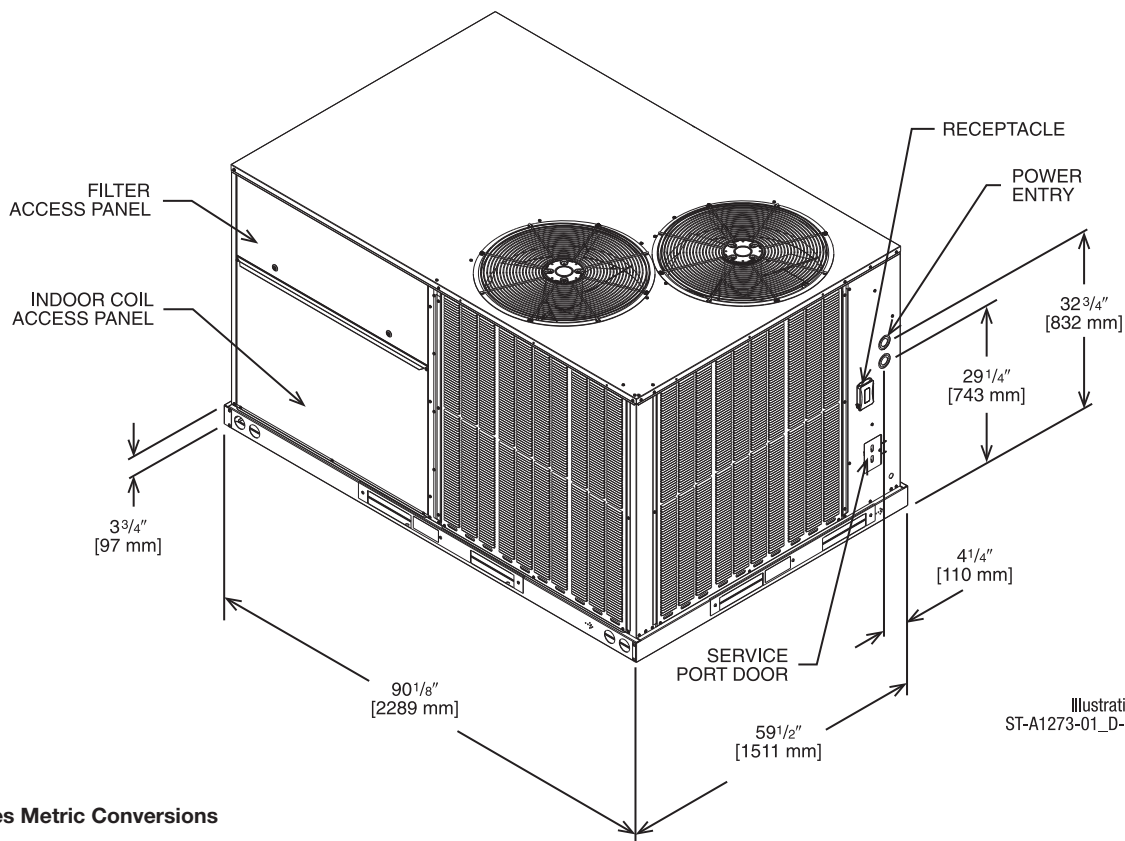
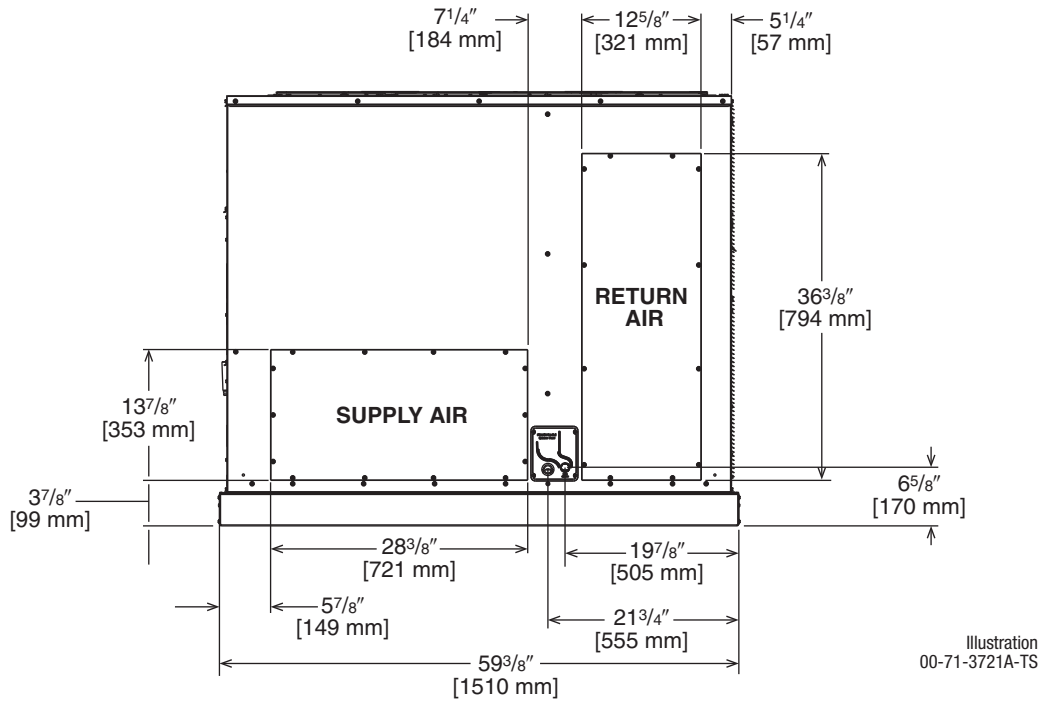

Illustration
ST-A1273-01_D-00

[] Designates Metric Conversions

SUPPLY AND RETURN DIMENSIONS FOR HORIZONTAL APPLICATIONS



**SUPPLY AND RETURN DIMENSIONS FOR DOWNFLOW APPLICATIONS
(VIEW FROM BOTTOM UP)**

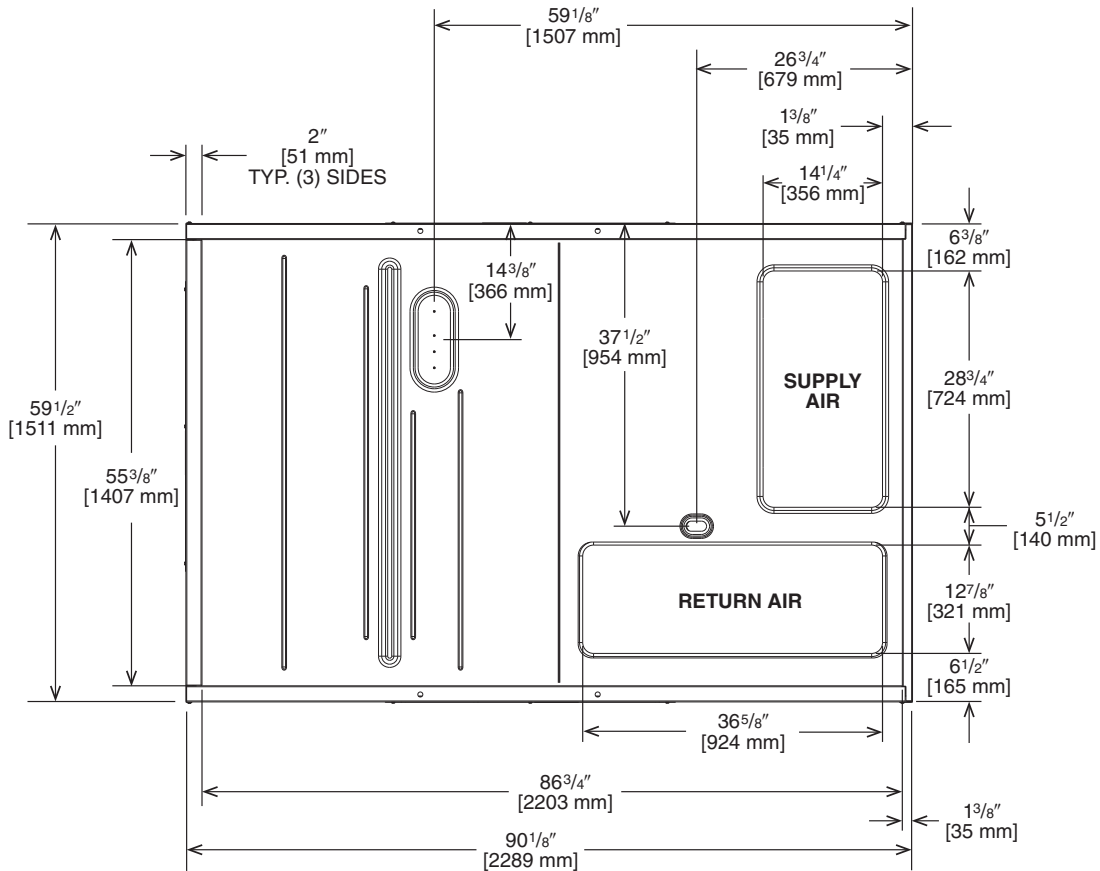

[] Designates Metric Conversions

WEIGHTS

Capacity Tons [kW]	Corner Weights by Percentage			
	A	B	C	D
7.5-10 [21.1-35.2]	26%	34%	17%	23%

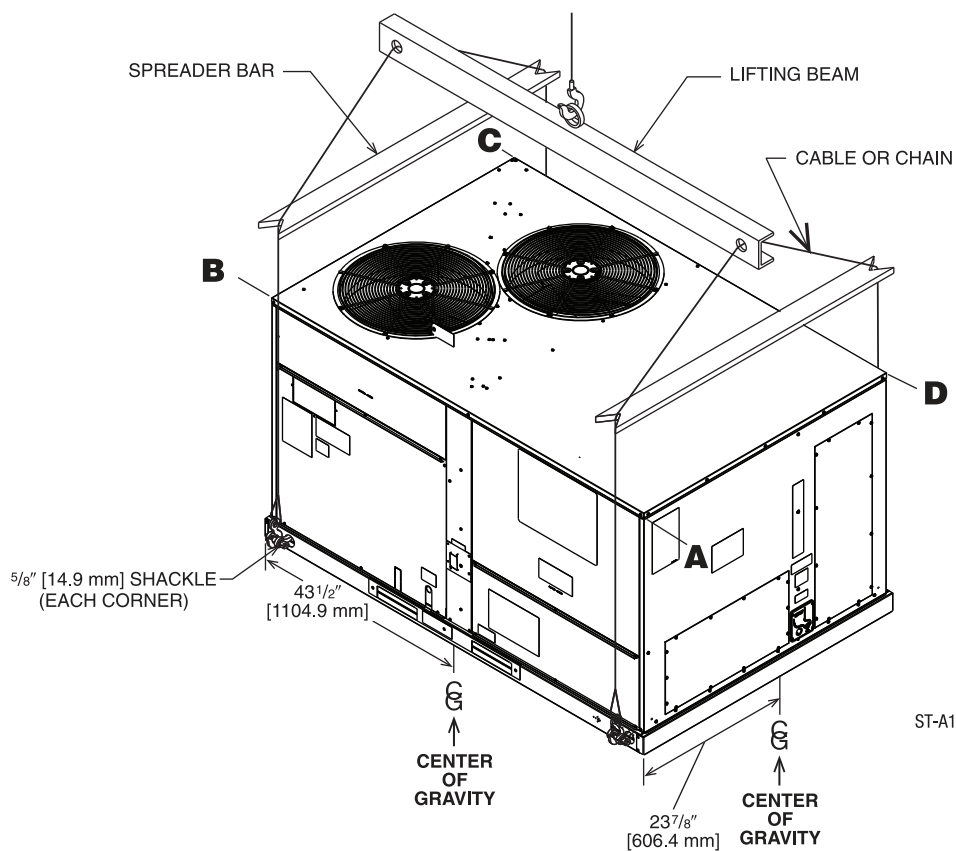

Illustration
ST-A1273-01_J-00

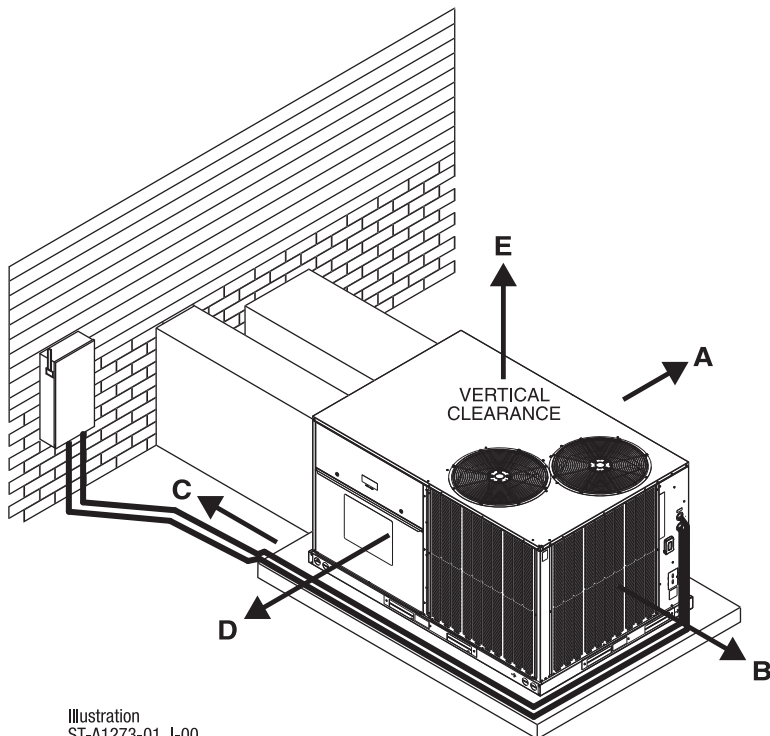

Illustration
ST-A1273-01_J-00

CLEARANCES

The following minimum clearances must be observed for proper unit performance and serviceability.

RECOMMENDED CLEARANCE In. [mm]	LOCATION
48 [1219]	A - FRONT
24 [609]	B - CONDENSER END
48 [1219] ①	C - DUCT END
24 [609] ②	D - FILTER SIDE
60 [1524]	E - ABOVE

① 18" [457 mm] MINIMUM IF DRAINPAN WILL NOT BE REMOVED.

② 48" [1219 MM] MINIMUM IF ECONOMIZER IS INSTALLED.

FIELD-INSTALLED ACCESSORY EQUIPMENT

Accessory	Model Number	Shipping Weight Lbs. [kg]	Installed Weight Lbs. [kg]	Factory Installation Available?
Economizers				
DDC Economizer with Single Enthalpy (Downflow) <i>MicroMetl Economizer with Honeywell Controller</i>	RXRD-01MDDBM3	86 [39.0]	57 [25.9]	No
DDC Economizer with Single Enthalpy (Horizontal) <i>MicroMetl Economizer with Honeywell Controller</i>	RXRD-01MDHBM3	84 [38.1]	55 [24.9]	No
Non-DDC Economizer with No Controls (Downflow) <i>MicroMetl Economizer, Belimo Actuator</i>	RXRD-31MDDAM3	86 [39.0]	57 [25.9]	No
Non-DDC Economizer with Single Enthalpy (Downflow) <i>MicroMetl Economizer with Siemens Controls</i>	RXRD-11MDDAM3	86 [39.0]	57 [25.9]	Yes
Non-DDC Economizer with Single Enthalpy (Downflow) <i>Ruskin Rooftop Systems Economizer with RRS Basic Controller</i>	RXRD-41MDDAM3	86 [39.0]	57 [25.9]	Yes
Non-DDC Economizer with Single Enthalpy (Downflow) <i>Ruskin Rooftop System Economizer with Siemens Controller</i>	RXRD-51MDDAM3	86 [39.0]	57 [25.9]	Yes
Non-DDC Economizer with Single Enthalpy (Horizontal) <i>MicroMetl Economizer with Siemens Controls</i>	RXRD-11MDHAM3	84 [38.1]	55 [24.9]	No
Non-DDC Economizer with Single Enthalpy (Horizontal) <i>Ruskin Rooftop Systems Economizer with RRS Basic Controller</i>	RXRD-41MDHAM3	84 [38.1]	55 [24.9]	No
Non-DDC Economizer with Single Enthalpy (Horizontal) <i>Ruskin Rooftop System Economizer with Siemens Controller</i>	RXRD-51MDHAM3	84 [38.1]	55 [24.9]	No
Economizer Universal DDC Interface Kit	RXRX-DDC01	5 [2.7]	3.5 [1.6]	Yes

Accessory	Model Number	Shipping Weight Lbs. [kg]	Installed Weight Lbs. [kg]	Factory Installation Available?
Comfort Alert ¹ (3 Phase) DDC	RXRX-AZ01	3 [1.5]	2 [0.9]	Yes
Comfort Alert ¹ (3 Phase) Non-DDC	RXRX-AZ02	3 [1.5]	2 [0.9]	Yes
Communication Card, BACnet	RXRX-AY01	1 [0.5]	1 [0.5]	No
Communication Card, LonWorks	RXRX-AY02	1 [0.5]	1 [0.5]	No
Concentric Adapter 7.5/8.5 Ton Drop	RXMC-DD01	40 [18.1]	34 [15.4]	No
Concentric Adapter 10 Ton Drop	RXMC-DD02	75 [34.0]	65 [29.5]	No
Concentric Diffuser 7.5/8.5 Ton Drop	RXRN-AED2000	35 [15.9]	30 [13.6]	No
Concentric Diffuser 10.0 Ton Drop	RXRN-AED3415	170 [77.1]	160 [72.6]	No
Concentric Diffuser 7.5/8.5 Ton Flush	RXRN-AEF2000	30 [13.6]	25 [11.3]	No
Concentric Diffuser 10.0 Ton Flush	RXRN-AEF3415	140 [113.4]	130 [59.0]	No
Convenience Outlet, Unfused	RXRX-BN01	2 [1.0]	1.5 [0.7]	Yes
Dual Enthalpy Kit (for Honeywell Jade™)	RXRX-BV01	1 [0.5]	1 [0.5]	No
Dual Enthalpy Kit DDC (for Honeywell DDC)	RXRX-BV02	1 [0.5]	1 [0.5]	No
Dual Enthalpy, Temperature and Humidity Sensor (for Siemens)	PD555460	1 [0.5]	1 [0.5]	No

[] Designates Metric Conversions

FIELD-INSTALLED ACCESSORY EQUIPMENT (CONTINUED)

Accessory	Model Number	Shipping Weight Lbs. [kg]	Installed Weight Lbs. [kg]	Factory Installation Available?
Electric Heater Kits	RXJJ-DD10CP	30 [13.6]	27.5 [12.5]	Yes
	RXJJ-DD15CP	32 [14.5]	29.5 [13.4]	Yes
	RXJJ-DD20CP	34 [15.4]	31.5 [14.3]	Yes
	RXJJ-DD30CP	37 [16.8]	34.5 [15.6]	Yes
	RXJJ-DD40CP	40 [18.1]	37.5 [17.0]	Yes
	RXJJ-DD10DNV	30 [13.6]	27.5 [12.5]	Yes
	RXJJ-DD15DNV	32 [14.5]	29.5 [13.4]	Yes
	RXJJ-DD20DNV	34 [15.4]	31.5 [14.3]	Yes
	RXJJ-DD30DNV	37 [16.8]	34.5 [15.6]	Yes
RXJJ-DD40DNV	40 [18.1]	37.5 [17.0]	Yes	
Freeze Stat Kit	RXR-AM01	2 [1.0]	1.5 [0.7]	Yes
Fresh Air Damper, Manual	RXRF-ADA1	15 [6.8]	12 [5.4]	No
Fresh Air Damper, Motorized	RXRF-ADB1	38 [17.2]	31 [14.06]	No
Fresh Air Damper, Motorized (DDC)	RXRF-ADC1	38 [17.2]	31 [14.06]	No
Low-Ambient Control Kit	RXRZ-A04	4 [1.8]	3 [1.4]	Yes
MERV 8 Filter 7.5/8.5 Ton	RXMF-M08A22020	2 [0.9]	1 [0.45]	No
MERV 8 Filter 10 Ton	RXMF-M08A22520	2 [0.9]	1 [0.45]	No
MERV 13 Filter 7.5/8.5 Ton	RXMF-M13A22020	2 [0.9]	1 [0.45]	No
MERV 13 Filter 10 Ton	RXMF-M13A22520	2 [0.9]	1 [0.45]	No
Power Exhaust (230V) Kit, Convertible MicroMetl	RXR-CDF01C	58 [26.3]	48 [21.8]	No
Power Exhaust (460V) Kit, Convertible MicroMetl	RXR-CDF01D	50 [22.7]	44 [20.0]	No
Power Exhaust (230V) Kit for Downflow Economizer (RRS)	RXR-RDF01C	104 [47.2]	94 [42.6]	No
Power Exhaust (460V) Kit for Downflow Economizer (RRS)	RXR-RDF01D	104 [47.2]	94 [42.6]	No
Power Exhaust (230V) Kit for Horizontal Economizer (RRS)	RXR-RDF03C	104 [47.2]	94 [42.6]	No
Power Exhaust (460V) Kit for Horizontal Economizer (RRS)	RXR-RDF03D	104 [47.2]	94 [42.6]	No
Roofcurb, 14"	RXKG-DDD14	109 [49.4]	104 [47.2]	No
Roofcurb, 14" Welded	RXKG-SD14	109 [49.4]	104 [47.2]	No
Roofcurb, 24"	RXKG-DDD24	109 [49.4]	104 [47.2]	No
Roofcurb, 24" Welded	RXKG-SD24	145 [65.8]	140 [63.5]	No
Roofcurb Adapter ²	RXR-DDCAE	235 [106.6]	215 [97.5]	No
Outdoor Coil Louver Kit - 7.5 & 8.5 Ton	RXR-ADD04A	52 [23.6]	47 [21.3]	Yes
Outdoor Coil Louver Kit - 10 ton	RXR-ADD04B	43 [19.5]	39 [17.7]	Yes
Single Point Wiring Kit	RXJX-AC0605	23 [10.4]	25 [11.3]	No
	RXJX-AC0805	24 [10.9]	26 [11.8]	No
	RXJX-AD0405	25 [11.3]	27 [12.2]	No
	RXJX-AD0605	25 [11.3]	27 [12.2]	No
	RXJX-AD0409	25 [11.3]	27 [12.2]	No
	RXJX-AC0909	26 [11.8]	28 [12.7]	No
	RXJX-AD0609	25 [11.3]	27 [12.2]	No
Sensor, Carbon Dioxide (Wall Mount)	RXR-AR02	3 [1.4]	2 [1.0]	No
Sensor, Room Humidity	RHC-ZNS4	1 [0.5]	1 [0.5]	No
Sensor, Room Temperature and Relative Humidity	RHC-ZNS5	1 [0.5]	1 [0.5]	No
Smoke Detector Kit, Return	RXR-BS03	5 [2.7]	3.5 [1.6]	No
Smoke Detector Kit, Return/Supply	RXR-BS04	7 [3.2]	5 [2.7]	No
Unfused Service Disconnect	RXR-BP01	10 [4.5]	9 [4.1]	Yes
UV-C Kit 208V/230V Ren D Cabinet	RXR-UVCTD	8 [3.6]	6 [2.7]	No
UV-C Transformer 460V/575V Ren D Cabinet	RXR-UVCTD	12 [5.4]	11 [5.0]	No

¹One (1) Comfort Alert required per compressor.

²Compatible with roofcurbs RXKG-CAE14 or RXKG-CAE24.

[] Designates Metric Conversions

COMMUNICATION CARDS

Field-Installed

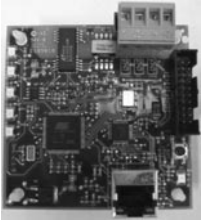

BACnet COMMUNICATION CARD RXRX-AY01

The field-installed BACnet Communication Card allows the RTU-C unit controller to communicate with a third party building management system that supports the BACnet Application Specific Controller device profile. The BACnet Communication Module plugs onto the unit RTU-C controller and allows communication between the RTU-C and the BACnet MSTP network.

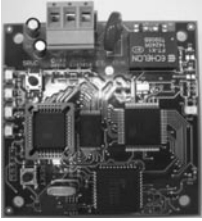

LonWorks COMMUNICATION CARD RXRX-AY02

The field-installed LonWorks Communication Card allows the RTU-C unit controller to communicate with a third party building management system that supports the LonMark Space Comfort Controller (SCC) functional profile or LonMark Discharge Air Controller (DAC) functional profile. The LonMark Communication Module plugs onto the RTU-C controller and allows communication between the RTU-C and a LonWorks Network.

CONCENTRIC DIFFUSER APPLICATION

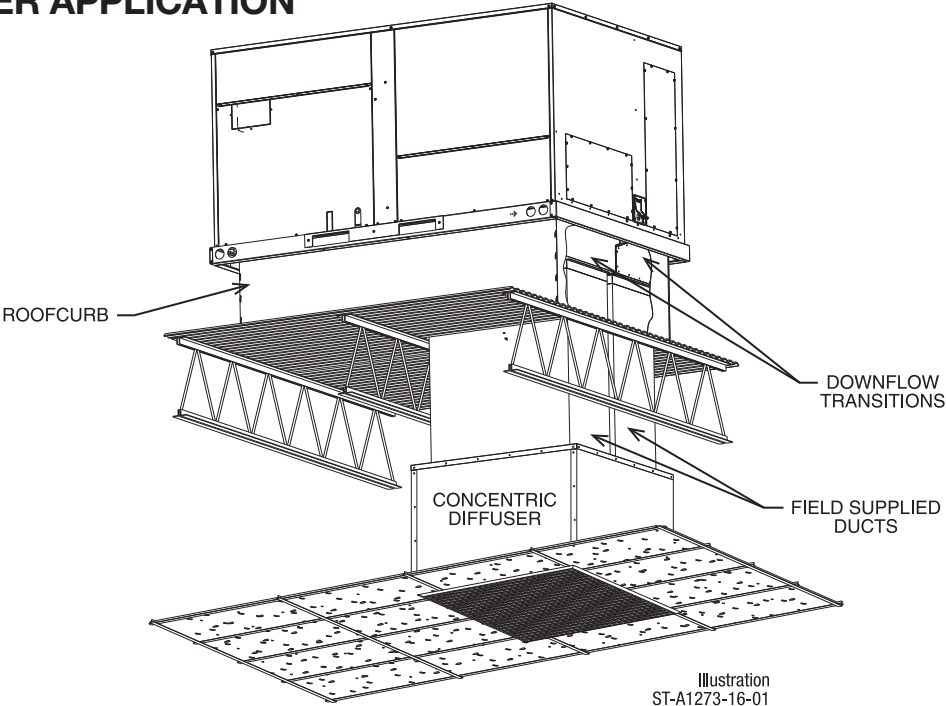

DOWNFLOW TRANSITION DRAWINGS

RXMC-DD01 – Concentric Adapter 7.5 / 8.5 Ton Drop

- Used with RXRN-AEF2000 or RXRN-AED2000 Concentric Diffusers

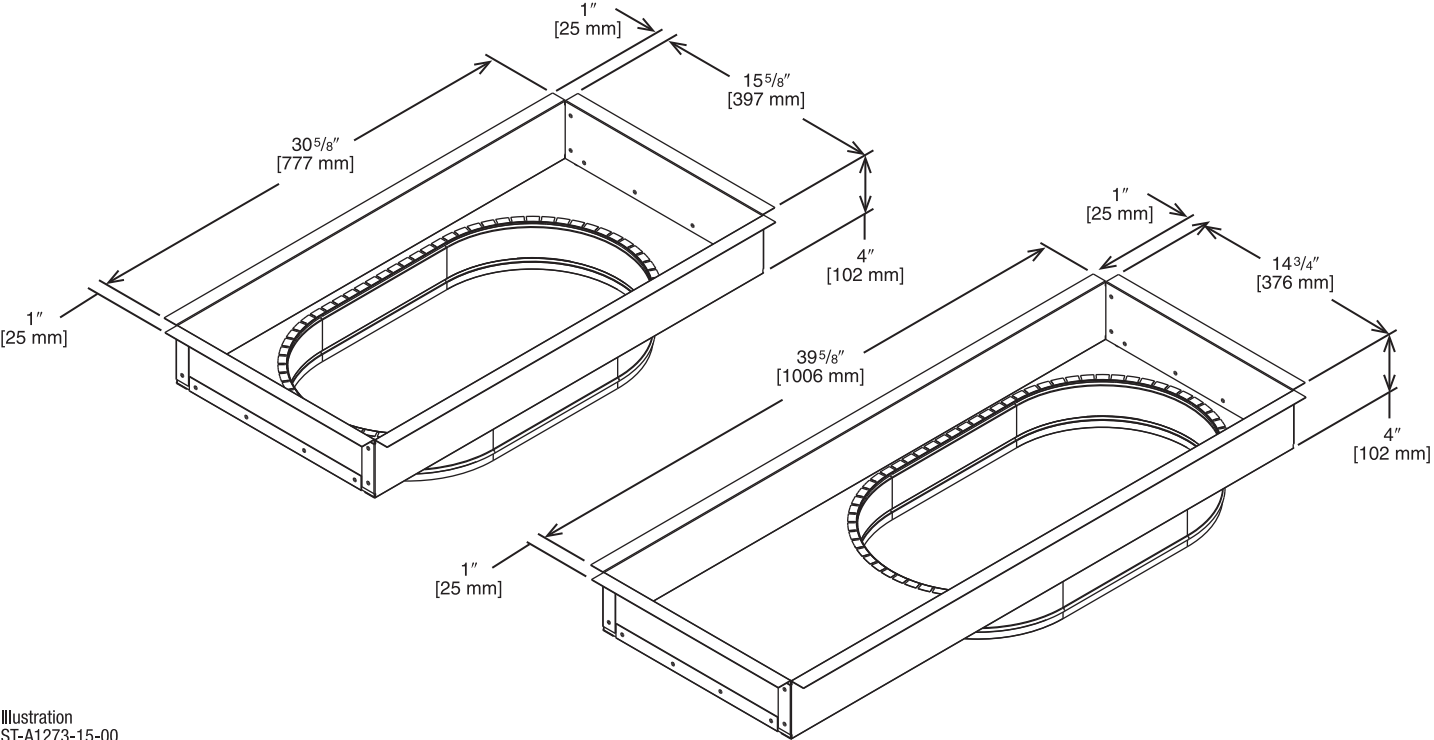

[] Designates Metric Conversions

DOWNFLOW TRANSITION DRAWINGS

RXMC-DD02—Concentric Adapter 10 Ton Drop

- Used with RXRN-AEF3415
or RXRN-AED3415
Concentric Diffusers

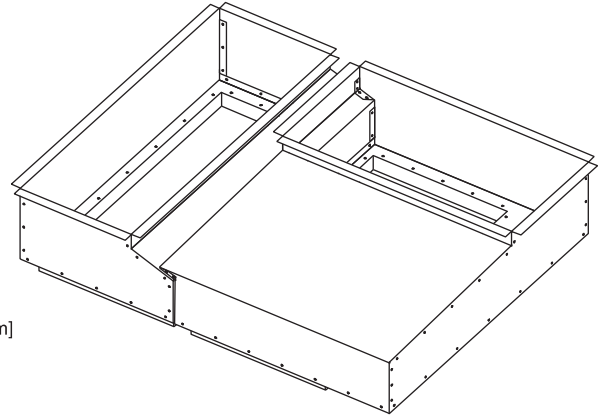
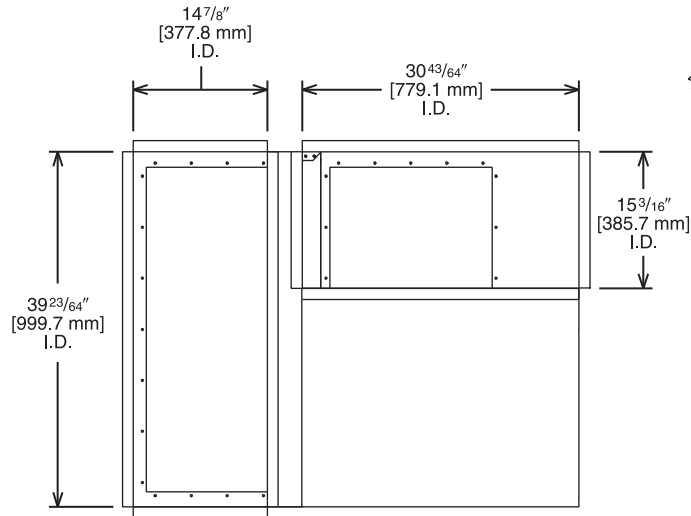
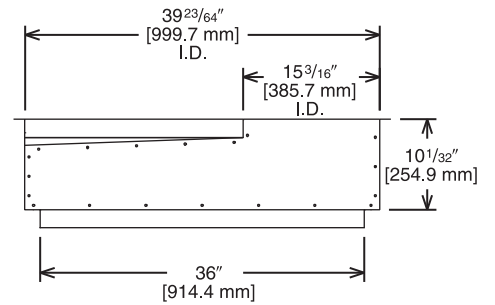
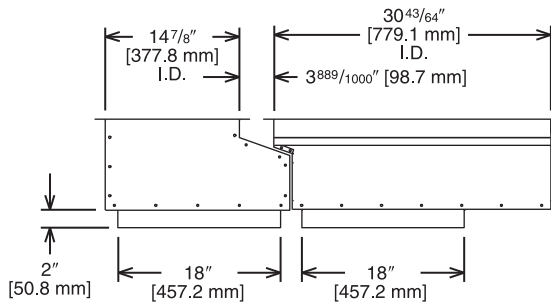

Illustration
ADS-106193-03



[] Designates Metric Conversions

CONCENTRIC DIFFUSER 7.5/8.5 TON DROP

RXRN-AED2000

For Use With Downflow Transition (RXMC-DD01)
and 20" [508 mm] Round Supply and Return Ducts

- All aluminum diffuser with aluminum return air eggcrate
- Built-in anti-sweat gasket
- Molded fiberglass supports
- Built-in hanging supports
- Diffuser box constructed of sheet metal insulated with 1" [25.4 mm] 1.5 lbs. [.7 kg] duct liner

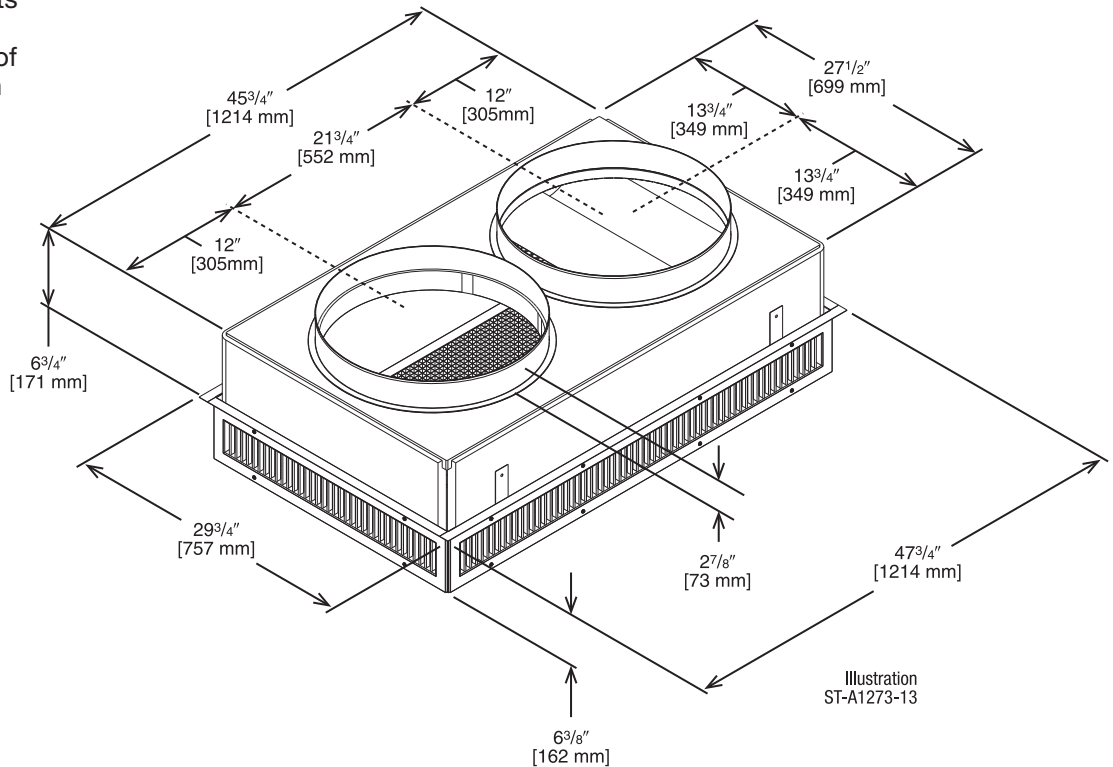

ENGINEERING DATA^①

MODEL NO.	FLOW RATE CFM [L/s]	THROW ^{② ③} FEET [m]	NECK VELOCITY FPM [m/s]	NOISE LEVEL ^④ (dba)
RXRN-AED2000	2600 [1222]	22-39 [6.7-11.9]	669 [3.4]	32
	2800 [1316]	23-40 [7.1-12.2]	720 [3.7]	38
	3000 [1410]	25-42 [7.6-12.8]	772 [3.9]	40
	3200 [1504]	26-43 [7.9-13.1]	823 [4.2]	41
	3400 [1598]	27-45 [8.2-13.7]	874 [4.4]	42
	3600 [1692]	30-50 [9.1-15.2]	925.5 [4.7]	45
	3800 [1786]	32-53 [9.8-16.2]	976.8 [4.9]	48
	4000 [1880]	34-56 [10.4-17.1]	1028.1 [5.2]	50

NOTES: ① All data is based on the air diffusion council guidelines.

② Throw data is based on 75 FPM Terminal Velocities using isothermal air.

③ Throw is based on diffuser blades being directed in a straight pattern.

④ Actual noise levels may vary due to duct design and do not include transmitted unit noise.
Adequate duct attenuation must be provided to reduce sound output from the unit.

[] Designates Metric Conversions

CONCENTRIC DIFFUSER 10.0 TON DROP 15" x 34" [381 x 836 mm]

RXRN-AED3415

For Use With Downflow Transition (RXMC-DD02)
and 15" x 34" [381 x 836 mm]
Supply and Return Ducts

- All aluminum diffuser with aluminum return air eggcrate
- Built-in anti-sweat gasket
- Molded fiberglass supports
- Built-in hanging supports
- Diffuser box constructed of sheet metal insulated with 1" [25.4 mm] 1.5 lbs. [.7 kg] duct liner
- Double deflection diffuser with the blades secured by spring steel

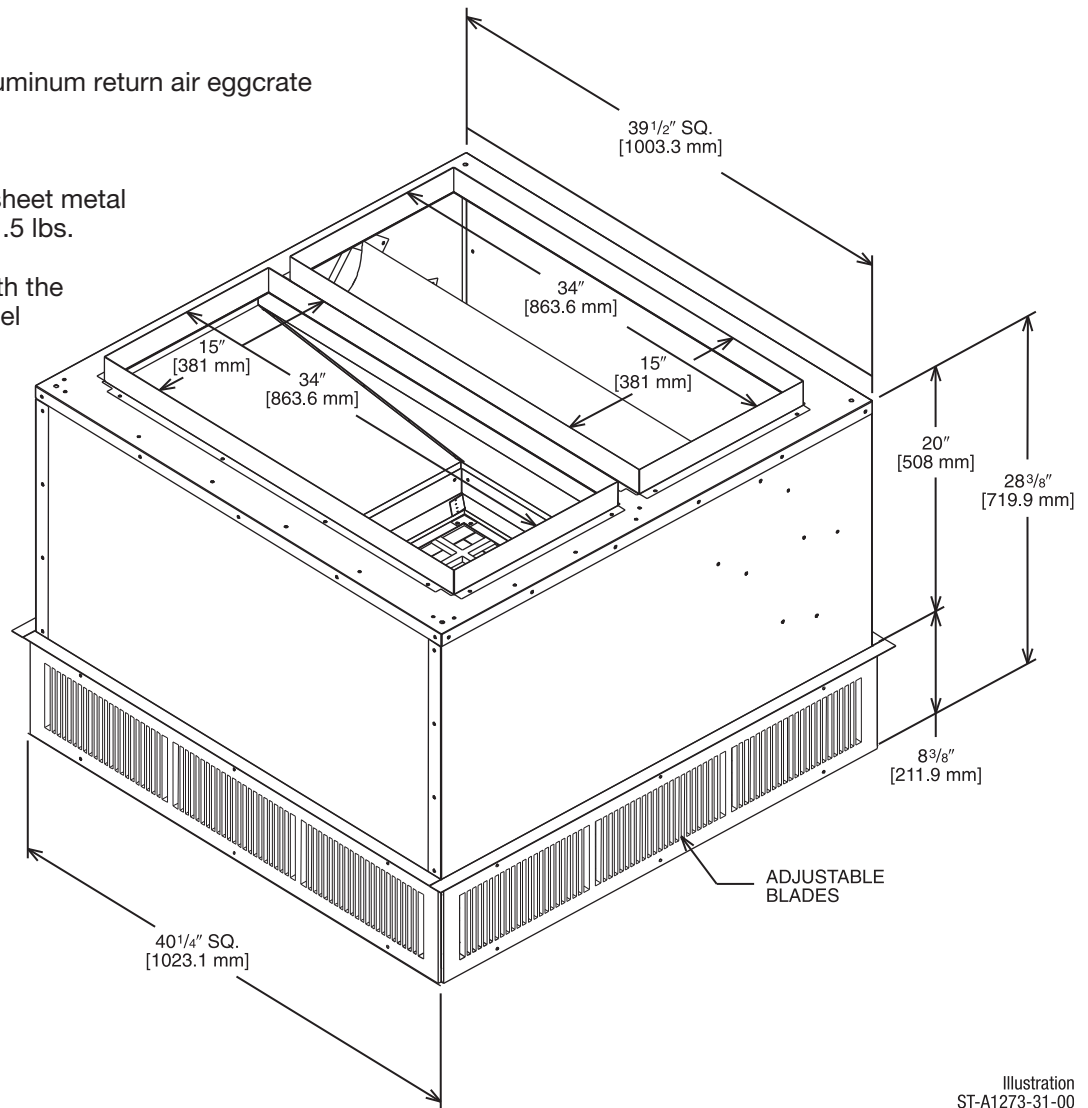

Illustration
ST-A1273-31-00

ENGINEERING DATA^①

MODEL NO.	FLOW RATE CFM [L/s]	THROW ^{②③} FEET [m]	NECK VELOCITY FPM [m/s]	NOISE LEVEL ^④ (dbA)
RXRN-AED3415	3600 [1692]	26-53 [7.9-16.2]	851 [4.3]	27
	3800 [1786]	27-55 [8.2-16.8]	898 [4.5]	29
	4000 [1880]	29-58 [8.8-17.7]	946 [4.8]	30
	4200 [1974]	31-61 [9.4-18.6]	993 [5.1]	32
	4400 [2068]	32-64 [9.8-19.5]	1040 [5.3]	33
	4600 [2162]	34-66 [10.4-20.1]	1087.5 [5.5]	35

- NOTES: ① All data is based on the air diffusion council guidelines.
 ② Throw data is based on 75 FPM Terminal Velocities using isothermal air.
 ③ Throw is based on diffuser blades being directed in a straight pattern.
 ④ Actual noise levels may vary due to duct design and do not include transmitted unit noise.
 Adequate duct attenuation must be provided to reduce sound output from the unit.

[] Designates Metric Conversions

CONCENTRIC DIFFUSER 7.5/8.5 TON FLUSH

RXRN-AEF2000

For Use With Downflow Transition (RXMC-DD01)
20" [508 mm] Round Supply and Return Ducts

- All aluminum diffuser with aluminum return air eggcrate
- Built-in anti-sweat gasket
- Molded fiberglass supports
- Built-in hanging supports
- Diffuser box constructed of sheet metal insulated with 1" [25.4 mm] 1.5 lbs. [.7 kg] duct liner

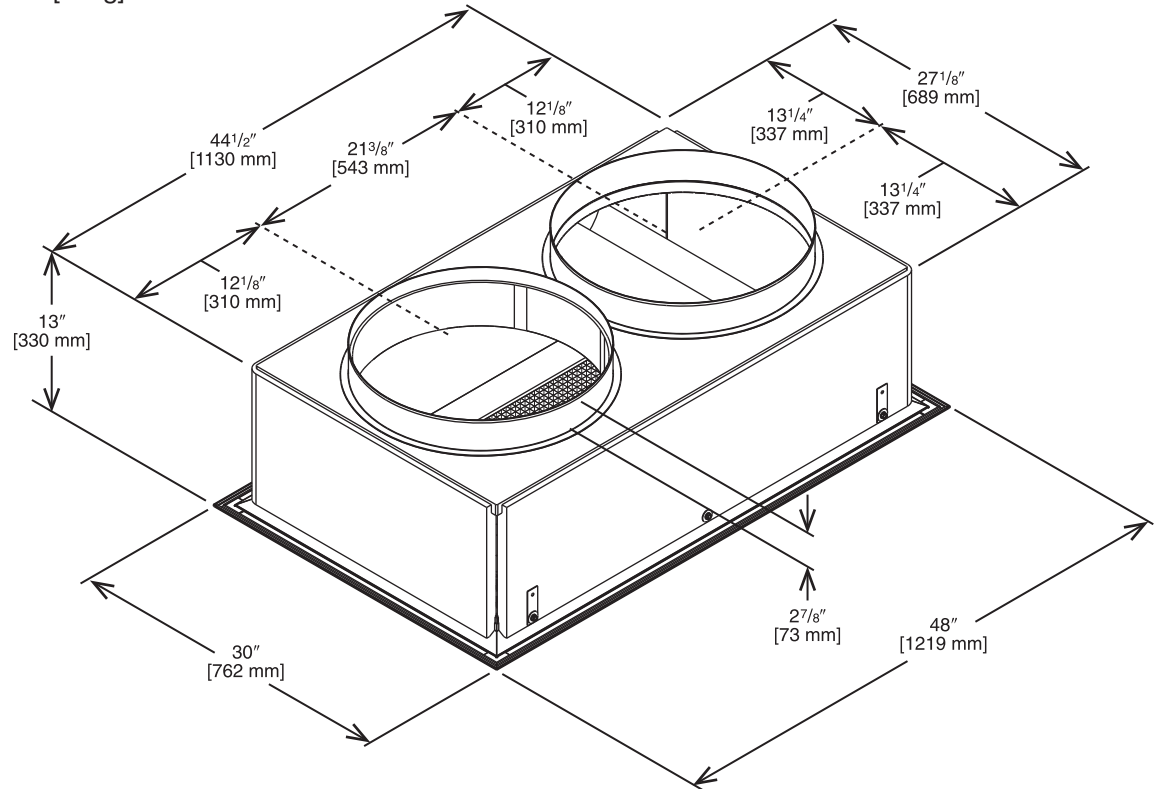

Illustration
ST-A1273-14-00

ENGINEERING DATA^①

MODEL NO.	FLOW RATE CFM [L/s]	THROW ^{② ③} FEET [m]	NECK VELOCITY FPM [m/s]	NOISE LEVEL ^④ (dba)
RXRN-AEF2000	2600 [1222]	17-24 [5.2-7.3]	663 [3.4]	30
	2800 [1316]	18-28 [5.5-8.5]	714 [3.6]	35
	3000 [1410]	20-30 [6.1-9.1]	765 [3.9]	35
	3200 [1504]	22-33 [6.7-10.1]	816 [4.1]	40
	3400 [1598]	23-37 [7-11.3]	867 [4.4]	40
	3600 [1692]	25-38 [7.6-11.6]	918 [4.7]	43
	3800 [1786]	26-39 [7.9-11.9]	969 [4.9]	45
	4000 [1880]	27-40 [8.2-12.2]	1020 [5.2]	48

NOTES: ① All data is based on the air diffusion council guidelines.

② Throw data is based on 75 FPM Terminal Velocities using isothermal air.

③ Throw is based on diffuser blades being directed in a straight pattern.

④ Actual noise levels may vary due to duct design and do not include transmitted unit noise. Adequate duct attenuation must be provided to reduce sound output from the unit.

[] Designates Metric Conversions

CONCENTRIC DIFFUSER 10.0 TON FLUSH

RXRN-AEF3415

For Use With Downflow Transition (RXMC-DD02)

15" x 34" [381 x 864 mm]

Supply and Return Ducts

- All aluminum diffuser with aluminum return air eggcrate
- Built-in anti-sweat gasket
- Molded fiberglass supports
- Built-in hanging supports
- Diffuser box constructed of sheet metal insulated with 1" [25.4 mm] 1.5 lbs. [.7 kg] duct liner

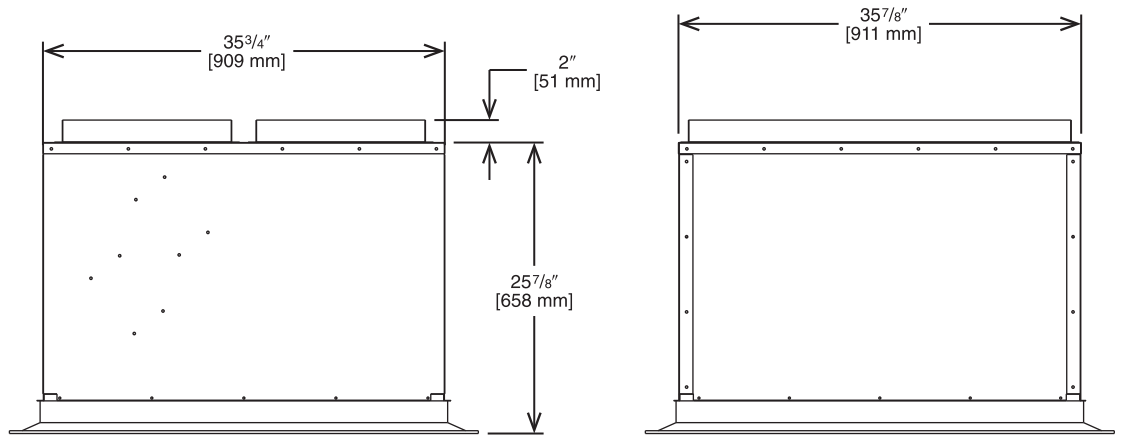
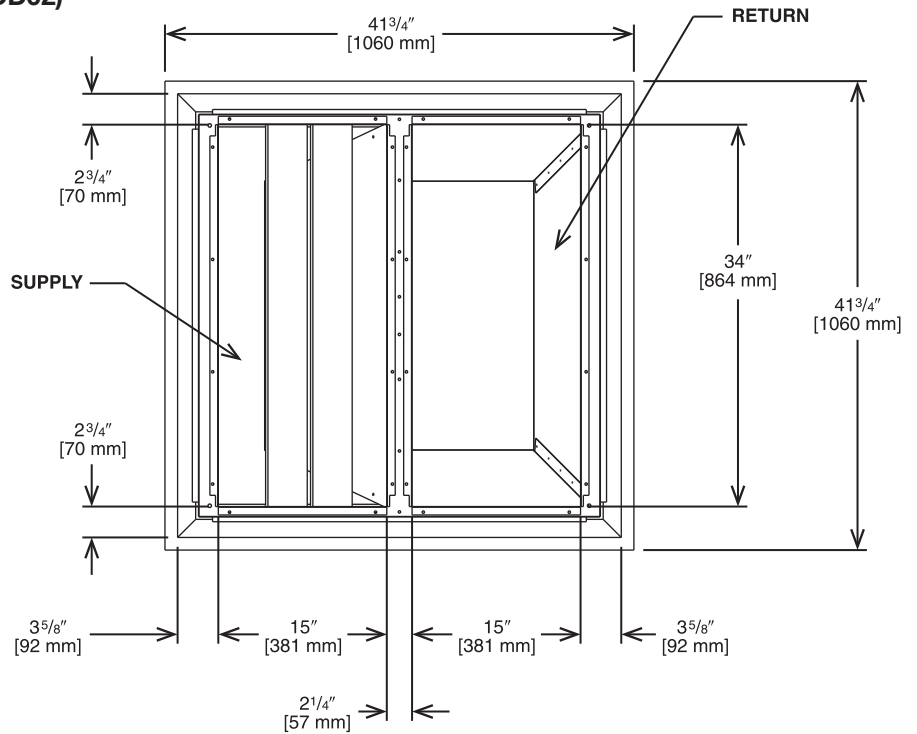

Illustration
ST-A1273-07-00

ENGINEERING DATA^①

MODEL NO.	FLOW RATE CFM [L/s]	THROW ^{② ③} FEET [m]	NECK VELOCITY FPM [m/s]	NOISE LEVEL ^④ (dbA)
RXRN-AEF3415	3600 [1692]	14-34 [4.3-10.4]	844 [4.3]	27
	3800 [1786]	15-36 [4.6-11.1]	891 [4.5]	29
	4000 [1880]	16-37 [4.9-11.3]	938 [4.8]	30
	4200 [1974]	17-39 [5.2-11.9]	985 [5.1]	32
	4400 [2068]	18-41 [5.5-12.5]	1032 [5.2]	33
	4600 [2162]	19-43 [5.8-13.1]	1079 [5.5]	35
	4800 [2256]	20-45 [6.1-13.7]	1126 [5.7]	36

NOTES: ① All data is based on the air diffusion council guidelines.

② Throw data is based on 75 FPM Terminal Velocities using isothermal air.

③ Throw is based on diffuser blades being directed in a straight pattern.

④ Actual noise levels may vary due to duct design and do not include transmitted unit noise. Adequate duct attenuation must be provided to reduce sound output from the unit.

[] Designates Metric Conversions

DDC ECONOMIZER WITH SINGLE ENTHALPY (DOWNFLOW) MICROMETL ECONOMIZER WITH HONEYWELL CONTROLLER

Field-Installed Only

RXRD-01MDDBM3
RXXR-BV02—Dual Enthalpy Kit DDC (for Honeywell DDC)
RXXR-AR02—Sensor, Carbon Dioxide (Wall Mount)

- Features **Honeywell** Controls
- Gear Driven Direct Drive Actuator
- Fully Modulating (0-100%)
- Ultra Low Leak Dampers meet California Title 24 requirements and ASHRAE 90.1 2022
- Slip-In Design for Easy Installation
- Standard Barometric Relief Damper
- Single Enthalpy with Dual Enthalpy Upgrade Kit Option
- CO₂ Input Sensor Option
- Field Assembled Hood Ships with Economizer
- Economizer Ships Complete for Downflow Duct Application
- Optional Remote Minimum Position Potentiometer (270 ohm) (Honeywell #S963B1136) is Available from Prostock
- Field-Installed Power Exhaust Option
- Prewired for Smoke Detector
- If connected to a Building Automation System (BAS), all economizer functions can be viewed on the (BAS), or 16 x 2 LCD screen
- If connected to thermostat, all economizer functions can be viewed on 16 x 2 LCD screen

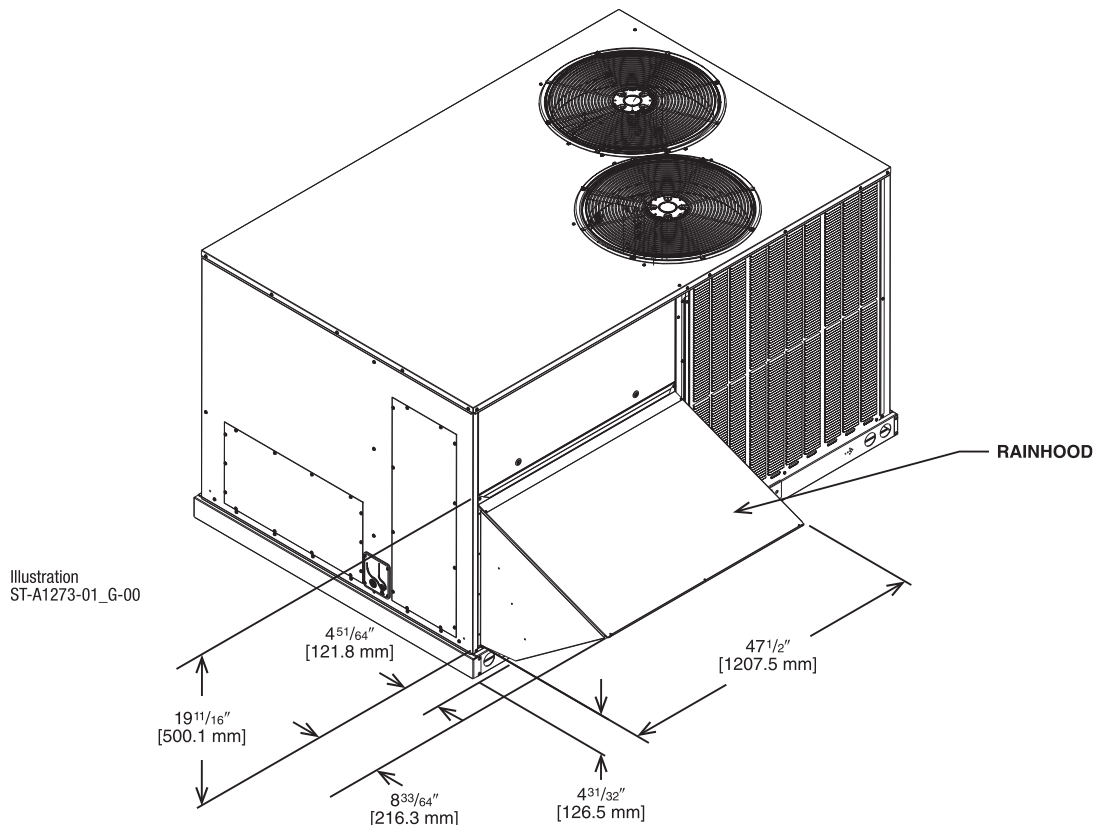
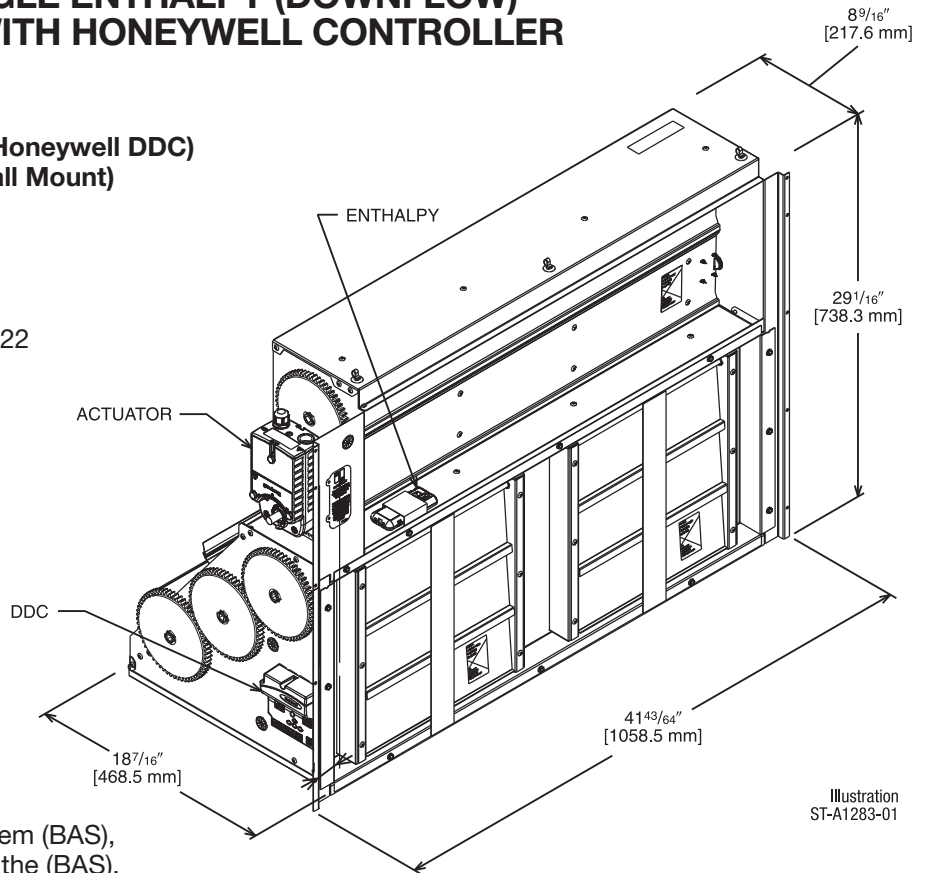

[] Designates Metric Conversions

DDC ECONOMIZER WITH SINGLE ENTHALPY (HORIZONTAL) MICROMETL ECONOMIZER WITH HONEYWELL CONTROLLER Field-Installed Only

RXRD-01MDHBM3

RRX-BV02—Dual Enthalpy Kit DDC (for Honeywell DDC)

RRX-AR02—Sensor, Carbon Dioxide (Wall Mount)

- Features **Honeywell Controls**
- Available as a Field-Installed Accessory Only
- Gear Driven Direct Drive Actuator
- Fully Modulating (0-100%)
- Ultra Low Leak Dampers meet California Title 24 requirements and ASHRAE 90.1 2022
- Slip-In Design for Easy Installation
- Standard Barometric Relief Damper
- Single Enthalpy with Dual Enthalpy Upgrade Kit Option
- CO₂ Input Sensor Option
- Field Assembled Hood Ships with Economizer
- Economizer Ships Complete for Horizontal Duct Application
- Optional Remote Minimum Position Potentiometer (270 ohm) (Honeywell #S963B1136) is Available from Prostock
- Field-Installed Power Exhaust Option
- If connected to a Building Automation System (BAS), all economizer functions can be viewed on the (BAS), or 16 x 2 LCD screen
- If connected to thermostat, all economizer functions can be viewed on 16 x 2 LCD screen

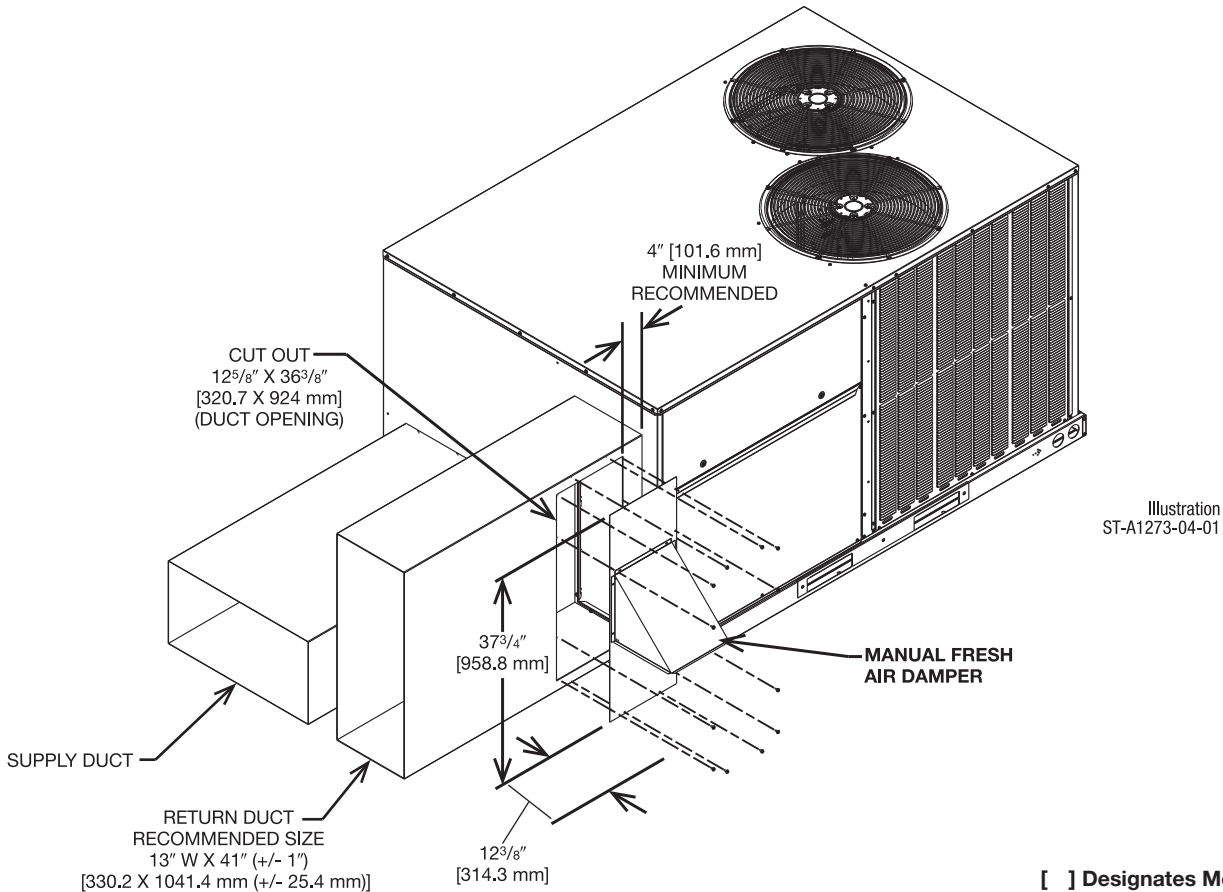
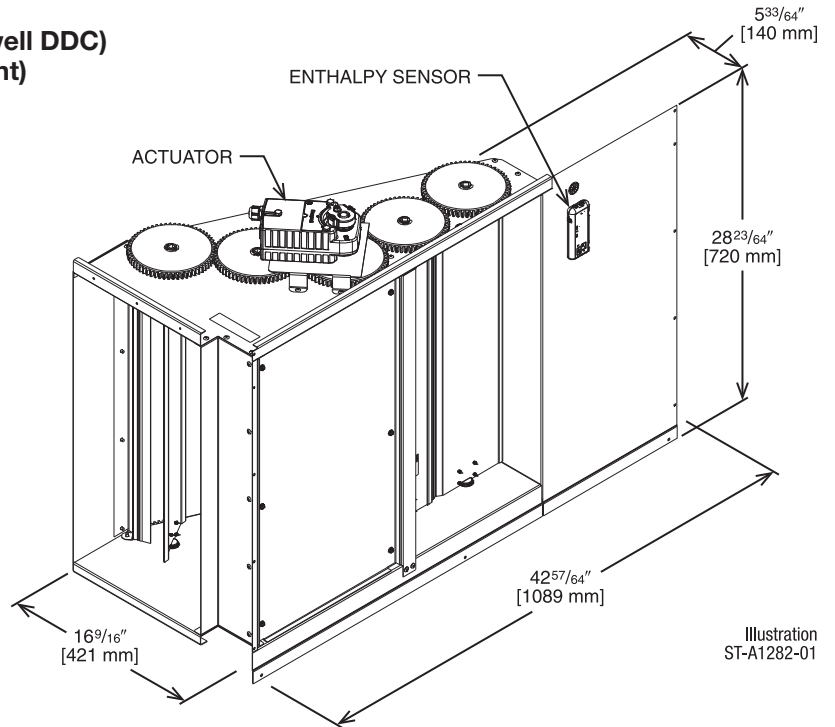

[] Designates Metric Conversions

NON-DDC ECONOMIZER WITH NO CONTROLS (DOWNFLOW) MICROMETL ECONOMIZER, BELIMO ACTUATOR Field-Installed Only

RXRD-31MDDAM3

RXXR-ACD01 – Wire Harness for Non-DDC Generic Economizers

- Gear Driven Direct Drive Actuator
- Fully Modulating (0-100%)
- Ultra Low Leak Dampers meet California Title 24 requirements and ASHRAE 90.1 2022
AMCA 511 Certified Class 1A Leakage—1" WG of differential pressure tested to AMCA Standard 500-D
- Slip-In Design for Easy Installation
- Plug-In Polarized 12-pin Electrical Connections
- Standard Barometric Relief Damper
- Controller and Sensors to be determined by Customer
- Field Assembled Hood Ships with Economizer
- Economizer Ships Complete for Downflow Duct Application
- Field-Installed Power Exhaust Option

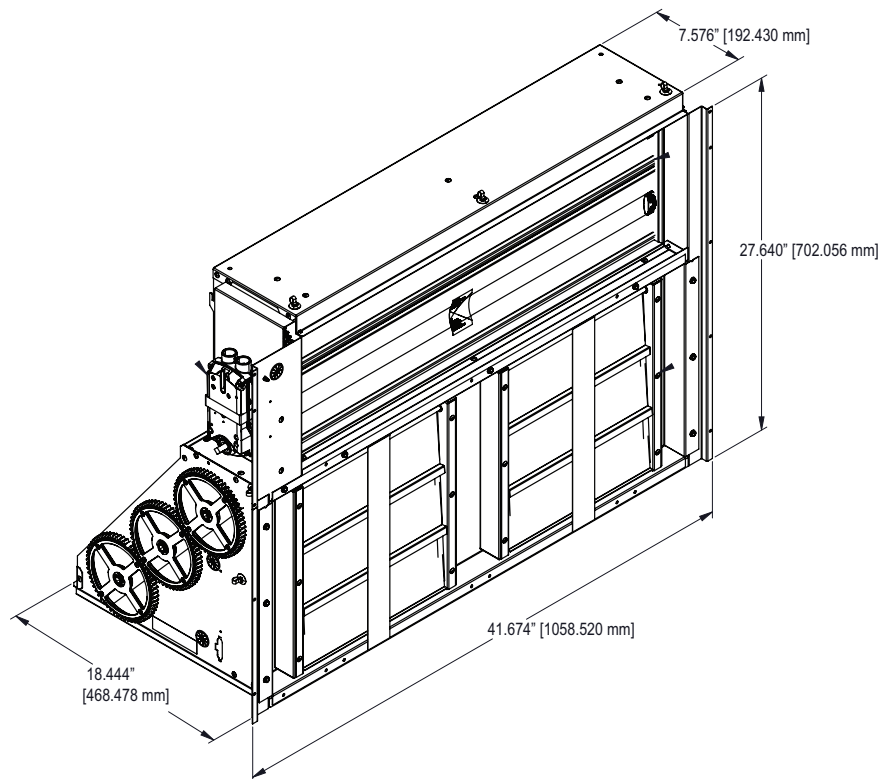

[] Designates Metric Conversions

NON-DDC ECONOMIZER WITH SINGLE ENTHALPY (DOWNFLOW) MICROMETL ECONOMIZER WITH SIEMENS CONTROLS

Factory or Field-Installed

RXRD-11MDDAM3

PD555460—Dual Enthalpy, Temperature and Humidity Sensor (for Siemens Controller)

RRX-AR02—Sensor, Carbon Dioxide (Wall Mount)

- Features **Siemens** Controls
- Available Factory-Installed or Field Accessory
- Gear Driven Direct Drive Actuator
- Fully Modulating (0-100%)
- Ultra Low Leak Dampers meet California Title 24 requirements and ASHRAE 90.1 2022
- Slip-In Design for Easy Installation
- Standard Barometric Relief Damper
- Single Enthalpy with Dual Enthalpy Upgrade Kit Available
- CO₂ Input Sensor Option
- Field Assembled Hood Ships with Economizer
- Economizer Ships Complete for Downflow Duct Application
- Field-Installed Power Exhaust Option
- Prewired for Smoke Detector
- If connected to a Building Automation System (BAS), all economizer functions can be viewed on the (BAS) or 16 x 2 LCD screen
- If connected to thermostat, all economizer functions can be viewed on 16 x 2 LCD screen

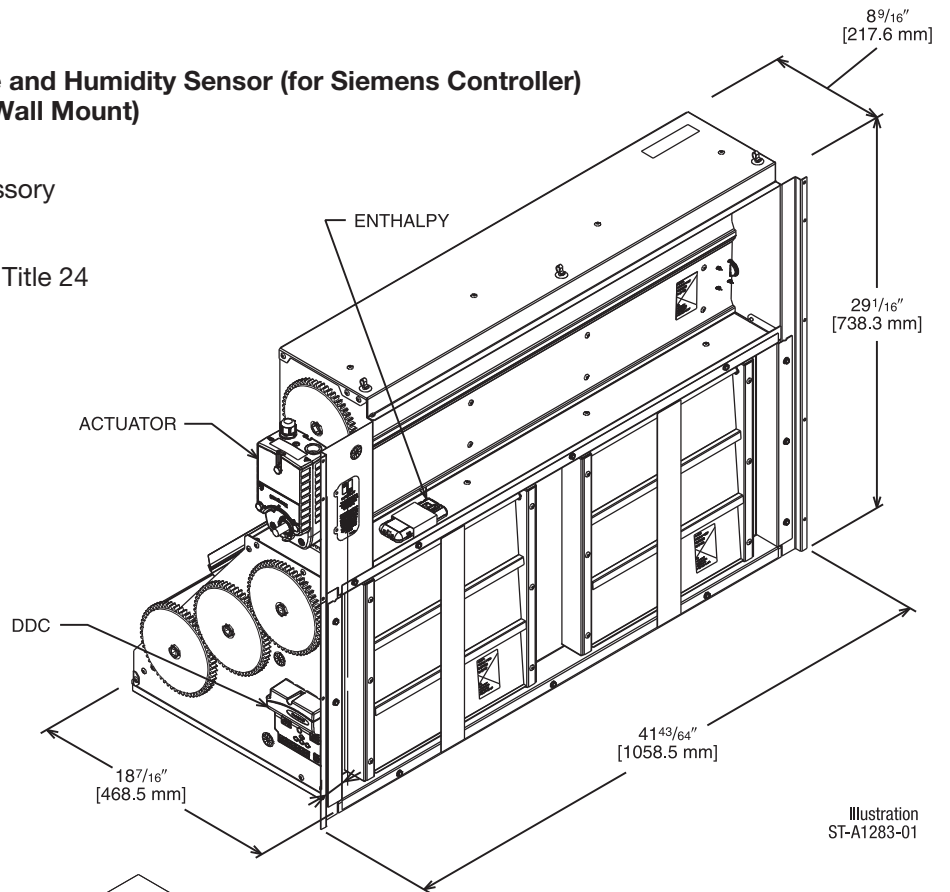

Illustration
ST-A1283-01

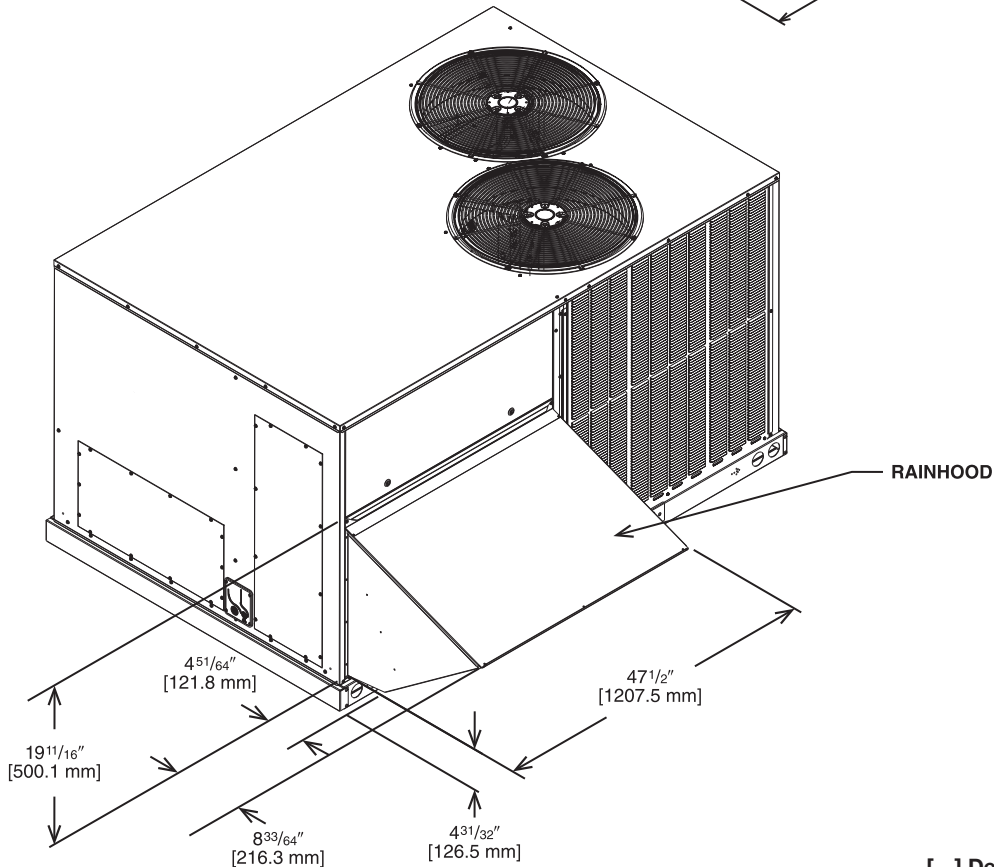

Illustration
ST-A1273-01_G-00

[] Designates Metric Conversions

NON-DDC ECONOMIZER WITH SINGLE ENTHALPY (DOWNFLOW) RUSKIN ROOFTOP SYSTEMS ECONOMIZER WITH RRS BASIC CONTROLLER

Factory or Field-Installed

RXRD-41MDDAM3

PD955977—Temperature and Humidity Sensor for Dual Enthalpy (for Ruskin Basic Controller)

RXXR-AR02—Sensor, Carbon Dioxide (Wall Mount)

These ultra-low leak economizer dampers meet the following minimum construction standards:

1. Frame shall be 14 to 24 gauge galvanized steel channel.
2. Damper blades are galvanized steel airfoil shaped, double skin construction of 14 gauge [2.0] equivalent thickness, 6" [152 mm] wide. Parallel action.
3. Blade edge seals shall be Ruskiprene™ type or equivalent suitable for -72°F [-60°C] to +275°F [+135°C] mechanically locked into the blade edge. Adhesive or clip-on type seals are unacceptable.
4. Jamb seals shall be flexible metal, compression type to prevent leakage between blade end and damper frame. Blade end overlapping frame is unacceptable.
5. Bearings shall be stainless steel or nylon bushing.
6. Axles shall be hexagonal positively locked into the damper blade.
7. Drive mechanism shall be concealed out of airstream to reduce pressure drop and noise.
8. Economizer damper is tested and rated based upon AMCA Publication 500-D.
9. RRS controls feature the Basic economizer controller with 24V actuator. Controls capable of Economizer Fault Detection and Diagnostics for code compliance.
10. Damper shall meet the leakage requirements of the International Energy Conservation Code by leaking less than 3 cfm/sq. ft. at 1" of static pressure and shall be AMCA licensed as a class 1A damper. Complies with reliability and performance requirements as specified by the California Energy Commission's Title 24 Standard and ASHRAE 90.1 2022. Economizer dampers shall be Ruskin Rooftop Systems ECD60 model.
11. Can be Converted to DDC Operation with the Economizer Universal DDC Interface Kit (RXXR-DDC01).

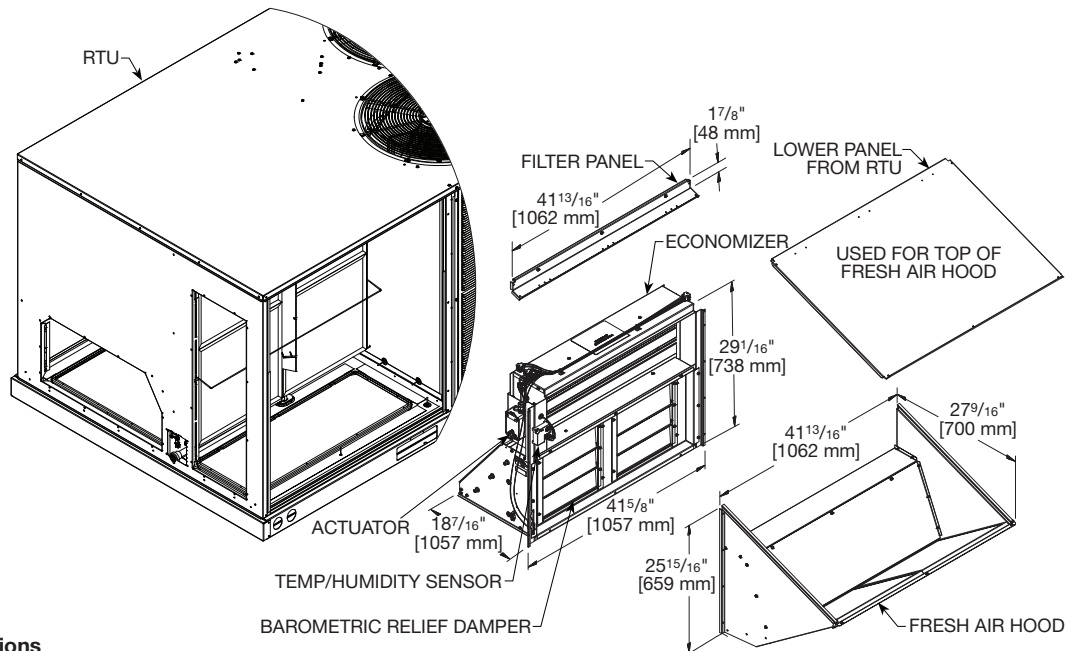

[] Designates Metric Conversions

NON-DDC ECONOMIZER WITH SINGLE ENTHALPY (DOWNFLOW) RUSKIN ROOFTOP SYSTEMS ECONOMIZER WITH SIEMENS CONTROLLER

Factory or Field-Installed

RXRD-51MDDAM3

PD555460—Dual Enthalpy, Temperature and Humidity Sensor (for Siemens Controller)

RRX-AR02—Sensor, Carbon Dioxide (Wall Mount)

These ultra-low leak economizer dampers meet the following minimum construction standards:

1. Frame shall be 14 to 24 gauge galvanized steel channel.
2. Damper blades are galvanized steel airfoil shaped, double skin construction of 14 gauge [2.0] equivalent thickness, 6" [152 mm] wide. Parallel action.
3. Blade edge seals shall be Ruskiprene™ type or equivalent suitable for -72°F [-60°C] to +275°F [+135°C] mechanically locked into the blade edge. Adhesive or clip-on type seals are unacceptable.
4. Jamb seals shall be flexible metal, compression type to prevent leakage between blade end and damper frame. Blade end overlapping frame is unacceptable.
5. Bearings shall be stainless steel or nylon bushing.
6. Axles shall be hexagonal positively locked into the damper blade.
7. Drive mechanism shall be concealed out of airstream to reduce pressure drop and noise.
8. Economizer damper is tested and rated based upon AMCA Publication 500-D.
9. Controls feature the Siemens controller with Siemens 24V actuator. Controls capable of Economizer Fault Detection and Diagnostics for code compliance.
10. Damper shall meet the leakage requirements of the International Energy Conservation Code by leaking less than 3 cfm/sq. ft. at 1" of static pressure and shall be AMCA licensed as a class 1A damper. Complies with reliability and performance requirements as specified by the California Energy Commission's Title 24 Standard and ASHRAE 90.1 2022. Economizer dampers shall be Ruskin Rooftop Systems ECD60 model.
11. Can be Converted to DDC Operation with the Economizer Universal DDC Interface Kit (RXRX-DDC01).

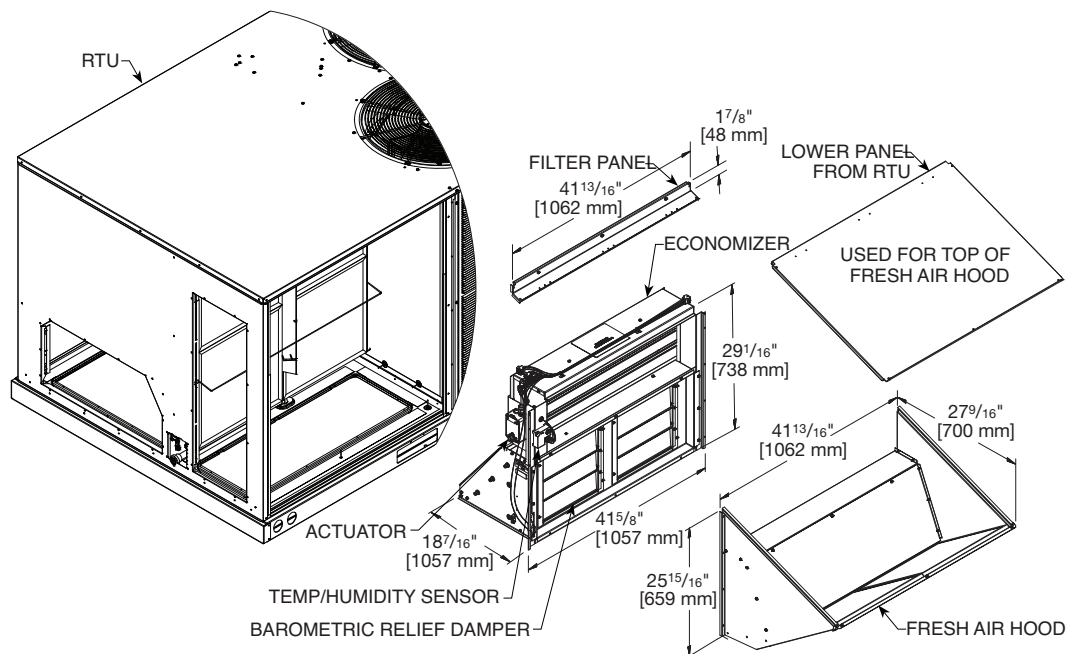

[] Designates Metric Conversions

NON-DDC ECONOMIZER WITH SINGLE ENTHALPY (HORIZONTAL) MICROMETL ECONOMIZER WITH SIEMENS CONTROLS

Field-Installed Only

RXRD-11MDHAM3

PD555460—Dual Enthalpy, Temperature and Humidity Sensor (for Siemens Controller)

RXR-AR02—Sensor, Carbon Dioxide (Wall Mount)

- Features **Siemens** Controls
- Gear Driven Direct Drive Actuator
- Fully Modulating (0-100%)
- Low Leakage Dampers
- Slip-In Design for Easy Installation
- Standard Barometric Relief Damper
- Single Enthalpy with Dual Enthalpy Upgrade Kit Available
- CO₂ Input Sensor Option
- Field Assembled Hood Ships with Economizer
- Economizer Ships Complete for Horizontal Duct Application
- Field-Installed Power Exhaust Option
- If connected to a Building Automation System (BAS), all economizer functions can be viewed on the (BAS) or 16 x 2 LCD screen
- If connected to thermostat, all economizer functions can be viewed on 16 x 2 LCD screen
- Can be Converted to DDC Operation with the Economizer Universal DDC Interface Kit (RXRX-DDC01)

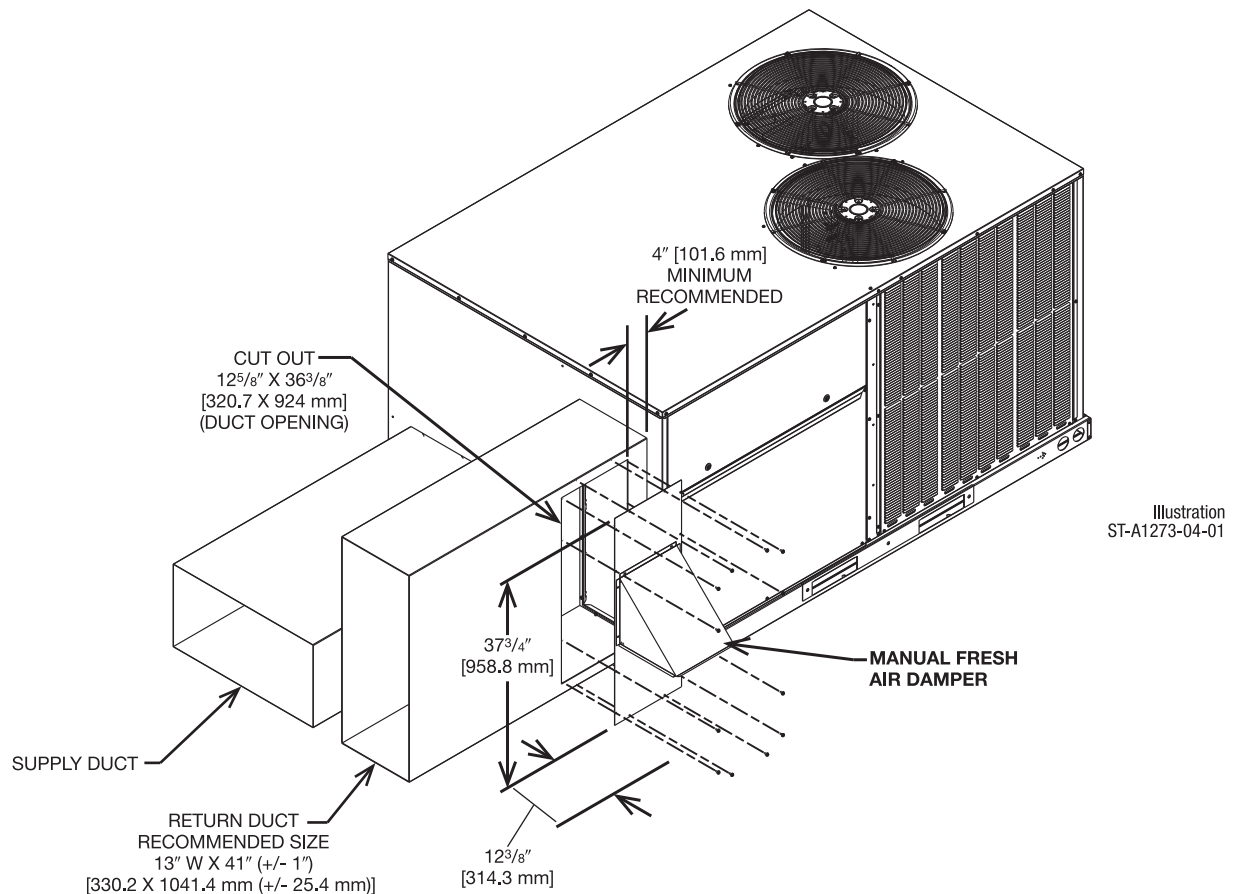
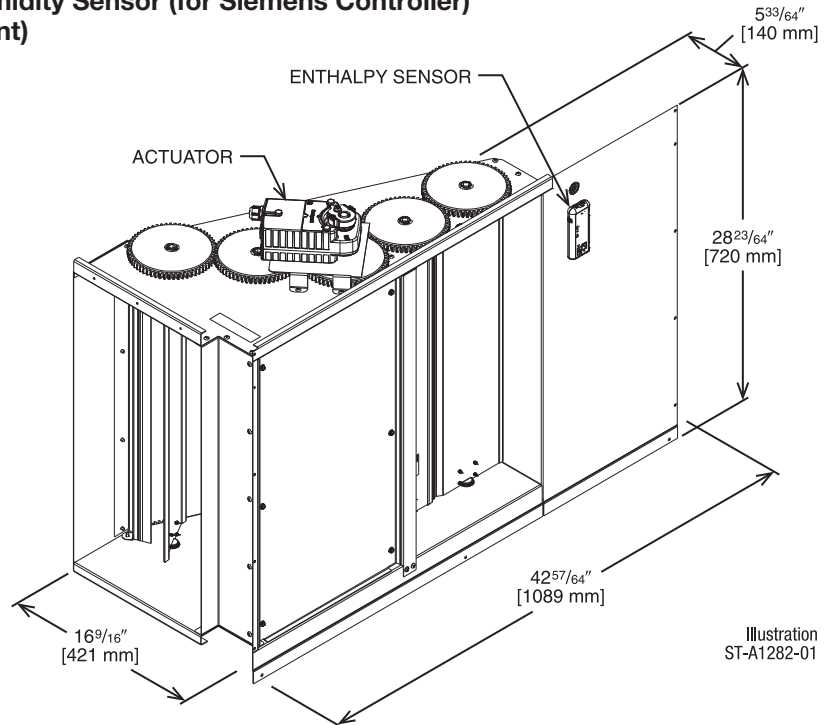

[] Designates Metric Conversions

NON-DDC ECONOMIZER WITH SINGLE ENTHALPY (HORIZONTAL) RUSKIN ROOFTOP SYSTEMS ECONOMIZER WITH RRS BASIC CONTROLLER

Field-Installed Only

RXRD-41MDHAM3

PD955977 – Dual Enthalpy, Temperature and Humidity Sensor (for Ruskin Basic Controller)

RRX-AR02 – Sensor, Carbon Dioxide (Wall Mount)

These ultra-low leak economizer dampers meet the following minimum construction standards:

1. Frame shall be 14 to 24 gauge galvanized steel channel.
2. Damper blades are galvanized steel airfoil shaped, double skin construction of 14 gauge [2.0] equivalent thickness, 6" [152 mm] wide. Parallel action.
3. Blade edge seals shall be Ruskiprene™ type or equivalent suitable for -72°F [-60°C] to +275°F [+135°C] mechanically locked into the blade edge. Adhesive or clip-on type seals are unacceptable.
4. Jamb seals shall be flexible metal, compression type to prevent leakage between blade end and damper frame. Blade end overlapping frame is unacceptable.
5. Bearings shall be stainless steel or nylon bushing.
6. Axles shall be hexagonal positively locked into the damper blade.
7. Drive mechanism shall be concealed out of airstream to reduce pressure drop and noise.
8. Economizer damper is tested and rated based upon AMCA Publication 500-D.
9. RRS controls feature the Basic economizer controller with 24V actuator. Controls capable of Economizer Fault Detection and Diagnostics for code compliance.
10. Damper shall meet the leakage requirements of the International Energy Conservation Code by leaking less than 3 cfm/sq. ft. at 1" of static pressure and shall be AMCA licensed as a class 1A damper. Complies with reliability and performance requirements as specified by the California Energy Commission's Title 24 Standard and ASHRAE 90.1 2022. Economizer dampers shall be Ruskin Rooftop Systems ECD60 model.
11. Can be Converted to DDC Operation with the Economizer Universal DDC Interface Kit (RXRX-DDC01).

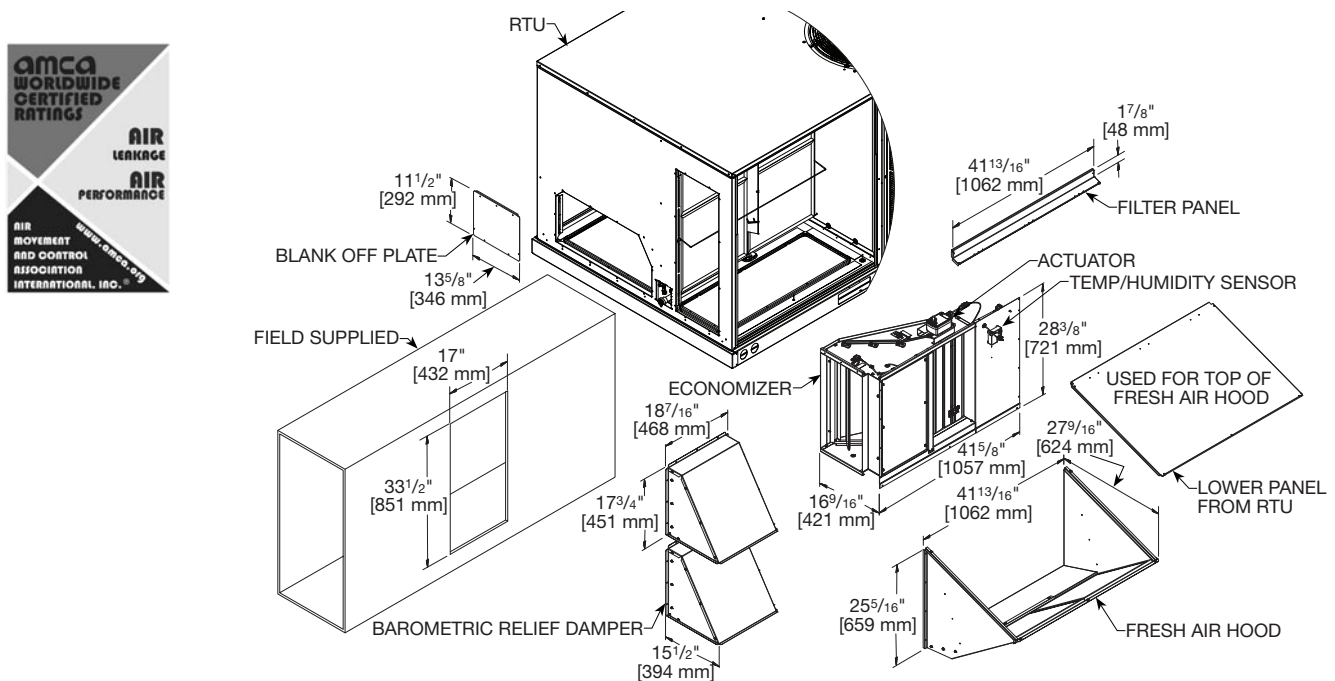

[] Designates Metric Conversions

NON-DDC ECONOMIZER W/SINGLE ENTHALPY (HORIZONTAL) RUSKIN ROOFTOP SYSTEMS ECONOMIZER WITH SIEMENS CONTROLLER

Field-Installed

RXRD-51MDHAM3

PD555460—Dual Enthalpy, Temperature and Humidity Sensor (for Siemens Controller)

RXXR-AR02—Sensor, Carbon Dioxide (Wall Mount)

These ultra-low leak economizer dampers meet the following minimum construction standards:

1. Frame shall be 14 to 24 gauge galvanized steel channel.
2. Damper blades are galvanized steel airfoil shaped, double skin construction of 14 gauge [2.0] equivalent thickness, 6" [152 mm] wide. Parallel action.
3. Blade edge seals shall be Ruskiprene™ type or equivalent suitable for -72°F [-60°C] to +275°F [+135°C] mechanically locked into the blade edge. Adhesive or clip-on type seals are unacceptable.
4. Jamb seals shall be flexible metal, compression type to prevent leakage between blade end and damper frame. Blade end overlapping frame is unacceptable.
5. Bearings shall be stainless steel or nylon bushing.
6. Axles shall be hexagonal positively locked into the damper blade.
7. Drive mechanism shall be concealed out of airstream to reduce pressure drop and noise.
8. Economizer damper is tested and rated based upon AMCA Publication 500-D.
9. Controls feature the Siemens controller with Siemens 24V actuator. Controls capable of Economizer Fault Detection and Diagnostics for code compliance.
10. Damper shall meet the leakage requirements of the International Energy Conservation Code by leaking less than 3 cfm/sq. ft. at 1" of static pressure and shall be AMCA licensed as a class 1A damper. Complies with reliability and performance requirements as specified by the California Energy Commission's Title 24 Standard and ASHRAE 90.1 2022. Economizer dampers shall be Ruskin Rooftop Systems ECD60 model.
11. Can be Converted to DDC Operation with the Economizer Universal DDC Interface Kit (RXXR-DDC01).

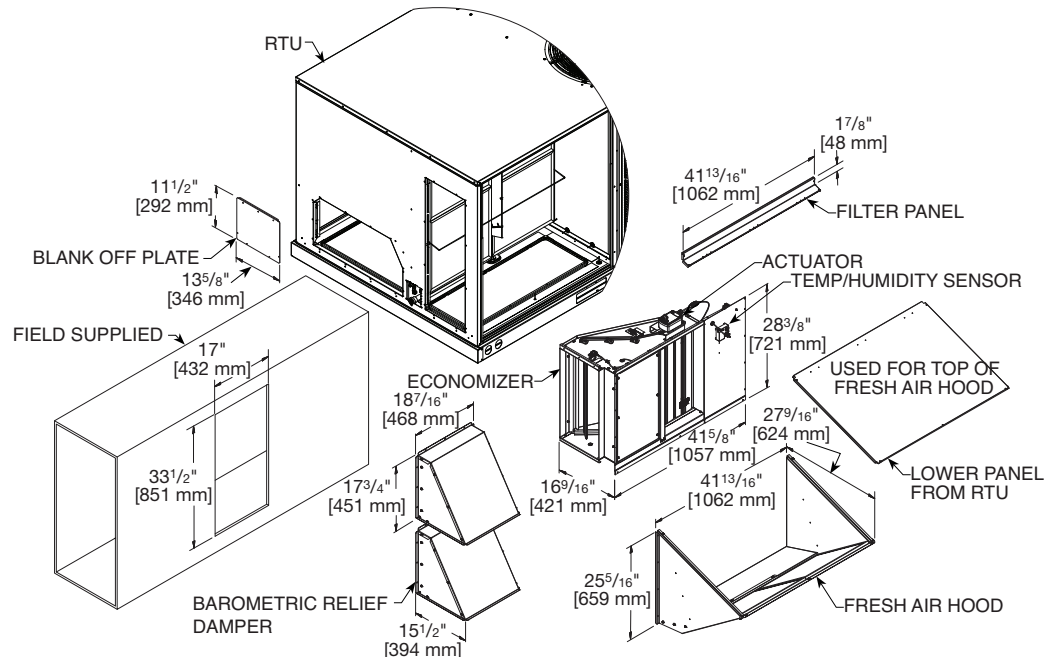

[] Designates Metric Conversions

ECONOMIZER UNIVERSAL DDC INTERFACE KIT

Available Factory or Field-Installed

RXRX-DDC01

- Allows any Non-DDC Economizer to be used with a ClearControl DDC model
- Mounts on the Economizer
- Provides Mounting location for Economizer Controller
- Provides wire management for excess wire

NOTE: Older DDC Models, prior to R-454B refrigerant models, may require a field update to the ClearControl software. The minimum version required is 3.15. Models using R-454B refrigerant will come with software version 4.0 or higher.

HORIZONTAL FLOW DDC BRACKET SETUP

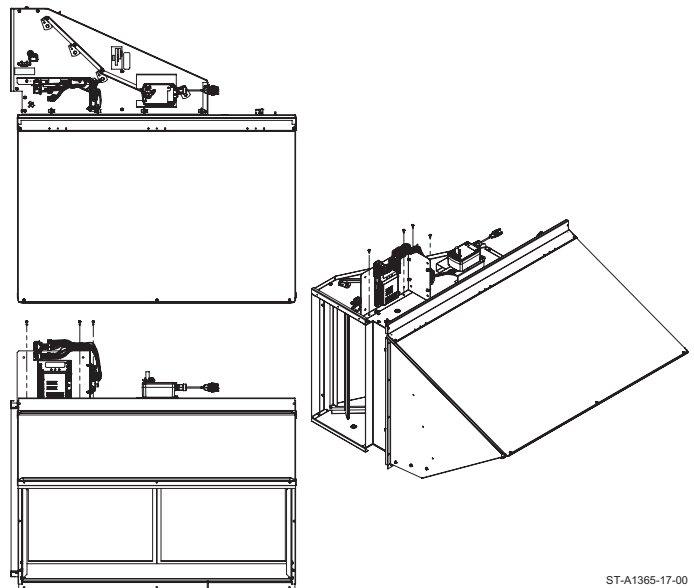

ST-A1365-17-00

DOWNFLOW ECONOMIZER DDC BRACKET SETUP

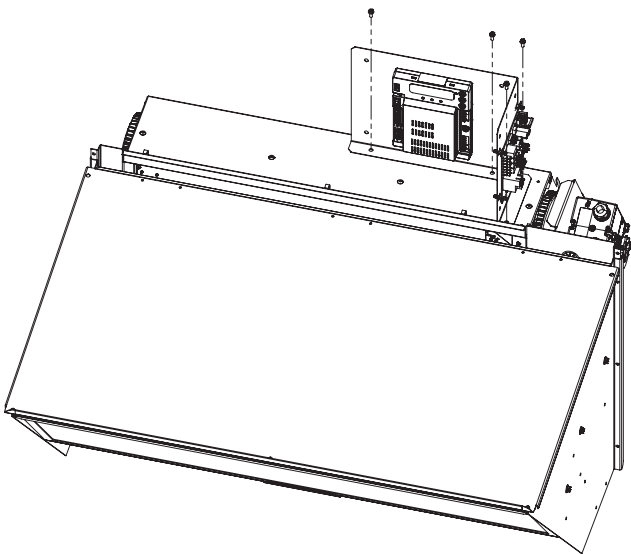

ST-A1365-13-01

FRESH AIR DAMPER

FRESH AIR DAMPER, MANUAL
RXRF-ADA1

DOWNFLOW APPLICATION

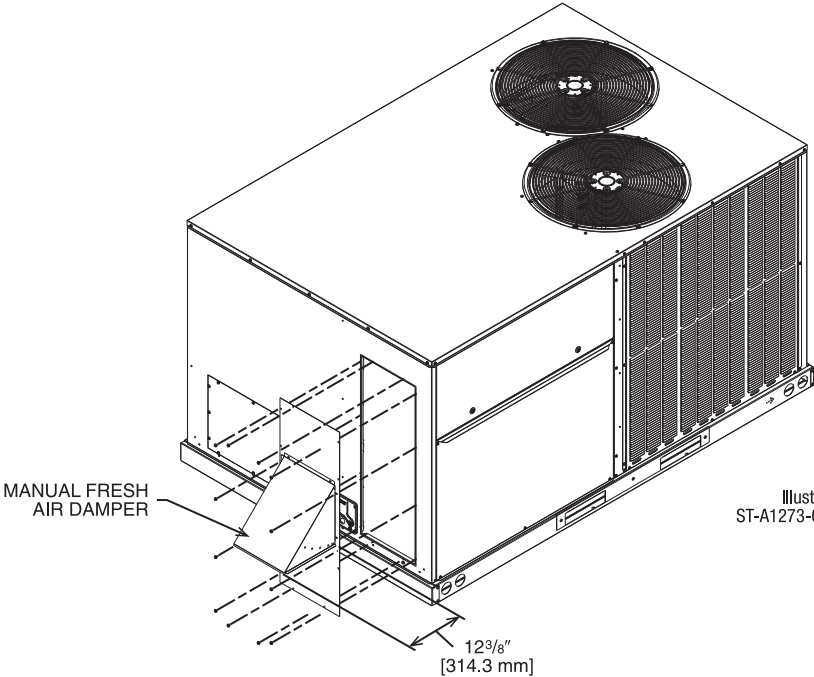

Illustration
ST-A1273-03-00

HORIZONTAL APPLICATION

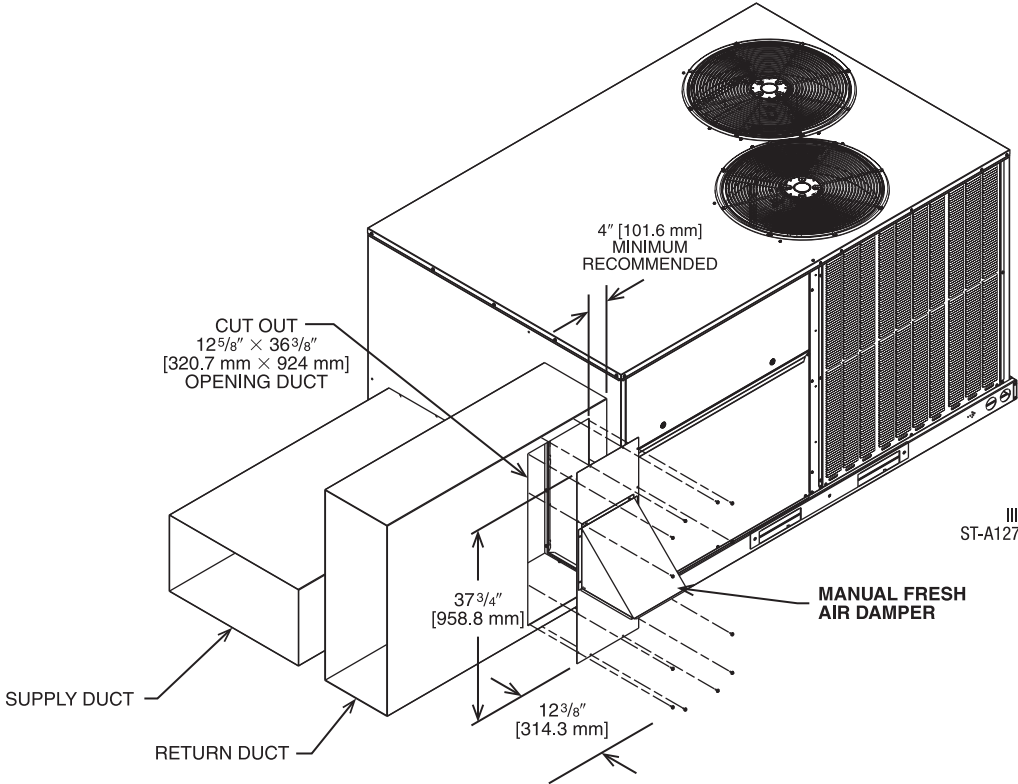

Illustration
ST-A1273-04-00

[] Designates Metric Conversions

FRESH AIR DAMPER (CONTINUED)

FRESH AIR DAMPER, MOTORIZED RXRF-ADB1

FRESH AIR DAMPER, MOTORIZED (DDC) RXRF-ADC1

Modulating Motor Kit with position feedback for DDC Models

- Features **Honeywell** Controls
- Gear Driven Direct Drive Actuator
- Fully Modulating (0-100%)
- Low Leakage Dampers
- Slip-In Design for Easy Installation
- Plug-In Polarized 12-pin and 4-pin Electrical Connections
- Pre-Configured—No Field Adjustments Necessary
- Addition of Dual Enthalpy Upgrade Kit allows limited economizer function
- CO₂ Sensor Input Available for Demand Control Ventilation (DCV)
- Optional Remote Minimum Position Potentiometer (270 ohm) (Honeywell #S963B1136) is available from Prostock
- All fresh air damper functions can be viewed at the RTU-C unit controller display
- If connected to a Building Automation System (BAS), all fresh air damper functions can be viewed on a 16 character, 2 row LCD screen
- If connected to thermostat, all fresh air damper functions can be viewed on a 16 character, 2 row LCD screen.

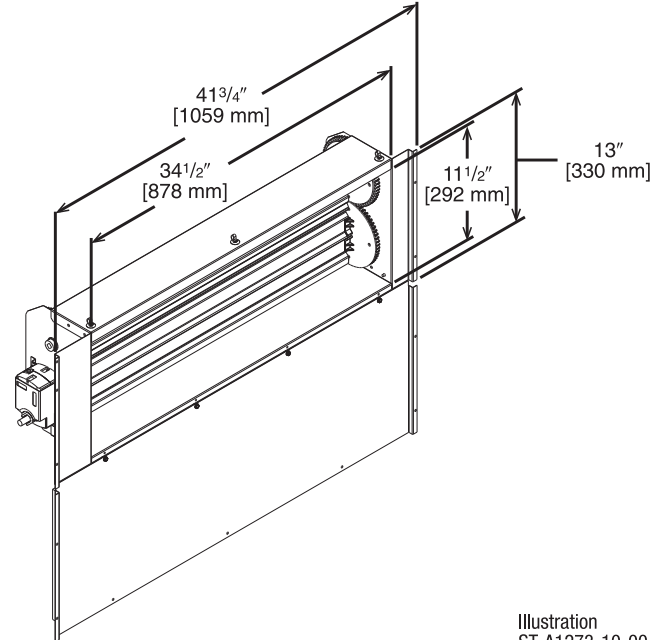

Illustration
ST-A1273-10-00

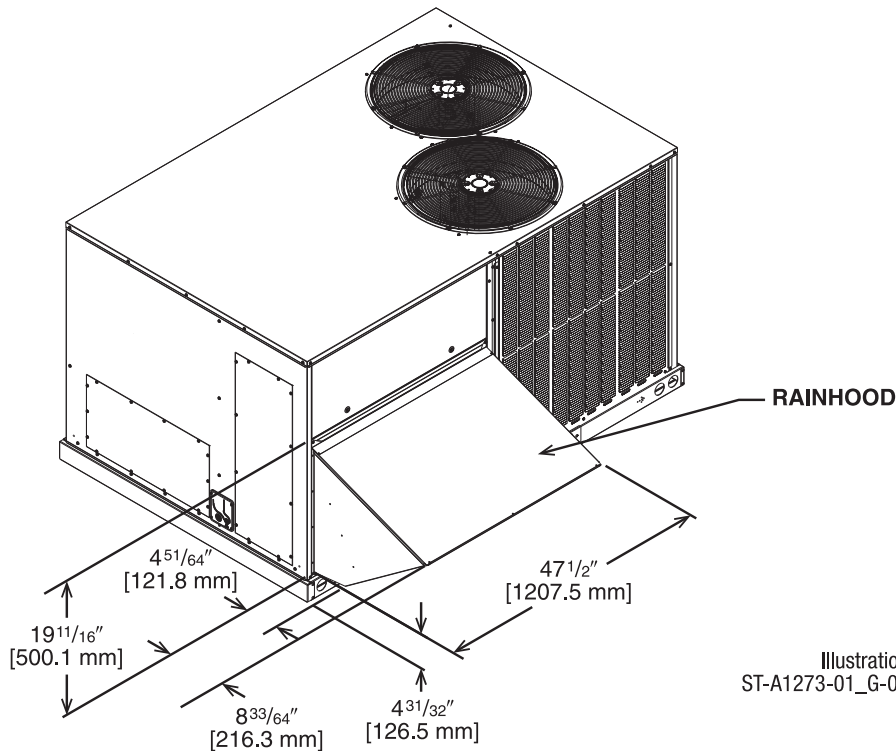

Illustration
ST-A1273-01_G-00

[] Designates Metric Conversions

POWER EXHAUST KIT, CONVERTIBLE

RXRX-CDF01*

*Voltage Code: C or D

- Convertible between vertical airflow and horizontal airflow
- Compatible with all D-cabinet economizers
- Economizer sold separately

VERTICAL AIRFLOW INSTALLATION

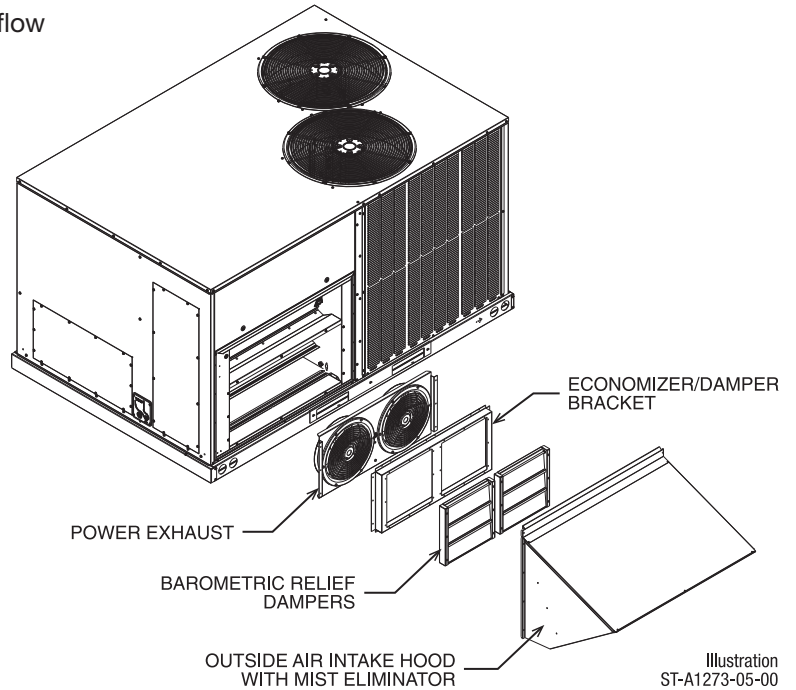

Illustration
ST-A1273-05-00

HORIZONTAL AIRFLOW INSTALLATION

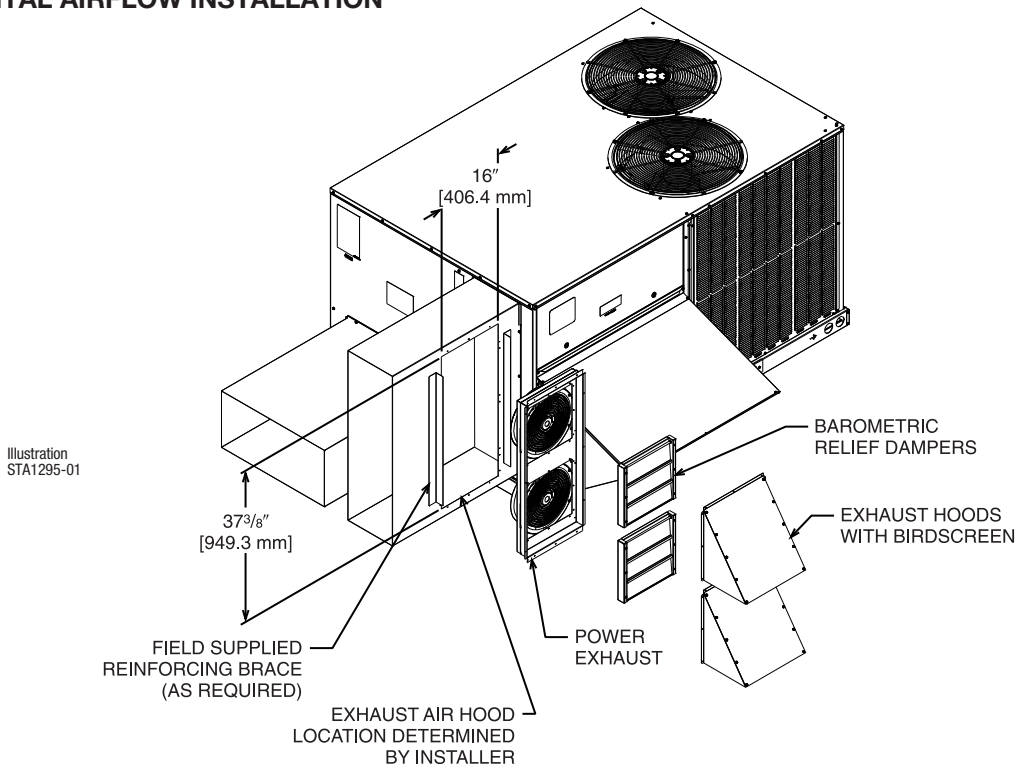

Illustration
STA1295-01

MODEL NO.	NO. OF FANS	VOLTS	PHASE	HP (ea.)	CFM [L/s]*	RPM	FLA (ea.)	LRA (ea.)
RXRX-CDF01C	2	208-230	1	0.47	2200	3000	1.55	1.1
RXRX-CDF01D	2	460	3	0.40	1970	2750	0.51	1.9

*CFM is per fan at 0" w.c. external static pressure.

[] Designates Metric Conversions

POWER EXHAUST KIT FOR DOWNFLOW ECONOMIZER

RXRX-RDF01*

*Voltage Code: C or D

- Shipped completely assembled
- All wiring from control box to economizer is supplied
- Color coordinated with the unit
- Fully insulated with 1" 1.5 lb. fiberglass insulation
- Motors are factory wired and tested
- When using this power exhaust system, clearance between the bottom of the unit and finished roof deck should be a minimum of 10 inches. Some applications may require a taller roof curb for proper installation
- **Economizer Sold Separately**

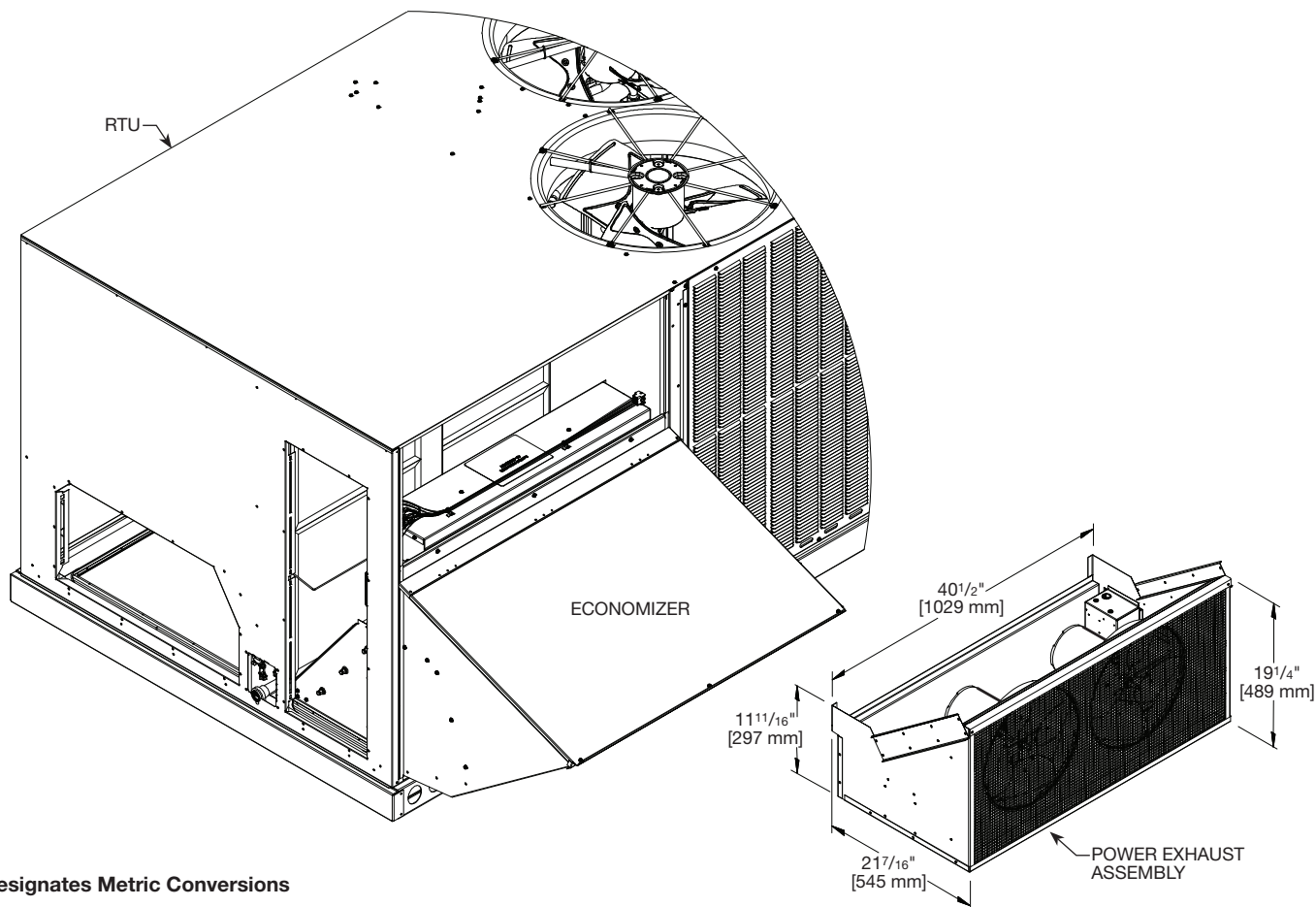

[] Designates Metric Conversions

MODEL NO.	VOLT	PHASE	MOTOR				UNIT				@ 0.1 CFM
			HP	RPM	LRA	QTY.	CIR. QTY.	FLA	MCA	FUSE SIZE	
RXRX-RDF01C	208/230	1	1/2	1625	5.86	2	1	5.40	6.75	8	4013
RXRX-RDF01D	460				3.33			2.68	3.35	4	

POWER EXHAUST KIT FOR HORIZONTAL ECONOMIZER

RXXR-RDF03*

*Voltage Code: C or D

- Shipped completely assembled
- All wiring from control box to economizer is supplied
- Color coordinated with the unit
- Fully insulated with 1" 1.5 lb. fiberglass insulation
- Motors are factory wired and tested
- When using this power exhaust system, clearance between the bottom of the unit and finished roof deck should be a minimum of 10 inches. Some applications may require a taller roof curb for proper installation
- **Economizer with Relief Hood Sold Separately**

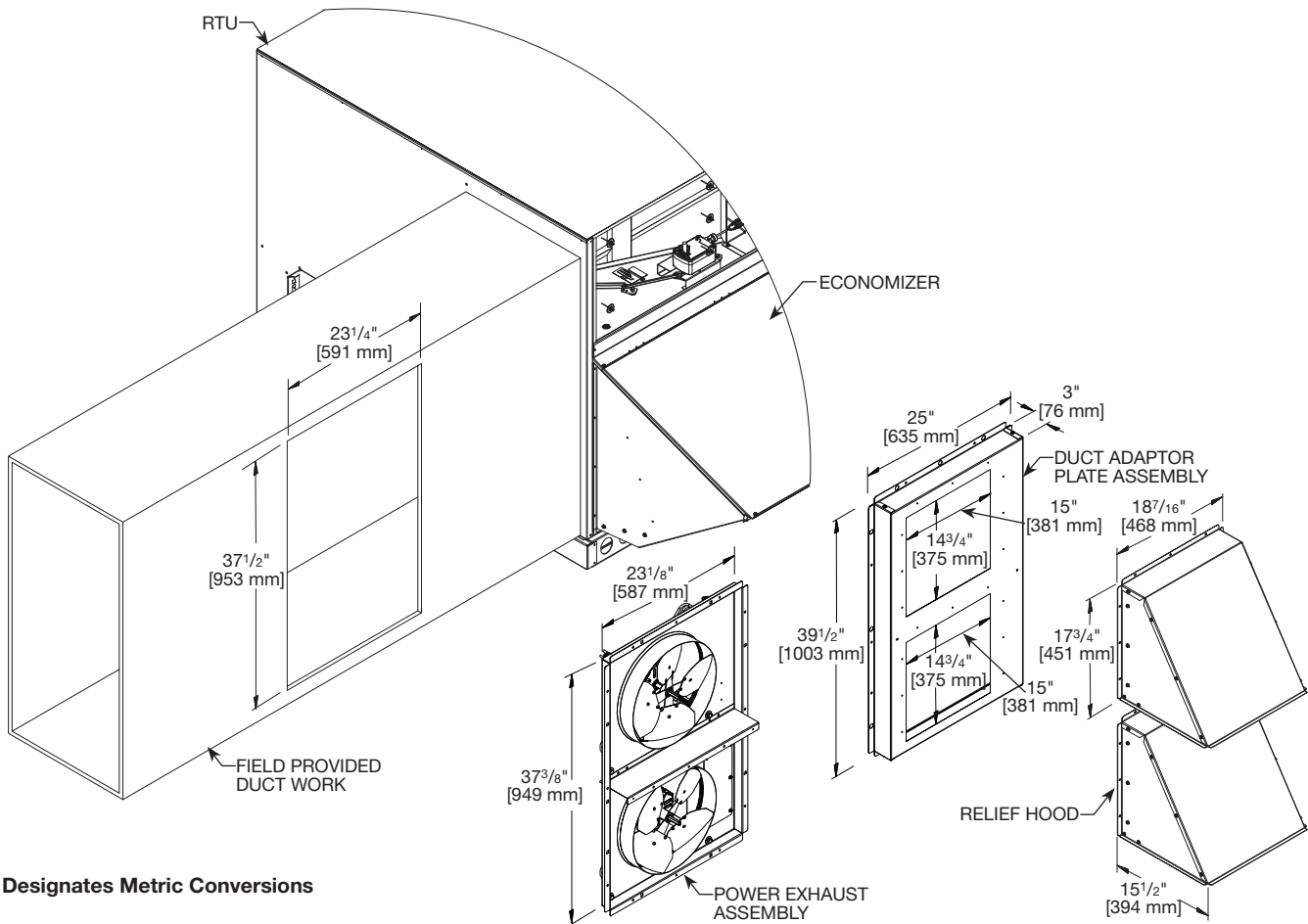

[] Designates Metric Conversions

MODEL NO.	VOLT	PHASE	MOTOR				UNIT				@ 0.1 CFM
			HP	RPM	LRA	QTY.	CIR. QTY.	FLA	MCA	FUSE SIZE	
RXXR-RDF03C	208/230	1	1/2	1625	5.86	1	1	2.70	3.38	6	2013
RXXR-RDF03D	460				3.33			1.34	1.68	3	

ROOFCURBS (Full Perimeter)

- Ruud's roofcurb design can be utilized on all 7.5-10 ton [26.4-35.1 kW] RHPD
- Two available heights (14" [356 mm] and 24" [610 mm]) for ALL models
- Quick assembly corners for simple and fast assembly
- Opening provided in bottom pan to match the "Thru the Curb" electrical connection opening provided on the unit base pan
- 1" [25 mm] x 4" [102 mm] Nailers provided
- Insulating panels not required because of insulated outdoor base pan
- Sealing gasket (40' [12.2 m]) provided with Roofcurb
- Packaged for easy field assembly

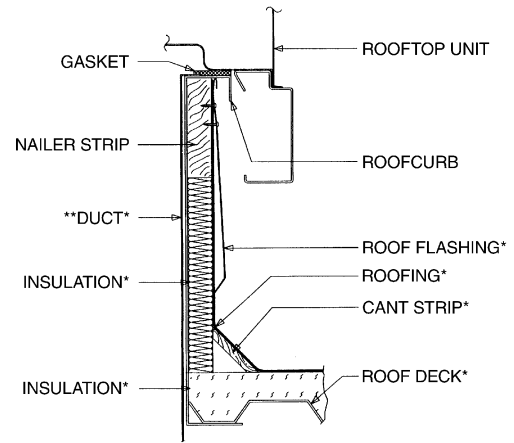

*BY CONTRACTOR

**FOR INSTALLATION OF DUCT AS SHOWN, USE RECOMMENDED DUCT SIZES FROM ROOFCURB INSTALLATION INSTRUCTIONS. FOR DUCT FLANGE ATTACHMENT TO UNIT, SEE UNIT INSTALLATION INSTRUCTIONS FOR RECOMMENDED DUCT SIZES.

Illustration
ST-A0743-02

View	Roofcurb Model	Height of Curb
A	RXKG-DDD14	14" [356 mm]
A	RXKG-DDD24	24" [610 mm]

ROOFCURB INSTALLATION

VIEW A

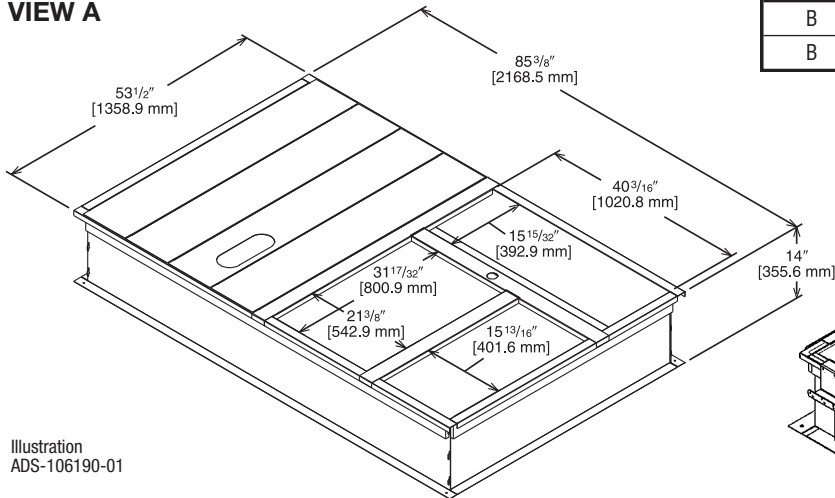
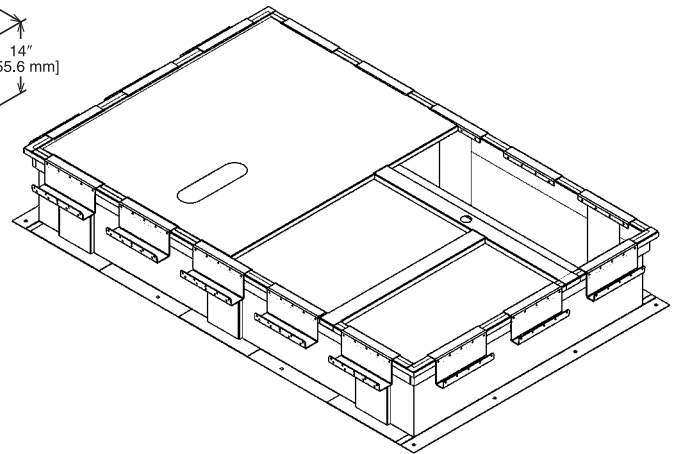

Illustration
ADS-106190-01

View	Roofcurb Model	Dimensions
B	RXKG-SD14	14" [356 mm]
B	RXKG-SD24	24" [610 mm]

WELDED ROOFCURB VIEW B



- **State of Florida Approved:** Approval Number FL 26981.1 for Technical Evaluation Report TER-20-28788 certifies the HVAC Unit and mounting methods for high wind resistance are compliant per Florida Building Code.
- **OSHPD Approved:** State of California Product Approval Number OSP-06660-TEMP00 for Technical Evaluation Report 1700876-CR-001-RO certifies the HVAC Unit and MicroMetl Welded Roof Curb is earthquake resistance compliant and approved for use per International Code Council – Evaluation Service AC156, IBC, AND CBC building code standards.

[] Designates Metric Conversions

ROOFCURB ADAPTERS

RXRX-DDCAE

Illustration
ADS-106176-01
SHEET 2

APPROXIMATE STATIC PRESSURE DROP

@2,000 = 0.06" w.g.
@3,000 = 0.12" w.g.
@4,000 = 0.22" w.g.
@5,000 = 0.36" w.g.

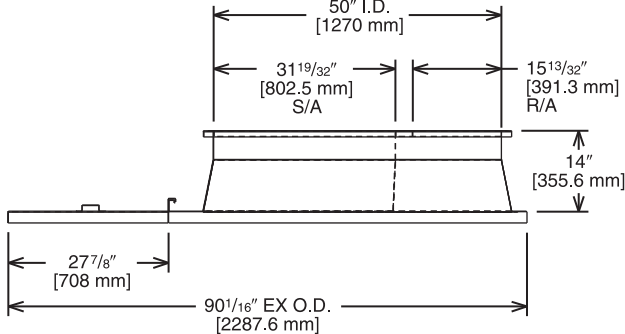
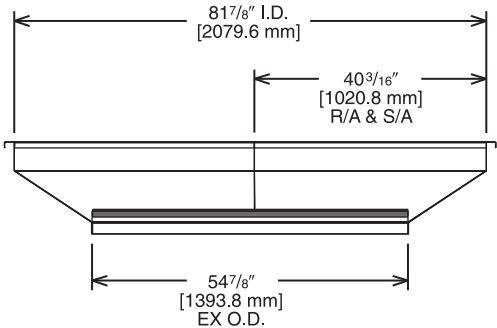
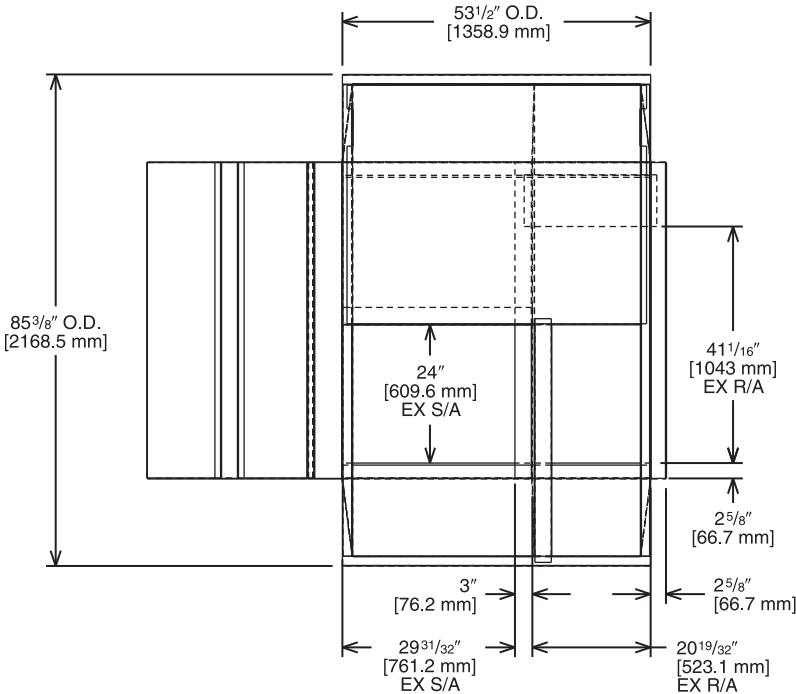

TOP VIEW

Illustration
ADS-106176-01
SHEET 1

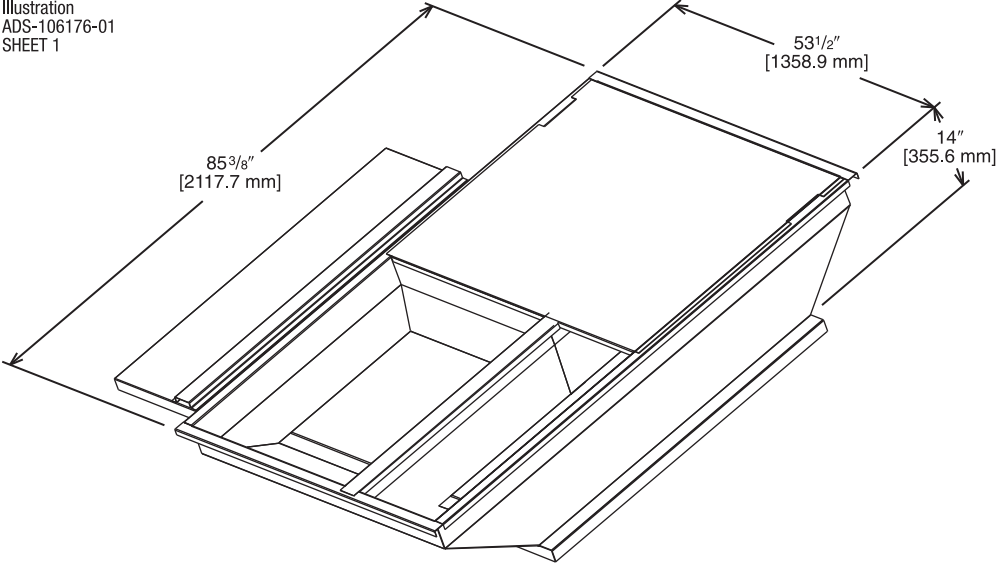

[] Designates Metric Conversions

GUIDE SPECIFICATIONS – RHPDYB – 090-120

You may copy this document directly into your building specification. This specification is written to comply with the 2016 version of the “master format” as published by the Construction Specification Institute. www.csinet.org.

ELECTRIC HEAT PUMP PACKAGED ROOFTOP

HVAC Guide Specifications

Size Range: 7.5 to 10 Nominal Tons

- 1.00 General:
 - A. Outdoor, rooftop mounted, electrically controlled, heating and cooling unit utilizing a(n) hermetic scroll compressor(s) for cooling duty and heat pump for heating duty.
 - B. Factory assembled, single-piece heating and cooling rooftop unit. Contained within the unit enclosure shall be all factory wiring, piping, controls, and special features required prior to field start-up.
 - C. Unit shall use environmentally safe, R-454B refrigerant.
 - D. Unit shall be installed in accordance with the manufacturer’s instructions.
 - E. Unit must be selected and installed in compliance with local, state, and federal codes.
 - F. Model and serial data shall be printed inside the control box.
- 1.01 Quality Assurance:
 - A. Unit meets ASHRAE 90.1 2022 minimum efficiency requirements.
 - B. Unit shall be rated in accordance with AHRI Standards 340/360.
 - C. Unit shall be designed to conform to ASHRAE 15.
 - D. Unit shall be UL-tested and certified in accordance with Standards and UL-listed and certified under Canadian standards as a total package for safety requirements.
 - E. Insulation and adhesive shall meet NFPA 90A requirements for flame spread and smoke generation.
 - F. Unit casing shall be capable of withstanding 1000-hour salt spray exposure per ASTM B117 (scribed specimen).
 - G. Roof curb shall be designed to conform to NRCA Standards.
 - H. Unit shall be subjected to a completely automated run test on the assembly line. The data for each unit will be stored at the factory, and must be available upon request.
 - I. Unit shall be designed in accordance with UL Standard 60335-2-40 4th Edition. including tested to withstand rain.
 - J. Unit shall be constructed to prevent intrusion of snow and tested to prevent snow intrusion into the control box up to 40 mph.
- 1.02 Manufacturer Qualifications
 - A. Unit shall be designed in accordance with ISO 9001:2015, and shall be manufactured in a facility registered by ISO 9001:2015.
- 1.03 Installer Qualifications
 - A. The installer shall be trained to install and service equipment with A2L refrigerants.
- 1.04 Delivery, Storage, and Handling:
 - A. Unit shall be stored and handled per manufacturer’s recommendations.
 - B. Unit lifted by crane requires either shipping top panel or spreader bars.
 - C. Unit shall only be stored or positioned in the upright position.
- 1.05 Unit Cabinet:
 - A. Unit cabinet shall be constructed of galvanized steel.
 - B. Unit cabinet exterior paint shall be pre-painted steel.
 - C. The sheet-metal cabinet shall be constructed of 18-gauge material for structural components with an underlying coat of G90.
 - D. Evaporator fan compartment interior cabinet insulation shall conform to AHRI Standards 210 or 360 minimum exterior sweat criteria. Interior surfaces shall be insulated with a minimum 1/2-in. thick, 1.6 lbs density, flexible fiberglass insulation, foil faced on the air side. Aluminum foil-faced fiberglass insulation shall be used in the gas heat compartment.
 - E. Shall utilize uniform screw sizing.
 - F. Base of unit shall have a location for thru-the-base gas and electrical connections standard.
 - G. Base Rail:
 - i. Unit shall have base rails on a minimum of 4 sides.
 - ii. Holes shall be provided in the base rails for rigging shackles to facilitate maneuvering and overhead rigging.
 - iii. Holes shall be provided in the base rail for moving the rooftop for fork truck.
 - iv. Base rail shall be a minimum of 14 gauge thickness.

- H. Condensate pan and connections:
 - i. Shall be a sloped condensate drain pan made of a non-corrosive material and be removable for cleaning.
 - ii. Shall comply with ASHRAE Standard 62.
 - iii. Shall use a 3/4" NPT drain connection, possible either through the bottom or side of the drain pan. Connection shall be made per manufacturer's recommendations.
 - iv. Shall be able to be easily removed.
 - v. Shall be separate from the coil.
- I. Standard factory-installed condensate overflow sensor.
- J. Top panel
 - i. Shall be a single piece top panel over indoor section.
- K. Electrical Connections
 - i. All unit power wiring shall enter unit cabinet via a single, factory-prepared, continuous raised flange opening in the
 - ii. Thru-the-base capability
 - a. Standard unit shall have a thru-the-base electrical location(s) using a raised, continuous raised flange opening in the basepan.
 - b. No basepan penetration, other than those authorized by the manufacturer, is permitted.
- L. Component access panels (standard)
 - i. Cabinet panels shall be easily opened for servicing.
 - ii. Stainless steel metal hinges are standard on all doors
 - iii. Panels covering control box, indoor fan, indoor fan motor, and electric or gas heater components (where applicable), shall have 1/4 turn latches.
- 1.06 Operating Characteristics:
 - A. Unit shall be capable of starting and running at 115°F (46°C) ambient outdoor temperature, meeting maximum load criteria of AHRI Standard 340/360 at ± 10% voltage.
 - B. Compressor with standard controls shall be capable of operation down to 40°F (4°C), ambient outdoor temperatures. Low ambient accessory kit is necessary if mechanically cooling at ambient temperatures to 40°F (4°C).
 - C. Unit shall discharge supply air vertically or horizontally as shown on contract drawings.
 - D. Unit shall be factory configured for vertical supply & return configurations.
 - E. Unit shall be field convertible from vertical to horizontal configuration.
 - F. Unit shall be capable of mixed operation: vertical supply with horizontal return or horizontal supply with vertical return.
- 1.07 Electrical Requirements
 - A. Main power supply voltage, phase, and frequency must match those required by the manufacturer.
- 1.08 Evaporator fan compartment:
 - A. Interior cabinet surfaces shall be insulated with a minimum 1/2-in. thick, minimum 1.6 LB density, flexible fiberglass insulation bonded with foil face on the air side.
 - B. Insulation and adhesive shall meet NFPA 90A requirements for flame spread and smoke generation.
 - C. Insulation shall also be mechanically fastened with welded pin and retainer washer.
- 1.09 Thermostats
 - A. Thermostat must:
 - i. Energize both "W" and "G" when calling for heat.
 - ii. Have capability to energize 1 stage of cooling, and at least 1 stage of heating.
 - iii. Include capability for occupancy scheduling.
- 1.10 Electronic Control System for HVAC:
 - A. Shall be complete with self-contained low-voltage control circuit protected by a fuse on the 24-V transformer side (090-150 units have a resettable circuit breaker).
 - B. Shall utilize color-coded wiring.
 - C. Shall include a central control terminal board to conveniently and safely provide connection points for vital control functions such as: smoke detectors, phase monitor, economizer, thermostat, DDC control options, loss of charge, freeze sensor, high-pressure switches.
 - D. Unit shall include a minimum of one 10-pin screw terminal connection board for connection of control wiring.
 - E. Unit control board shall be provided with 7 segment readout via LCD display for status and diagnostics.

1.10.01 Safeties:

- A. Compressor over-temperature, over current.
- B. Standard Low-pressure switch:
 - i. Units shall have low-pressure, loss of charge automatic reset device that will shut off compressor when tripped.
 - ii. Low-pressure control:
 - a. Provides active protection in both heating and cooling modes at all outdoor ambient temperatures. The low-pressure control is an automatic reset type and opens at approximately 15 psig and closes at approximately 40 psig. Operation is slightly different between cooling and heating modes.
- C. Standard High-pressure switch:
 - i. Unit shall be equipped with high-pressure switch device that will shut off compressor when tripped.
 - ii. High-pressure control:
 - iii. The high-pressure control is an automatic reset type and opens at approximately 610 psig and closes at approximately 420 psig. The compressor and fan motor will stop when the high-pressure control opens and will start again if the high side pressure drops to approximately 420 psig where the automatic reset high-pressure control resets. If the high-pressure control opens 3 times within a particular call for heating or cooling operation, the defrost control will lock out compressor and outdoor fan operation.
- D. Automatic reset, motor thermal overload protector.
- E. The unit must be permanently grounded.
- F. Components are not compatible between different refrigerants. Do not use R-410A service equipment or components on R-454B equipment. System or part failure could occur.
- G. Heating section shall be provided with the following minimum protections:
 - i. High-temperature limit switches.
 - ii. Induced draft motor pressure switch.

1.11 Standard Filter Section:

- A. Filters shall consist of factory-installed, low velocity, throwaway 2-in. thick fiberglass filters of commercially available sizes.
- B. Unit will accept both 2-in. and 4-in. filters.
- C. Filter face velocity shall not exceed 365 fpm at nominal airflows.
- D. Filters shall be accessible through an access panel with “no-tool” removal as described in the unit cabinet section of the specification.
- E. Filters access is specified in the unit cabinet section of this specification.
- F. Filters shall be held in place by metal rods, facilitating easy removal and installation.

1.12 Coils

- A. Standard Aluminum/MicroChannel Coils:
 - i. Standard evaporator and condenser coils shall be aluminum.
 - ii. Evaporator and condenser coils shall be leak tested to 150 psig, pressure tested to 400 psig, and qualified to burst test at 2,200 psi.

1.13 Refrigerant Components:

- A. Refrigerant circuit shall include the following control, safety, and maintenance features:
 - i. TXV metering system shall prevent mal-distribution of two-phase refrigerant.
 - ii. Refrigerant filter drier.
 - iii. Service gauge connections on suction and discharge lines.
 - iv. External pressure gauge ports access shall be located in front exterior of cabinet.
 - v. External gauge ports shall be lockable.
- B. Compressors:
 - i. Unit shall use one fully hermetic, 2-stage scroll compressor for each independent refrigeration circuit.
 - ii. Compressor motors shall be cooled by refrigerant gas passing through motor windings.
 - iii. Compressors shall be internally protected from high discharge temperature conditions.
 - iv. Compressors shall be protected from an over-temperature and over-ampereage conditions by an internal, motor overload device.
 - v. Compressor shall be factory mounted on rubber grommets.
 - vi. Compressor motors shall have internal line break thermal and current overload protection.
 - vii. Crankcase heaters shall not be required for normal operating range.
 - viii. Compressor shall have molded electrical plug.

- 1.14 Evaporator Fan and Motor:
- A. Evaporator Fan Motor:
 - i. Shall have permanently lubricated bearings.
 - ii. Shall have inherent automatic-reset thermal overload protection.
 - iii. Shall have a maximum continuous bhp rating for continuous duty operation; no safety factors above that rating shall be required.
 - B. Direct Drive Evaporator Fan:
 - i. Belt drive shall include an adjustable-pitch motor pulley.
 - ii. Shall use sealed, permanently lubricated ball-bearing type.
 - iii. Blower fan shall be double-inlet type with forward-curved blades.
 - iv. Shall be constructed from steel with a corrosion resistant finish and dynamically balanced.
 - C. Blower Assembly:
 - i. Entire assembly shall be able to slide out completely.
 - ii. Shall be able to slide-out without the removal of the roof and condenser fan motors.
- 1.15 Condenser Fans and Motors:
- A. Condenser Fan Motors:
 - i. Shall be a totally enclosed motor.
 - ii. Shall use permanently lubricated bearings.
 - iii. Shall have inherent thermal overload protection with an automatic reset feature.
 - iv. Shall use a shaft-down design. Shaft-up designs including those with “rain-slinger devices” shall not be allowed.
 - B. Condenser Fans:
 - i. Shall be a direct-driven propeller type fan.
 - ii. Shall have blades riveted to corrosion-resistant steel spiders and shall be dynamically balanced.
- 1.16 RTU-C Controller:
- A. Shall be ASHRAE 62-2001 compliant.
 - B. Shall accept 18-32VAC input power.
 - C. Shall have an operating temperature range from -40°F (-40°C) to 158°F (70°C), 10%–95% RH (non-condensing).
 - D. Controller shall accept the following inputs: space temperature, setpoint adjustment, outdoor air temperature, indoor air quality, outdoor air enthalpy, fire shutdown, return air enthalpy, fan status, remote time clock/door switch.
 - E. Shall accept a CO₂ sensor in the conditioned space, and be Demand Control Ventilation (DCV) ready.
 - F. Shall provide the following outputs: Economizer, fan, cooling stage 1, cooling stage 2, heat stage 1, heat stage 2, exhaust, occupied.
 - G. Unit shall provide surge protection for the controller through a circuit breaker.
 - H. Shall have a field-installed communication card allowing the unit to be able to communicate at a Baud rate of 19.2K or faster.
 - I. Shall have an LED display independently showing the status of activity on the communication bus, and processor operation.
 - J. Optional field-installed BACnet plug-in communication card which includes an EIA-485 protocol communication port, or an optional field-installed LonWorks plug-in communications card.
 - K. Software upgrades will be accomplished by local download. Software upgrades through chip replacements are not allowed.
 - L. Shall be shock resistant in all planes to 5G peak, 11ms during operation, and 100G peak, 11ms during storage.
 - M. Shall be vibration resistant in all planes to 1.5G @ 20-300 Hz.
 - N. Shall support a bus length of 4000 ft max, 60 devices per 1000 ft section, and 1 RS-485 repeater per 1000 ft sections.
- 1.17 Open Protocol, Direct Digital Controller:
- A. Shall be ASHRAE 62-2001 compliant.
 - B. Shall accept 18-30VAC, 50-60Hz, and consumer 15VA or less power.
 - C. Shall have an operating temperature range from -40°F (-40°C) to 130°F (54°C), 10% - 90% RH (non-condensing).
 - D. Shall have either a field-installed BACnet plug-in communication card which includes an EIA-485 protocol communication port, or a field-installed LonWorks plug-in communications card.
 - E. The BACnet plug in communication card shall include built-in protocol for BACnet (MS/TP and PTP modes).
 - F. The LonWorks plug in communication card shall include the Echelon processor required for all Lon applications.
 - G. Shall allow access of up to 62 network variables (SNVT). Shall be compatible with all open controllers.
 - H. Baud rate Controller shall be selectable through the EIA-485 protocol communication port.
 - I. Shall have an LED display independently showing the status of serial communication, running, errors, power, all digital outputs, and all analog inputs.

- J. Shall accept the following inputs: space temperature, setpoint adjustment, outdoor air temperature, indoor air quality, outdoor air enthalpy, compressor lock-out, fire shutdown, enthalpy switch, and fan status/filter status/humidity/remote occupancy.
 - K. Shall provide the following outputs: economizer, fan, cooling stage 1, cooling stage 2, heat stage 1, heat stage 2, exhaust.
 - L. Software upgrades will be accomplished by either local or remote download. No software upgrades through chip replacements are allowed.
 - M. Shall be natively equipped with Modbus communication protocol.
- 1.18 Adjustable Frequency Drive:
- A. Unit shall be supplied with an electronic variable frequency drive for the supply air fan.
 - B. Drive shall be factory-installed in an enclosed cabinet.
 - C. Drive shall meet UL Standard 60335-2-40 4th Edition.
 - D. The completed unit assembly shall be UL listed.
 - E. Drives are to be accessible through a tooled access hinged door assembly.
 - F. The unit manufacturer shall install all power and control wiring.
 - G. The supply air fan drive output shall be controlled by the factory-installed main unit control system and drive status and operating speed shall be monitored and displayed at the main unit control panel.
 - H. Drive shall be programmed and factory run tested in the unit.
- 1.19 Special Features:
- A. Integrated Economizers:
 - i. Integrated, parallel modulating blade design type capable of simultaneous economizer and compressor operation.
 - ii. Independent modules for vertical or horizontal return configurations shall be available. Vertical return modules shall be available as a factory-installed option.
 - iii. Damper blades shall be galvanized steel. Plastic or composite blades on intake or return shall not be acceptable.
 - iv. Shall include all hardware and controls to provide free cooling with outdoor air when temperature and/or humidity are below setpoints.
 - v. Shall be equipped with dampers for both the outdoor ventilation air and the return air for positive air stream control.
 - vi. Shall be equipped with low-leakage dampers, not to exceed 2% leakage at 1 in. wg pressure differential.
 - vii. Shall be capable of introducing up to 100% outdoor air.
 - viii. Shall be equipped with a barometric relief damper capable of relieving up to 100% return air.
 - ix. Shall be designed to close damper(s) during loss-of-power situations with spring return built into motor.
 - x. Enthalpy sensor shall be provided as standard. Outdoor air sensor set point shall be adjustable and shall range from 40 to 100°F / 4 to 38°C. Additional sensor options shall be available as accessories.
 - xi. The economizer controller shall also provide control of an accessory power exhaust unit function. Factory set at 70%, with a range of 0% to 100%.
 - xii. The economizer shall maintain minimum airflow into the building during occupied period and provide design ventilation rate for full occupancy. A remote potentiometer may be used to override the damper set point.
 - xiii. Dampers shall be completely closed when the unit is in the unoccupied mode.
 - xiv. Economizer controller shall accept a 2-10Vdc CO2 sensor input for IAQ/DCV control. In this mode, dampers shall modulate the outdoor-air damper to provide ventilation based on the sensor input.
 - xv. Economizer controller shall provide indications when in free cooling mode, in the DCV mode, or the exhaust fan contact is closed.
 - xvi. Economizer wire harness will have provision for smoke detector available in supply and return options.
 - xvii. Shall provide fault detection and diagnostics (FDD) system in accordance with local code. Faults shall be communicated out on an alarm signal.
 - B. Two-Position Motorized Damper
 - i. Damper shall be a Two-Position Motorized Damper. Damper travel shall be from the full closed position to the field adjustable %-open setpoint.
 - ii. Damper shall include adjustable damper travel from 25% to 100% (full open).
 - iii. Damper shall include single or dual blade, gear driven dampers and actuator motor.
 - iv. Actuator shall be direct coupled to damper gear. No linkage arms or control rods shall be acceptable.
 - v. Damper will admit up to 100% outdoor air for applicable rooftop units.
 - vi. Damper shall close upon indoor (evaporator) fan shutoff and/or loss of power.
 - vii. The damper actuator shall plug into the rooftop unit's wiring harness plug. No hard wiring shall be required.
 - viii. Outside air hood shall include aluminum water entrainment filter

- C. Manual damper:
 - i. Manual damper package shall consist of damper, air inlet screen, and rain hood which can be preset to admit up to 50% outdoor air for year-round ventilation.
- D. Condenser Coil Hail Guard Assembly
 - i. Shall protect against damage from hail.
 - ii. Shall be louvered style.
- E. Unit-Mounted, Non-Fused Disconnect Switch:
 - i. Switch shall be factory-installed, internally mounted.
 - ii. National Electric Code (NEC) and UL approved non-fused switch shall provide unit power shutoff.
 - iii. Shall be accessible from outside the unit.
 - iv. Shall provide local shutdown and lockout capability.
- F. Convenience Outlet:
 - i. Non-Powered convenience outlet.
 - ii. Outlet shall be powered from a separate 115-120v power source.
 - iii. A transformer shall not be included.
 - iv. Outlet shall be field-installed and internally mounted with easily accessible 115-v female receptacle.
 - v. Outlet shall include 15 amp GFI receptacle with independent fuse protection.
 - vi. Outlet shall be accessible from outside the unit.
- G. Propeller Power Exhaust:
 - i. Power exhaust shall be used in conjunction with an integrated economizer.
 - ii. Independent modules for vertical or horizontal return configurations shall be available.
 - iii. Horizontal power exhaust shall be mounted in return ductwork.
 - iv. Power exhaust shall be controlled by economizer controller operation. Exhaust fans shall be energized when dampers
 - v. Capable of adjustable but constant volume.
- H. Roof Curbs (Vertical):
 - i. Formed galvanized steel with wood nailer strip and shall be capable of supporting entire unit weight.
 - ii. Permits installation and securing of ductwork to curb prior to mounting unit on the curb.
 - iii. Return Air Enthalpy Sensor:
 - iv. The return air enthalpy sensor shall be used in conjunction with an outdoor air enthalpy sensor to provide differential enthalpy control.
- I. Return Air Enthalpy Sensor:
 - i. The return air enthalpy sensor shall be used in conjunction with an outdoor air enthalpy sensor to provide differential enthalpy control.
- J. Indoor Air Quality (CO2) Sensor:
 - i. Shall be able to provide demand ventilation indoor air quality (IAQ) control.
 - ii. The IAQ sensor shall be available in duct mount, wall mount, or wall mount with LED display. The set point shall have adjustment capability.
- K. Smoke detectors:
 - i. Shall be a Four-Wire Controller and Detector.
 - ii. Shall be environmental compensated with differential sensing for reliable, stable, and drift-free sensitivity.
 - iii. Shall use magnet-activated test/reset sensor switches.
 - iv. Shall have tool-less connection terminal access.
 - v. Shall have a recessed momentary switch for testing and resetting the detector.
 - vi. Controller shall include:
 - a. One set of normally open alarm initiation contacts for connection to an initiating device circuit on a fire alarm control panel
 - b. Two Form-C auxiliary alarm relays for interface with rooftop unit or other equipment
 - c. One Form-C supervision (trouble) relay to control the operation of the Trouble LED on a remote test/reset station
 - d. Capable of direct connection to two individual detector modules.
 - e. Can be wired to up to 14 other duct smoke detectors for multiple fan shutdown applications.

- L. Barometric relief
 - i. Shall include damper, seals, hardware, and hoods to relieve excess building pressure.
 - ii. Damper shall gravity-close upon shutdown.
- M. Time Guard
 - i. Shall prevent compressor short cycling by providing a 5-minute delay (± 2 minutes) before restarting a compressor after shutdown for any reason.
 - ii. One device shall be required per compressor.
- N. Standard Factory-Installed Overflow Switch
 - i. Switch shall monitor the condensate level in drain pan and stops compression operation when overflow conditions occur
- O. Access Panels
 - i. Hinges with $\frac{1}{4}$ turn fasteners shall be permanently attached.
 - ii. Hinges shall be powder coated and made from stainless steel.
- P. Head Pressure Control Package
 - i. Controller shall control coil head pressure by condenser-fan cycling.
- Q. Fan/Filter Status Switch:
 - i. Switch shall provide status of indoor evaporator fan (ON/OFF) or filter (CLEAN/DIRTY).
 - ii. Status shall be displayed either over communication bus (when used with direct digital controls) or through the controller LCD display inside the unit control box.
- R. Refrigerant Leak Detection System:
 - i. Shall be standard and factory-installed in every unit.
 - ii. Shall trigger a fault code to the unit controller and initiate mitigation procedures.



GENERAL TERMS OF LIMITED WARRANTY*

Ruud will furnish a replacement for any part of this product which fails in normal use and service within the applicable periods stated, in accordance with the terms of the limited warranty.

*For complete details of the Limited and Conditional Warranties, including applicable terms and conditions, contact your local contractor or the Manufacturer for a copy of the product warranty certificate.

Compressor

Commercial ApplicationsFive (5) Years

Parts

Commercial ApplicationsOne (1) Year

Before proceeding with installation, refer to installation instructions packaged with each model, as well as complying with all Federal, State, Provincial, and Local codes, regulations, and practices.

Trademarks are property of their respective owners.

In keeping with its policy of continuous progress and product improvement, Ruud reserves the right to make changes without notice.

5600 Old Greenwood Road
Fort Smith, Arkansas 72908 • www.ruud.com

125 Edgeware Road, Unit 1
Brampton, Ontario • L6Y 0P5

RELY ON RUUD.™