



The new degree of comfort.™

# SUBMITTAL COVER SHEET

PROJECT NAME \_\_\_\_\_

LOCATION \_\_\_\_\_

ARCHITECT \_\_\_\_\_

ENGINEER \_\_\_\_\_

CONTRACTOR \_\_\_\_\_

SUBMITTED BY \_\_\_\_\_ DATE \_\_\_\_\_

## UNIT SUMMARY

Quantity						
Unit Designation						
Model No.						
Total Cooling						
Sensible Cooling						
Air Ent. Evaporator						
Air Lvg. Evaporator						
Heating Input						
Heating Output						
CFM/ESP						
EER/SEER						
Electrical						
Minimum Ampacity						
Min.-Max. Breaker						
Net Unit Weight						
Accessory						
Catalog Form Number						

**ACCESSORIES:**

**NOTES:**







## RA14 Series

Efficiencies up to 15.5 SEER/13 EER

Nominal Sizes 1<sup>1</sup>/<sub>2</sub> to 5 Ton [5.28 to 17.6 kW]

Cooling Capacities 17.3 to 60.5 kBTU

[5.7 to 17.7 kW]



*"Proper sizing and installation of equipment is critical to achieve optimal performance. Split system air conditioners and heat pumps must be matched with appropriate coil components to meet Energy Star. Ask your Contractor for details or visit [www.energystar.gov](http://www.energystar.gov)."*

- Composite base pan – dampens sound, captures louver panels, eliminates corrosion and reduces number of fasteners needed
- Powder coat paint system – for a long lasting professional finish
- Scroll compressor – uses 70% fewer moving parts for higher efficiency and increased reliability
- Modern cabinet aesthetics – increased curb appeal with visually appealing design
- Curved louver panels – provide ultimate coil protection, enhance cabinet strength, and increased cabinet rigidity
- Optimized fan orifice – optimizes airflow and reduces unit sound
- Rust resistant screws – confirmed through 1500-hour salt spray testing
- PlusOne™ **Expanded Valve Space** – 3"-4"-5" service valve space – provides a minimum working area of 27-square inches for easier access
- PlusOne™ **Triple Service Access** – 15" wide, industry leading corner service access – makes repairs easier and faster. The two fastener removable corner allows optimal access to internal unit components. Individual louver panels come out once fastener is removed, for faster coil cleaning and easier cabinet reassembly
- Diagnostic service window with two-fastener opening – provides access to the high and low pressure.
- External gauge port access – allows easy connection of "low-loss" gauge ports
- Single-row condenser coil – makes unit lighter and allows thorough coil cleaning to maintain "out of the box" performance
- 35% fewer cabinet fasteners and fastener-free base – allow for faster access to internal components and hassle-free panel removal
- Service trays – hold fasteners or caps during service calls
- QR code – provides technical information on demand for faster service calls
- Fan motor harness with extra long wires allows unit top to be removed without disconnecting fan wire.

# Unit Dimensions

MODEL NO.	OPERATING						SHIPPING					
	H (Height)		L (Length)		W (Width)		H (Height)		L (Length)		W (Width)	
	INCHES	mm	INCHES	mm	INCHES	mm	INCHES	mm	INCHES	mm	INCHES	mm
RA1418A	25	635	29.75	755	29.75	755	26.75	679	32.38	822	32.38	822
RA1424A	25	635	29.75	755	29.75	755	26.75	679	32.38	822	32.38	822
RA1430A	27	685	29.75	755	29.75	755	28.75	730	32.38	822	32.38	822
RA1436A	27	685	33.75	857	33.75	857	28.75	730	36.38	924	36.38	924
RA1442B	31	787	33.75	857	33.75	857	32.75	832	36.38	924	36.38	924
RA1448A	31	787	35.75	908	35.75	908	32.75	832	38.38	975	38.38	975
RA1460A	35	889	35.75	908	35.75	908	36.75	933	38.38	975	38.38	975

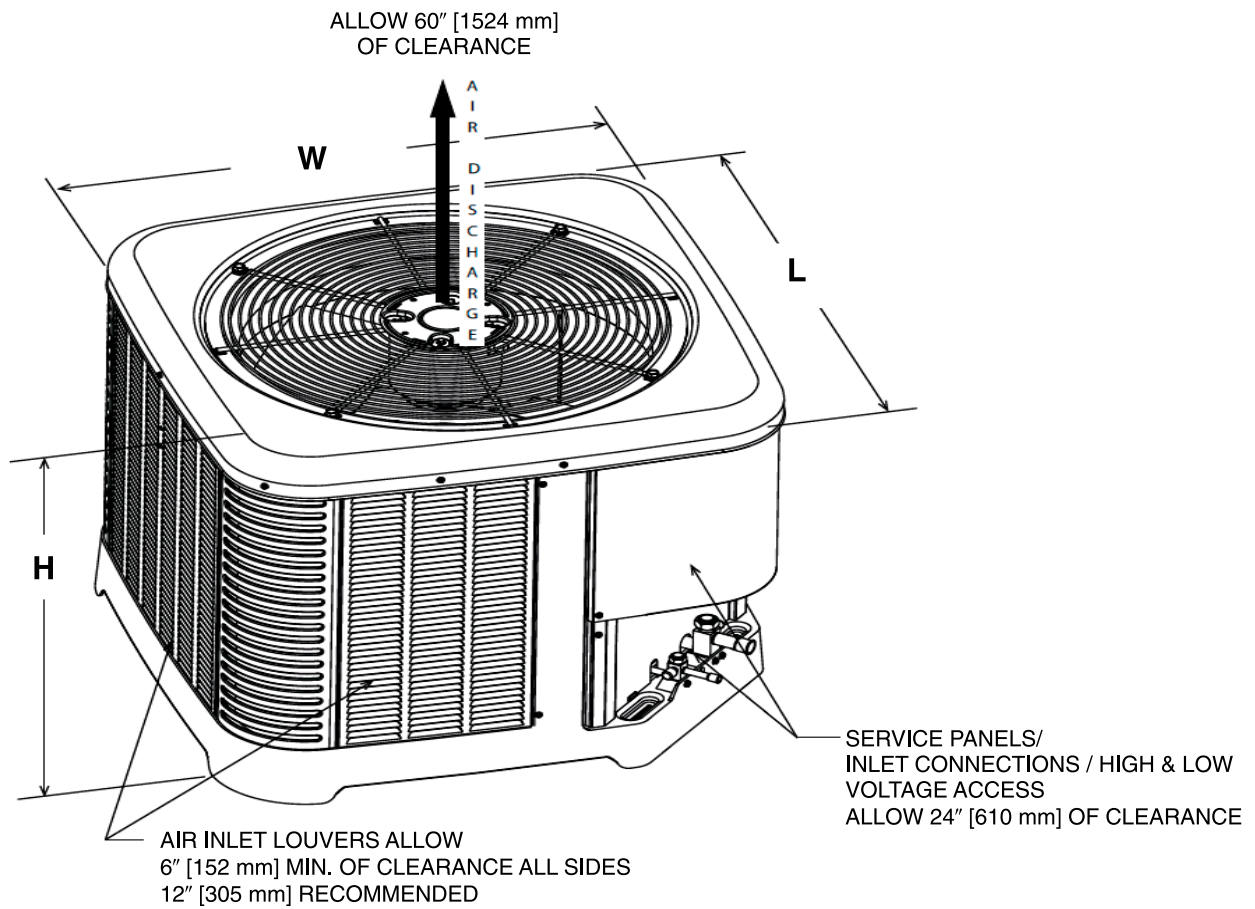

[ ] Designates Metric Conversions

ST-A1226-02-00