



The new degree of comfort.®

Rheem® Professional Classic® RTEX Tankless Electric Water Heaters

Provide Endless Hot Water in a Durable, Space-Saving Design

RTEX - 8, RTEX - 11, RTEX - 13 are designed for one or two applications and are installed at the point-of-use. The durable, compact design allows installation in tight spaces. Perfect for a low flow faucet or bathroom faucet. In warmer climates, these models can accommodate a shower. To select a unit that meets electrical and hot water gallons per minute (GPM) requirements, please use the sizing guide.

PERFORMANCE FEATURES

- **Saves Space** – up to 93% smaller than a standard electric water heater
- **Saves Energy** – zero standby heat loss when installed near the point-of-use
- **More Hot Water** – up to 4 times the hot water delivery of a standard electric tank (per hour)
- **High Efficiency** – UEF up to .96 and advanced self-modulating technology only consumes the power needed to satisfy hot water demand
- Copper immersion heating elements improve the thermal performance providing better temperature control and faster recovery of hot water
- Stainless steel heat exchanger transfers heat fast and resists corrosion
- Durable powder-coated shell with an engineered polymer backplate
- Brass ½ compression fittings (CF) located on the side for the inlet and outlet water connections provide strength and durability
- Designed to be mounted in an upright position with the inlet and outlet water connections on the side of the unit
- Venting is not required to operate, simplifying the installation process compared to a gas tankless water heater
- Digital thermostatic temperature controls in 1-degree increments ranging from 80°F - 140°F (26°C - 60°C)

WARRANTY

- Limited Warranty – 5 Years - Leaks, 1 Year - Parts
See Use and Care Manual for complete information.



These products meet a stringent set of our company's internally defined sustainability standards.



Tested and certified by the Water Quality Association against NSF/ANSI 372 for lead free compliance.

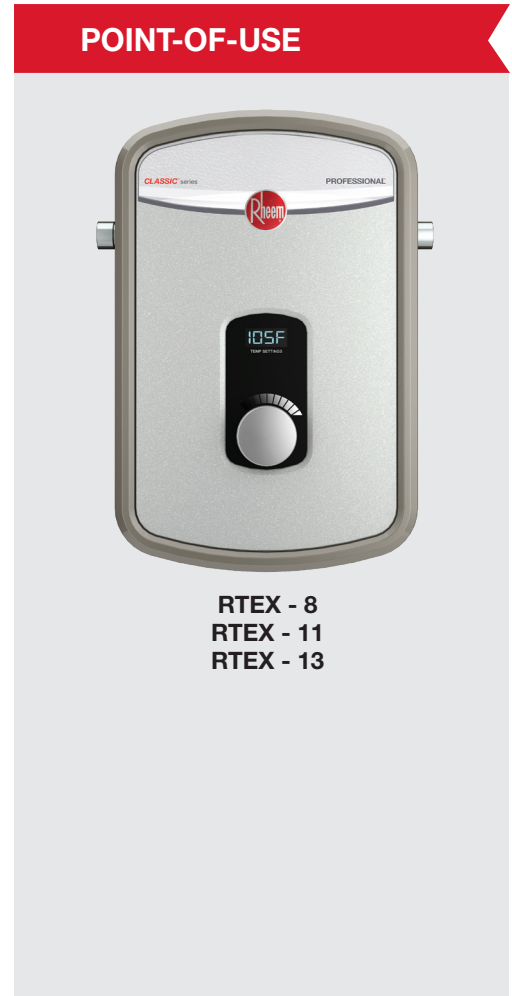

RTEX - 8
RTEX - 11
RTEX - 13

Tankless Electric Specifications and Minimum Requirements

DESCRIPTION	FEATURES					DIMENSIONS (SHOWN IN INCHES)							WATER CONN.	ELEMENT	SHIP WEIGHT (LBS.)	HEAT EXCHANGER	OPERATING PRESSURE	FLOW ACTIVATION RATE (GPM)
	MODEL NUMBER	POWER (kW)	VOLTAGE	TOTAL UNIT AMPERAGE (AMPS)	RECOM'D BREAKER SIZE	HOUSEHOLD ELECTRICAL SERVICE PANEL RECOM'D	PHASE	UNIFORM ENERGY FACTOR (UEF)	REQUIRED WIRE (75°C INSULATION)	HEIGHT	WIDTH	DEPTH						
RTEX - 8	8	240	33	1 x 40 A Double Pole	100 AMPS	1	0.96	8 AWG*	11.4	7.9	3.7	1/2" CF	1	4.75	Stainless Steel	Min: 25 PSI Max: 150 PSI	0.3 GPM	
RTEX - 11	11	240	46	1 x 50 A Double Pole	100 AMPS	1	0.92	6 AWG*	11.4	7.9	3.7	1/2" CF	1	6.5	Stainless Steel	Min: 25 PSI Max: 150 PSI	0.3 GPM	
RTEX - 13	13	240	54	1 x 60 A Double Pole	100 AMPS	1	0.92	6 AWG*	11.4	7.9	3.7	1/2" CF	1	6.5	Stainless Steel	Min: 25 PSI Max: 150 PSI	0.3 GPM	

NOTE: When converting from an electric tank to an electric tankless water heater, household electric service panel upgrades are often required. Please see the electric service panel recommendations above.

*AWG - American Wire Gauge





The new degree of comfort®



Residential Electric
Professional Classic
Tankless Water Heaters

RTEX - 8

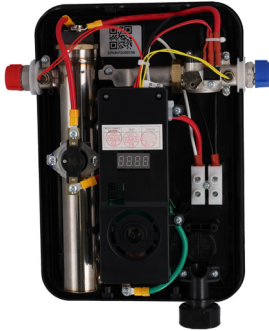

RTEX - 11, RTEX - 13

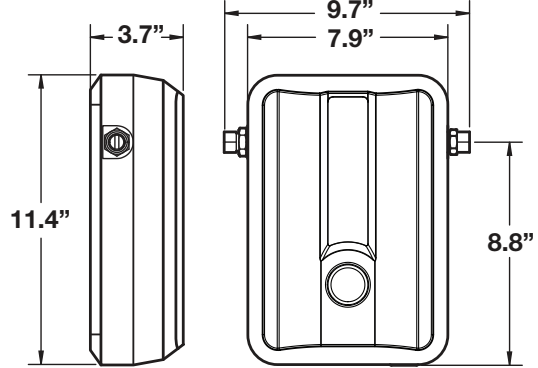
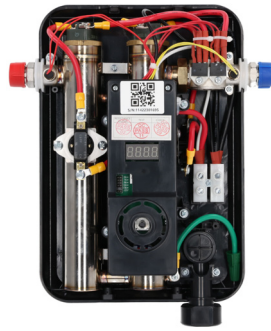

SIZING A TANKLESS ELECTRIC WATER HEATER

IMPORTANT – Verify that your home meets the electrical requirements. See specifications and minimum requirements. (front side)

- 1 Estimate your total household gallons per minute (GPM) needs by adding up the average flow rates by fixture (faucets, showers) that run at the same time.

Ex. 1 bathroom faucet and 1 low flow faucet running at the same time adds up to 1.5 GPM (1 + 0.5 = 1.5 GPM)

Average Flow Rates (GPM) by Fixture

Low Flow Faucet	0.5
Bathroom Faucet	1
Kitchen Faucet	1.5
Low Flow Shower	1.5
Shower	2

Flow rates may vary.

- 2 Locate your zone on the map.

U.S. Average Ground Water Temperature Zone Map

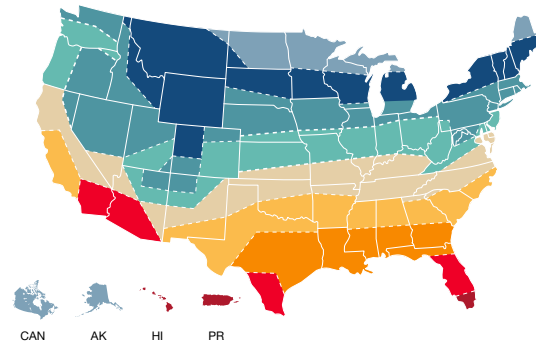

- 3 Select the model that can supply you with the estimated total household gallons per minute (Step 1) with the ground water temperature in your zone.

Flow Rate Capacity Table by Zone (Gallons Per Minute - GPM)

Model #	Zone 1 37°F/ 3°C	Zone 2 42°F/ 5°C	Zone 3 47°F/ 8°C	Zone 4 52°F/ 11°C	Zone 5 57°F/ 14°C	Zone 6 62°F/ 17°C	Zone 7 67°F/ 20°C	Zone 8 72°F/ 22°C	Zone 9 77°F/ 28°C
RTEX - 8	0.8	0.9	0.9	1.0	1.1	1.3	1.4	1.7	2.0
RTEX - 11	1.1	1.2	1.3	1.4	1.6	1.7	2.0	2.3	2.7
RTEX - 13	1.3	1.4	1.5	1.7	1.9	2.1	2.3	2.7	3.2

Flow rates are calculated to a set point of 105°F. Ground water temperature varies seasonally.

OPTIONAL – Flow Regulator Sizing Table by Zone (Gallons Per Minute – GPM)

The flow regulator fitting threads onto the outlet water connection and limits the outlet flow to the GPM specified in the table. Select the appropriate GPM insert for your model based on your zone. This is an optional part to ensure accurate temperature output.

Model #	kW	Connection Size	Part #	Zone 1	Zone 2/3	Zone 4/5	Zone 6/7	Zone 8/9
				37°F/ 3°C	42-47°F/ 5-8°C	52-57°F/ 11-14°C	62-67°F/ 17-20°C	72-77°F/ 22-28°C
RTEX - 8	8	½" NPT	IFR 1-2	–	–	1.0	1.0	1.5
RTEX - 11	11	½" NPT	IFR 1-2	1.0	1.0	1.0	1.5	2.0
RTEX - 13	13	½" NPT	IFR 1-2	1.0	1.0	1.5	2.0	2.0

NOTE: (–) indicates flow regulator insert is not recommended in this zone.

In keeping with its policy of continuous progress and product improvement, Rheem reserves the right to make changes without notice.

Rheem.com | 800.374.8806
Manufacturers National Service Department
400 Captain Neville Drive, Waterbury, CT 06705



INTEGRATED HOME COMFORT