



**Russell**<sup>TM</sup>  
By Rheem

## SUBMITTAL COVER SHEET

PROJECT NAME \_\_\_\_\_

LOCATION \_\_\_\_\_

ARCHITECT \_\_\_\_\_

ENGINEER \_\_\_\_\_

CONTRACTOR \_\_\_\_\_

SUBMITTED BY \_\_\_\_\_ DATE \_\_\_\_\_

### UNIT SUMMARY

Quantity						
Unit Designation						
Model No.						
Total Cooling						
Sensible Cooling						
Air Ent. Evaporator						
Air Lvg. Evaporator						
Heating Input						
Heating Output						
CFM/ESP						
EER/SEER						
Electrical						
Minimum Ampacity						
Min.-Max. Breaker						
Net Unit Weight						
Accessory						
Catalog Form Number						

**ACCESSORIES:**

**NOTES:**

# SH2T AIR HANDLERS

## 2 to 5 Nominal Ton [7.3 to 17.6 kW]

JOB NAME \_\_\_\_\_ LOCATION \_\_\_\_\_

CONTRACTOR \_\_\_\_\_ ORDER NO. \_\_\_\_\_

ENGINEER \_\_\_\_\_ SUBMITTED FOR  APPROVAL  RECORD

DATE \_\_\_\_\_ OUTDOOR UNIT MODEL NO. \_\_\_\_\_

MODEL NO. \_\_\_\_\_ INDOOR COIL MODEL NO. \_\_\_\_\_

### UNIT DATA

#### COOLING PERFORMANCE

TOTAL CAPACITY\* ..... MBH [kW]

SENSIBLE CAPACITY\* ..... MBH [kW]

OUTDOOR DESIGN TEMP. .... °F [°C] DB

TOTAL SUPPLY AIR ..... CFM [L/s]

TEMP. OF AIR ENTERING  
EVAPORATOR COIL ..... °F [°C] DB

..... °F [°C] WB

POWER INPUT REQUIREMENT ..... kW  
(\*uses blower motor heat)

#### HEATING PERFORMANCE

TOTAL CAPACITY\* ..... MBH [kW]

OUTDOOR DESIGN TEMP. .... °F [°C] DB

TEMP. OF AIR ENTERING  
EVAPORATOR COIL ..... °F [°C] DB

ELECTRIC HEAT CAPACITY ..... kW

POWER INPUT REQUIREMENT ..... kW  
(\*uses blower motor heat)

#### SUPPLY AIR BLOWER PERFORMANCE

TOTAL AIR SUPPLY ..... CFM [L/s]

TOTAL RESISTANCE EXTERNAL  
TO UNIT..... IWG

BLOWER SPEED ..... RPM

POWER OUTPUT REQUIREMENT .... BHP

MOTOR RATING ..... HP [W]

POWER INPUT REQUIREMENT ..... kW

#### ELECTRICAL DATA

POWER SUPPLY ..... Hz

TOTAL UNIT AMPACITY ..... AMPS

MINIMUM WIRE SIZE ..... AWG

MAXIMUM OVERCURRENT DEVICE  
FUSES/HACR BREAKER ..... AMPS

#### CLEARANCES

SERVICE ACCESS FRONT 24" [609.6 mm]

### FEATURES FOR SH2T

- SH2T feature a Constant Torque motor (ECM) which provides enhanced SEER performance with most outdoor units.
- Versatile 4-way convertible design for upflow, downflow, horizontal left and horizontal right applications.
- Factory-installed indoor coil.
- Sturdy cabinet construction with 1.0 inch [25.4 mm] ofoil faced insulation for excellent sound and insulating characteristics.
- Field-installed auxiliary electric heater kits provide exact heat for indoor comfort. Kits include circuit breakers which meet U.L. and cUL requirements for service disconnect.
- 1 1/2 ton [5.3 kW] through 5 ton [17.6 kW] models are between 42 1/2 to 57 inches [1080 to 1448 mm] tall and 22 inches [559 mm] deep.
- All models meet or exceed 330 to 400 CFM [156 to 189 L/s] per ton at .3 inches [.7 kPa] of external static pressure.
- Enhanced airflow up to .7" external static pressure.
- Evaporator is constructed of aluminum fins bonded to internally grooved aluminum tubing.
- Suitable for application in mobile homes.

[ ] Designates Metric Conversions



# Unit Dimensions

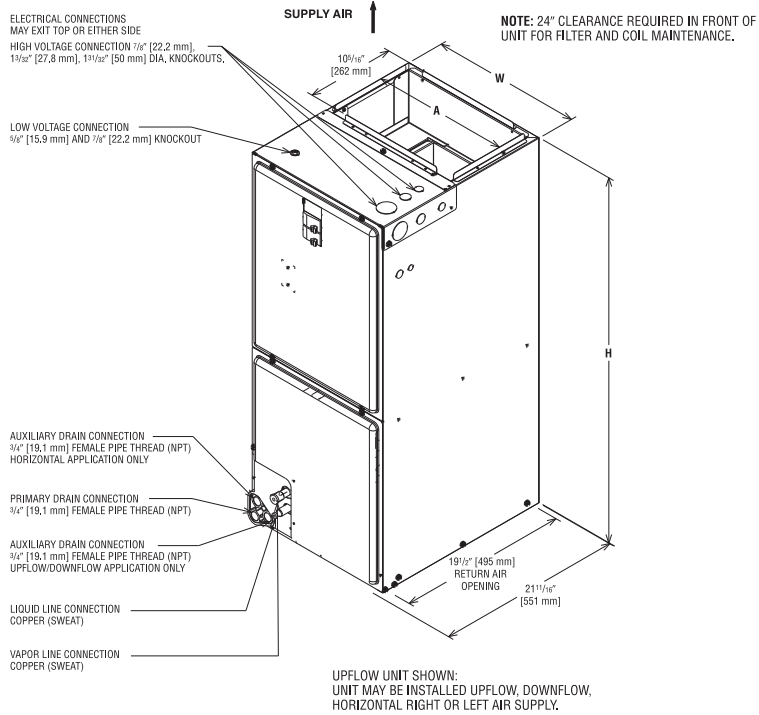

## Return Air Opening Dimensions

Model Cabinet Size	Return Air Opening Width (Inches)	Return Air Opening Depth/Length (Inches)
17	15 7/8	19 3/4
21	19 3/8	19 3/4
24	22 7/8	19 3/4

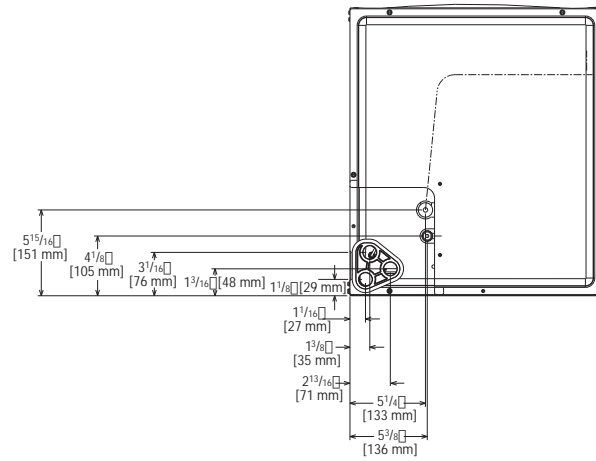
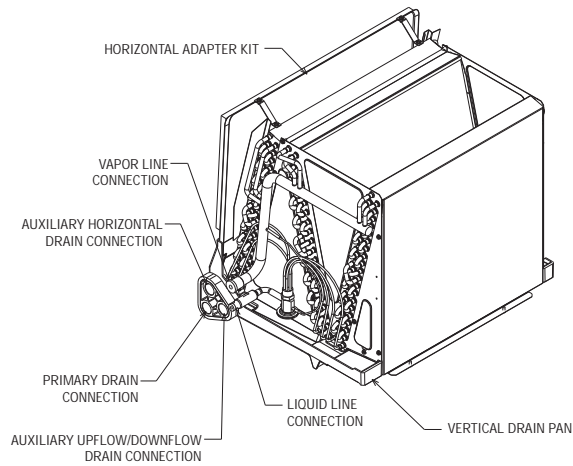

[ ] Designates Metric Conversions  
( ) Designates Unit with Double Coil Cabinet

## Unit Dimensions & Weights

Model Size SH2T	Refrigerant Connections Sweat (In.) [mm] ID		Unit Width "W" In. [mm]	Unit Height "H" In. [mm]	Supply Duct "A" In. [mm]	Air Flow CFM (Nom.) [L/s]		Unit Weight/Shipping Weight (Lbs.) [kg] Unit With Coil (Max. KW)
	Liquid	Vapor				Lo	Hi	
2417ST	3/8 [9.53]	3/4 [19.05]	17 1/2 [445]	42 1/2 [1080]	16 [406]	600 [283]	800 [378]	92/106 [42/48]
3617ST	3/8 [9.53]	3/4 [19.05]	17 1/2 [445]	42 1/2 [1080]	16 [406]	1000 [472]	1200 [566]	96/110 [44/50]
3621HT	3/8 [9.53]	7/8 [22.23]	21 [533]	57 [1448]	19 1/2 [495]	1000 [472]	1200 [566]	137/149 [62/68]
3621MT	3/8 [9.53]	7/8 [22.23]	21 [533]	50 1/2 [1282]	19 1/2 [495]	1000 [472]	1200 [566]	126/142 [57/64]
4821MT	3/8 [9.53]	7/8 [22.23]	21 [533]	57 [1448]	19 1/2 [495]	1400 [661]	1600 [755]	139/151 [63/68]
4821ST	3/8 [9.53]	7/8 [22.23]	21 [533]	50 1/2 [1282]	19 1/2 [495]	1400 [661]	1600 [755]	128/144 [56/65]
4824ST	3/8 [9.53]	7/8 [22.23]	24 1/2 [622]	50 1/2 [1282]	23 [585]	1600 [755]	—	142/160 [64/72]
6021ST	3/8 [9.53]	7/8 [22.23]	21 [533]	57 [1448]	19 1/2 [495]	1600 [755]	1725 [814]	139/151 [63/68]
6024ST	3/8 [9.53]	7/8 [22.23]	24 1/2 [622]	55 1/2 [1410]	23 [585]	—	1800 [850]	159/176 [72/80]



**Russell™ By Rheem**

5600 Old Greenwood Road, Fort Smith, AR 72908

Before proceeding with installation, refer to installation instructions packaged with each model, as well as complying with all Federal, State, Provincial, and Local codes, regulations, and practices.