



The new degree of comfort.™

Rheem *Classic*® Series Upflow/Horizontal Ultra Low NOx Gas Furnace

R801T- Upflow/Horizontal Series

80% A.F.U.E.†

Input Rates 50-100 kBTU



†A.F.U.E. (Annual Fuel Utilization Efficiency) calculated in accordance with Department of Energy test procedures.

- First certified unit to meet 14ng/j NOx emission standard
- Environmentally friendly and responsible product that reduces NOx emissions by 65%
- 80% residential Gas Furnace CSA certified
- 3 way multi poise design UF / HZ
- PlusOne™ Diagnostics – 7 Segment LED all units
- PlusOne™ Ignition System – DSI for reliability and longevity
- Heat exchanger is removable for improved serviceability. Stainless/Aluminized steel construction provides maximum corrosion resistance and thermal fatigue reliability.
- Solid doors provide quiet operation
- Solid bottom
- Insulated blower compartment
- Low profile 34" cabinet ideal for space constrained installations
- Blower shelf design – serviceable in all furnace orientations
- Hemmed edges on cabinets and doors
- 1/4 turn door knobs for tool less access
- Integrated Control board features dip switches for easy system set up
- QR code for quick access to product information from your smart phone or tablet
- Constant Torque electrically commutated motor
- Cabinet air leakage less than 2% at 1 inch H₂O when tested in accordance with ASHRAE standard 193





TABLE OF CONTENTS

Standard & Optional Equipment3

Model Features/Physical Data & Specifications4

Model Number Identification5

Dimensional Data6-7

Blower Performance Data8

Accessories9

Limited Warranty10



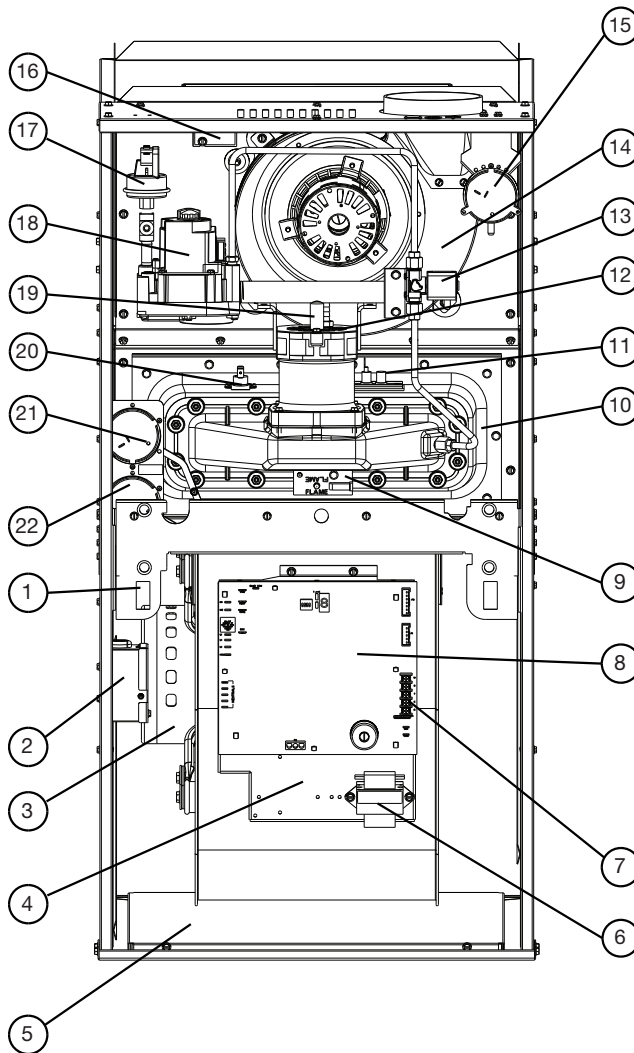

ITEM NO.	DESCRIPTION
1.	DOOR SWITCH
2.	JUNCTION BOX
3.	BLOWER MOTOR
4.	CONTROL MOUNTING PLATE
5.	SOLID METAL BASE PAN
6.	TRANSFORMER
7.	LOW VOLTAGE TERMINALS
8.	FURNACE CONTROL
9.	FLAME LED BOARD
10.	BURNER ASSEMBLY
11.	IGNITOR/FLAME SENSE
12.	COMBUSTION AIR INLET
13.	PILOT SOLENOID
14.	INDUCED DRAFT BLOWER
15.	AIR INLET PRESSURE SWITCH
16.	MAIN LIMIT
17.	GAS PRESSURE SWITCH
18.	GAS VALVE
19.	ORIFICE
20.	OVER-TEMPERATURE SWITCH
21.	COMBUSTION PRESSURE SWITCH
22.	IGNITION PRESSURE SWITCH

ST-A1252-01-00

STANDARD EQUIPMENT

Completely assembled and wired; induced draft; pressure switch; redundant main gas control; blower compartment door safety switch; solid state time on/time off blower control; limit control; manual shut-off valve, pressure regulator for natural gas; transformer; direct drive multi-speed blower motor. Furnaces are equipped with cooling/heating relay and transformer (40VA) ready for air conditioning applications. (Please note: a thermostat is not included as standard equipment.) Flame sensor diagnostics.

OPTIONAL EQUIPMENT

Side and bottom filter frame assembly. Return air cabinet for all sizes.
 NOTE: Furnace is not listed for use with fuel other than natural gas.
 The complete terms of limited and other warranties are available at our sales office, or through local installer.
 NOTE: For natural gas models, direct spark ignition is 100% safety lockout type.

WARNING
 THIS FURNACE IS NOT APPROVED
 OR RECOMMENDED
 FOR USE IN MOBILE HOMES



Model Features

- 80% residential Gas Furnace CSA certified
- 3 way multi poise design UF / HZ
- PlusOne™ Diagnostics – 7 Segment LED all units
- PlusOne™ Ignition System – DSI for reliability and longevity
- Heat exchanger is removable for improved serviceability. Aluminized steel construction provides maximum corrosion resistance and thermal fatigue reliability.
- Solid doors provide quiet operation
- Solid bottom
- Insulated blower compartment
- Low profile 34" cabinet ideal for space constrained installations
- Blower shelf design serviceable in all furnace orientations
- Hemmed edges on cabinets and doors
- 1/4 turn door knobs for tool less access
- Integrated Controls board features dip switches for easy system set up
- QR code for quick access to product information from your smart phone or tablet
- Constant Torque electrically commutated motor

Physical Data and Specifications

MODEL NUMBERS R801T SERIES	R801TA050317MUA	R801TA050417MUA	R801TA070317MUA	R801TA070417MUA	R801TA100521MUA	R801TB100521MUA
Input-BTU/Hr [kW] ②	50,000 [14.6]	50,000 [14.6]	70,000 [20.5]	70,000 [20.5]	100,000 [29]	100,000 [29]
Heating Capacity BTU/Hr [kW] ①	40,000 [11.7]	40,000 [11.7]	56,000 [16.4]	56,000 [16.4]	80,000 [23.4]	80,000 [23.4]
Heat Ext. Static Pressure [kPa]	.18 [.05]	.18 [.05]	.20 [.05]	.20 [.05]	.28 [.07]	.28 [.07]
Blower (D x W) [mm]	11 x 6 [279 x 152]	11 x 6 [279 x 152]	11 x 7 [279 x 178]	11 x 7 [279 x 178]	11 x 10 [279 x 254]	11 x 10 [279 x 254]
Motor H.P.–Speed– Type [W]	1/2-5 Spd Constant Torque [373]	3/4-5 Spd Constant Torque [560]	1/2-5 Spd Constant Torque [373]	3/4-5 Spd Constant Torque [560]	3/4-5 Spd Constant Torque [560]	1-5 Spd Constant Torque [746]
Min. Circuit Ampacity	10	11	9	12	13	16
Min. Overload Protection Device	15	15	15	15	15	20
Max. Overload Protection Device	15	15	15	15	15	25
Heating Speed	Low	Low	Med	Med	Med	Med
Cooling Speed	Med-High	High	High	High	High	High
Cooling CFM @ Rating Point [L/s]	1139 [538]	1431 [675]	1135 [536]	1602 [756]	1714 [809]	1979 [934]
Max. E.S.P. (In. W.C.) [kPa]	0.9 [.22]	0.9 [.22]	0.9 [.22]	0.9 [.22]	0.9 [.22]	0.9 [.22]
Temperature Rise Range °F [°C]	35-65 [19.4-36.1]	35-65 [19.4-36.1]	35-65 [19.4-36.1]	35-65 [19.4-36.1]	35-65 [19.4-36.1]	35-65 [19.4-36.1]
Max. Outlet Air Temp. °F [°C]	180 [82.2]	180 [82.2]	180 [82.2]	180 [82.2]	180 [82.2]	180 [82.2]
Approx. Shipping Weight (Lbs.) [kg]	125 [57]	125 [57]	125 [57]	125 [57]	140 [64]	140 [64]
AFUE ①	80.0%	80.0%	80.0%	80.0%	80.0%	80.0%

NOTES: All models are 115V, 60HZ, 1 Ph. Gas connection size for all models is 1/2" [12 mm] N.P.T.

① In accordance with D.O.E. test procedures.

② This model does not require any component changes at elevations 0-5,500 ft. above sea level. At elevations higher than 2,000 ft. these models do require a 2% de-rate for every 1,000 ft. of elevation above sea level.

This furnace meets air district requirements of 14 ng/J NOx emissions limit, and thus is eligible for the Clean Air Furnace Rebate Program:
www.CleanAirFurnaceRebate.com in SCAQMD.

[] Designates Metric Conversions





Model Number Identification

<u>R</u>	<u>80</u>	<u>1</u>	<u>T</u>	<u>A</u>	<u>070</u>	<u>4</u>	<u>17</u>	<u>M</u>	<u>U</u>	<u>A</u>
Rheem	80 = 80% AFUE	1 = Single Stage	T = Constant Torque	Design Series A = 1st Design B = 2nd Design	Input BTU/HR [kW] 050 = 50,000 [15] 070 = 70,000 [22] 100 = 98,000 [29]	3 = 1½ to 3½ Ton 4 = 1½ to 4 Ton 5 = 2½ to 5 Ton	Cabinet Width 17 = 17.5" 21 = 21"	M = Multi	U = Ultra Low NOx	Revision- Marketing (A – First Time Release)

[] Designates Metric Conversions

Upflow Application

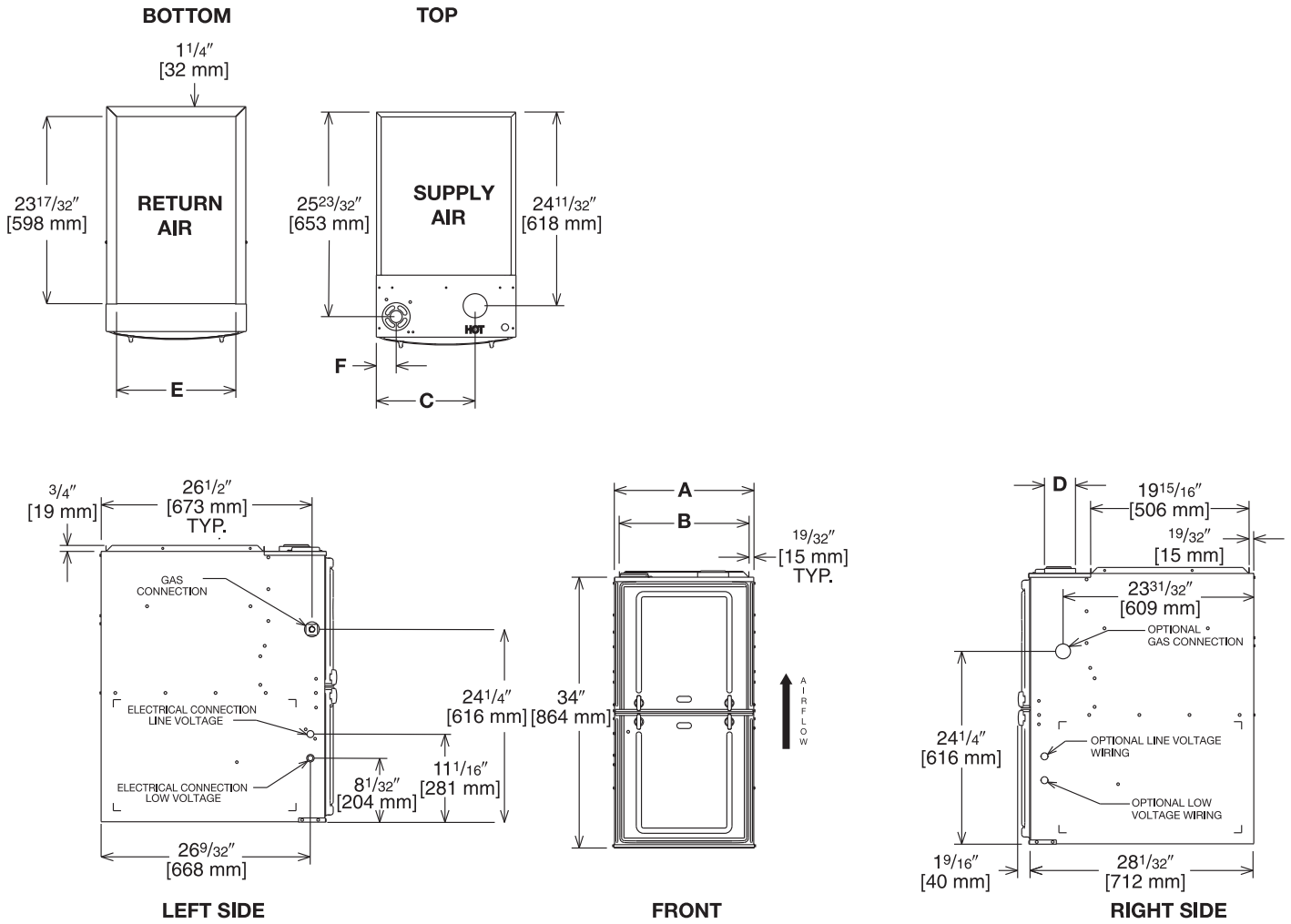

Illustration
ST-A1220-04-00
FIGURE 1

Dimensional Data: Upflow Model

MODEL R801T-	A	B	C	D	E	F	MINIMUM CLEARANCE (IN.) [mm]					SHIP WGTS. (LBS.) [kg]	
							LEFT SIDE	RIGHT SIDE	BACK	TOP	FRONT		VENT
050/070	17 1/2 [445]	16 11/32 [415]	12 3/8 [314]	①	15 [381]	2 1/2 [64]	0	3 [76] ②	0	1 [25]	3 [76]	6 [152] ③	125 [57]
100	21 [533]	19 27/32 [504]	14 1/8 [359]	①	18 1/2 [470]	2 1/2 [64]	0	0	0	1 [25]	3 [76]	6 [152] ③	140 [64]

NOTES: ① May require a 3" [76 mm] to 4" [102 mm] or 3" [76 mm] to 5" [127 mm] adapter.

② May be 0" [0 mm] with type B vent.

③ May be 1" [25 mm] with type B vent.

Furnaces must be vented in accordance with the National Fuel Gas Code, ANSI Z223.1 and in accordance with local codes.

[] Designates Metric Conversions

Horizontal Application

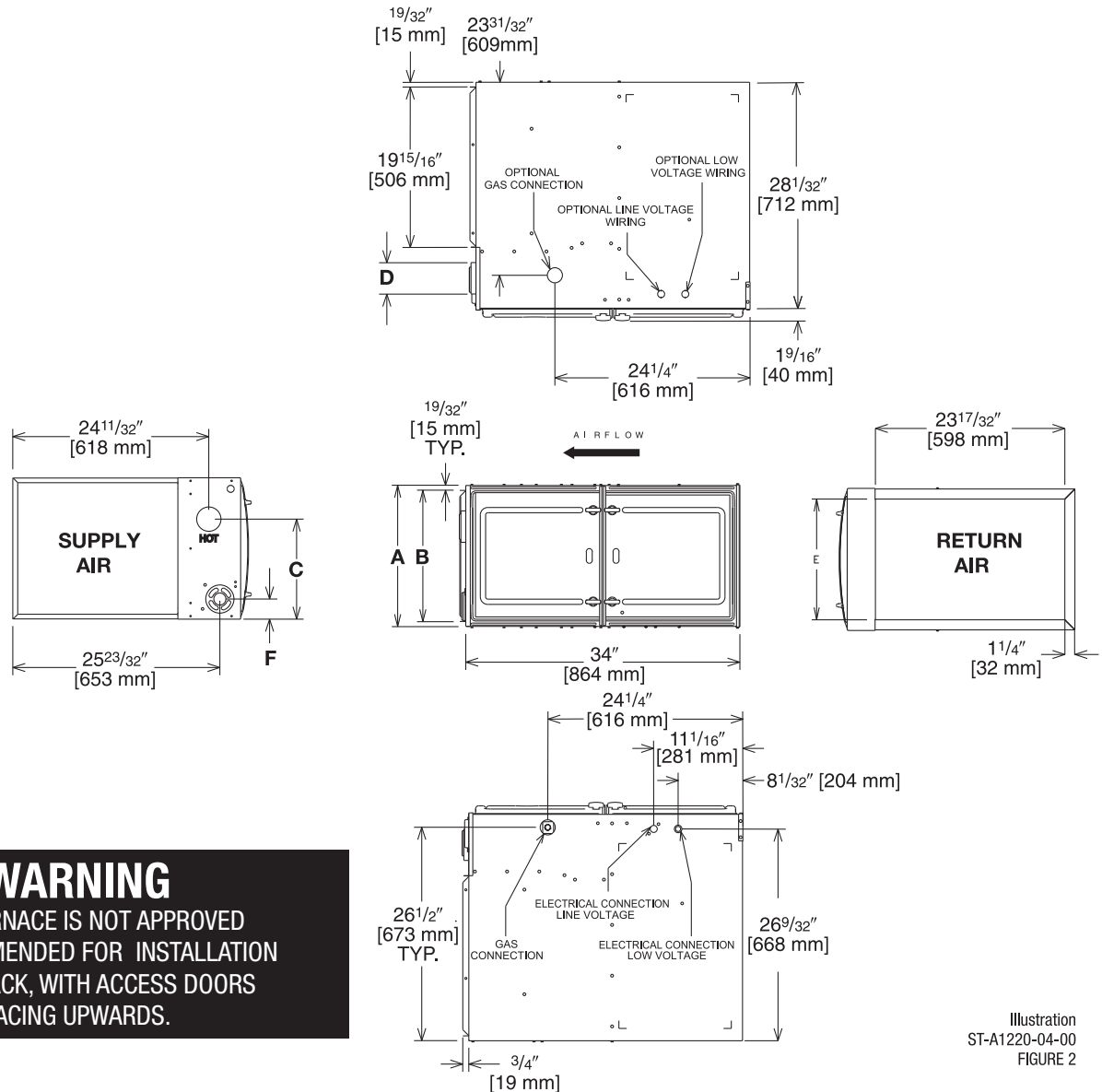
 Illustration
 ST-A1220-04-00
 FIGURE 2

WARNING
 THIS FURNACE IS NOT APPROVED
 OR RECOMMENDED FOR INSTALLATION
 ON ITS BACK, WITH ACCESS DOORS
 FACING UPWARDS.

Dimensional Data: Horizontal Model

MODEL R801T-	A	B	C	D	E	F	MINIMUM CLEARANCE (IN.) [mm]					SHIP WGTS. (LBS.) [kg]	
							SUPPLY AIR SIDE	RETURN AIR SIDE	BACK	TOP	FRONT		VENT
050/070	17 1/2 [445]	16 1/32 [415]	12 3/8 [314]	①	15 [381]	2 1/2 [64]	3 [76] ②	3 [76] ②	0	1 [25]	3 [76]	6 [152] ③	125 [57]
100	21 [533]	19 27/32 [504]	14 1/8 [359]	①	18 1/2 [470]	2 1/2 [64]	0	0	0	1 [25]	3 [76]	6 [152] ③	140 [64]

NOTES: ① May require a 3" [76 mm] to 4" [102 mm] or 3" [76 mm] to 5" [127 mm] adapter.

② May be 0" [0 mm] with type B vent.

③ May be 1" [25 mm] with type B vent.

Furnaces must be vented in accordance with the National Fuel Gas Code, ANSI Z223.1 and in accordance with local codes.

[] Designates Metric Conversions

Blower Performance Data

AIR FLOW PERFORMANCE - (-)801T SERIES MODELS												
MODEL INPUT	MOTOR H.P. [W] BLOWER SIZE IN [mm]	AIRFLOW CONTROL SETTINGS	MOTOR SPEED	CFM AIR DELIVERY EXTERNAL STATIC PRESSURE " OF W.C. [kPa]								
				0.1 [.02]	0.2 [.05]	0.3 [.07]	0.4 [.10]	0.5 [.12]	0.6 [.15]	0.7 [.17]	0.8 [.20]	0.9 [.22]
				17" CAB 3 Ton/50K	1/2 [373] 11 X 6 [279 X 152]	Factory Heat	Low	783	709	664	610	559
Factory Fan	Med-Low	987	942			902	866	833	793	755	713	675
Option Cool 2.5 Tons	Med	1126	1096			1064	1030	996	966	934	897	869
Factory Cool 3 Tons	Med-High	1305	1276			1252	1221	1195	1164	1139	1110	1084
Option Cool 3.5 Tons	High	1410	1377			1353	1327	1310	1284	1259	1233	1210
17" CAB 4 Ton/50K	3/4 [559] 11 X 6 [279 X 152]	Factory Fan	Low	779	708	659	612	557	511	470	438	395
		Option Cool 2 Tons	Med-Low	982	949	906	869	832	794	756	716	680
		Factory Heat	Med	1116	1086	1057	1020	992	961	930	896	870
		Option Cool 3 Tons	Med-High	1301	1274	1244	1216	1191	1165	1137	1111	1086
		Factory Cool 4 Tons	High	1583	1555	1527	1504	1481	1453	1431	1405	1386
17" CAB 3 Ton/70K	1/2 [373] 11 X 7 [279 X 177]	Factory Fan	Low	892	834	783	729	674	623	568	518	472
		Option Cool 2 Tons	Med-Low	1047	1004	958	909	860	814	764	721	682
		Factory Heat	Med	1141	1097	1059	1016	971	929	884	844	803
		Factory Cool 3 Tons	Med-High	1357	1316	1283	1243	1204	1169	1135	1091	1055
		Option Cool 3.5 Tons	High	1493	1462	1424	1390	1358	1327	1291	1262	1229
17" CAB 4 Ton/70K	3/4 [559] 11 X 7 [279 X 178]	Factory Fan	Low	889	841	784	730	671	620	510	510	460
		Option Cool 2 Tons	Med-Low	1046	1002	949	904	852	811	762	723	679
		Factory Heat	Med	1141	1097	1059	1016	971	929	884	844	803
		Option Cool 3 Tons	Med-High	1363	1327	1288	1255	1210	1175	1135	1097	1068
		Factory Cool 4 Tons	High	1785	1745	1714	1688	1661	1627	1602	1569	1551
21" CAB 5 Ton/100K	3/4 [559] 11 X 10 [279 X 254]	Factory Fan	Low	1098	1064	1017	975	922	861	806	767	698
		Option Cool 3.5 Tons	Med-Low	1373	1331	1297	1267	1228	1182	1131	1076	1023
		Factory Heat	Med	1499	1474	1443	1419	1389	1353	1310	1272	1226
		Option Cool 4 Tons	Med-High	1668	1644	1612	1595	1570	1536	1509	1466	1427
		Factory Cool 5 Tons	High	1870	1849	1815	1785	1771	1736	1714	1681	1607
21" CAB 5 Ton/100K	1[746] 11 X 10 [279 X 254]	Factory Fan	Low	838	773	700	623	561	485	408	331	267
		Option Cool 3.5 Tons	Med-Low	1451	1414	1380	1344	1311	1277	1230	1181	1132
		Factory Heat	Med	1529	1488	1461	1421	1393	1355	1314	1279	1232
		Option Cool 4 Tons	Med-High	1602	1569	1529	1501	1470	1439	1404	1367	1318
		Factory Cool 5 Tons	High	2124	2098	2074	2047	2024	1996	1979	1943	1905

[] Designates Metric Conversions



**BOTTOM RETURN FILTER RACK FOR
UPFLOW APPLICATION: RXGF-CB**

SIDE RETURN FILTER RACK: RXGF-CD

FILTER RACK FILTER SIZES* INCHES [mm]		
MODEL	RXGF-CB (UPFLOW/ HORIZONTAL)	RXGF-CD (UPFLOW) SIDE RETURN
R801TA050/ R801TA070	15 ³ / ₄ x 25 [400 x 635]	15 ³ / ₄ x 25 [400 x 635]
R801TA100	19 ¹ / ₄ x 25 [489 x 635]	15 ³ / ₄ x 25 [400 x 635]

4" FLUE ADAPTER: RXGW-C01

INDOOR COIL CASINGS

MODEL NUMBER
RXBC-D17AI
RXBC-D21AI
RXBC-D21BI

WARNING: IMPORTANT NOTICE

A SOLID METAL BASE PLATE (SEE TABLE) MUST BE IN PLACE WHEN THE FURNACE IS INSTALLED WITH SIDE AIR RETURN DUCTS. FAILURE TO INSTALL A BASE PLATE COULD CAUSE PRODUCTS OF COMBUSTION TO BE CIRCULATED INTO THE LIVING SPACE AND CREATE POTENTIALLY HAZARDOUS CONDITIONS.

FURNACE WIDTH IN. [mm]	SOLID BOTTOM KIT NO.	BASE PLATE NO.	BASE PLATE SIZE IN. [mm]
17 ¹ / ₂ [445]	RXGB-D17	AE-61874-02	15 ¹ / ₈ x 23 ⁹ / ₁₆ [384 x 598]
21 [533]	RXGB-D21	AE-61874-03	18 ⁵ / ₈ x 23 ⁹ / ₁₆ [473 x 598]

[] Designates Metric Conversions





Air

GENERAL TERMS OF LIMITED WARRANTY*

Rheem will furnish a replacement for any part of this product which fails in normal use and service within the applicable period stated, in accordance with the terms of the limited warranty.

***For complete details of the Limited and Conditional Warranties, including applicable terms and conditions, contact your local contractor or the Manufacturer for a copy of the product warranty certificate.**

Conditional Parts* (Registration Required)Ten (10) Years
Heat ExchangerTwenty (20) Years





Air

Notes

R801T (UF/HZ) Ultra Low NOx Series



INTEGRATED HOME COMFORT



The new degree of comfort.™

In keeping with its policy of continuous progress and product improvement, Rheem reserves the right to make changes without notice.

Rheem Heating, Cooling & Water Heating • 5600 Old Greenwood Road
Fort Smith, Arkansas 72908 • www.rheem.com

Rheem Canada Ltd./Ltée • 125 Edgeware Road, Unit 1
Brampton, Ontario • L6Y 0P5



INTEGRATED HOME COMFORT

PRINTED IN U.S.A. 9/21 QG FORM NO. G11-556 REV. 8