



RussellTM
By Rheem

SUBMITTAL COVER SHEET

PROJECT NAME _____

LOCATION _____

ARCHITECT _____

ENGINEER _____

CONTRACTOR _____

SUBMITTED BY _____ DATE _____

UNIT SUMMARY

Quantity						
Unit Designation						
Model No.						
Total Cooling						
Sensible Cooling						
Air Ent. Evaporator						
Air Lvg. Evaporator						
Heating Input						
Heating Output						
CFM/ESP						
EER/SEER						
Electrical						
Minimum Ampacity						
Min.-Max. Breaker						
Net Unit Weight						
Accessory						
Catalog Form Number						

ACCESSORIES:

NOTES:

SUBMITTAL SHEET FOR PACKAGE GAS ELECTRIC RGEC SERIES Nominal Sizes 3-6 Tons [10.6-21.1 kW]

JOB NAME _____
 CONTRACTOR _____
 ENGINEER _____
 LOCATION _____
 ORDER NO. _____
 SUBMITTED FOR APPROVAL RECORD
 SUBMITTED BY _____
 DATE _____
 UNIT DESIGNATION _____
 MODEL NO. _____

FEATURES FOR RGEC SERIES PACKAGE GAS ELECTRIC UNITS

- Factory charged with R-410A HFC refrigerant
- Wired and run tested
- Scroll compressors with internal line break overload and high pressure protection
- Convertible airflow – vertical down flow or horizontal side flow
- Forkable base rails for easy handling and lifting
- Cooling operation up to 125°F ambient
- Two-stage gas heat input with direct spark ignition system, solid state furnace controls, and optimized induced draft combustion
- MicroChannel evaporator and condenser coil
- ServiceSmart package includes:
 Qwik-Change Flex-Fit Rack™
 Qwik-Slide Blower Assembly™
 Qwik-Clean Drain Pan™
- Over-flow condensate sensor
- Diagnostics with Dual 7-Segment LED Display to meet code compliance
- One-piece top cover and base pan with drawn supply and return opening
- Two-piece control door
- ¼ turn fasteners on filter access door
- Color-coded and labeled wiring
- External lockable gauge ports
- TXV refrigerant metering system
- Solid-core liquid line filter drier
- High pressure and low pressure/loss of charge protection with built-in Smart Logic
- Insulation encapsulated throughout entire unit
- New product footprint with matching connections
- Improved factory lead times
- 6 Ton includes a single 2-Stage compressor
- 3-5 Ton includes one single-stage compressor

UNIT DATA

COOLING PERFORMANCE

TOTAL CAPACITY* MBH
 SENSIBLE CAPACITY* MBH
 OUTDOOR DESIGN TEMP. ... °F [°C] DB/WB
 TOTAL SUPPLY AIR CFM [L/s]
 TEMP. OF AIR ENTERING
 EVAPORATOR COIL °F [°C] DB/WB
 POWER INPUT REQUIREMENT kW
 SEER/EER RATING
 (*uses blower motor heat)

HEATING PERFORMANCE

GAS HEAT INPUT CAPACITY MBH
 GAS HEAT OUTPUT CAPACITY MBH
 STEADY STATE EFFICIENCY

SUPPLY AIR BLOWER PERFORMANCE

TOTAL SUPPLY AIR CFM [L/s]
 TOTAL RESISTANCE EXTERNAL
 TO UNIT IWG
 BLOWER SPEED RPM
 POWER OUTPUT REQUIREMENT BHP
 MOTOR RATING HP [W]
 POWER INPUT REQUIREMENT kW

ELECTRICAL DATA

POWER SUPPLY Hz
 TOTAL UNIT AMPACITY AMPS
 MINIMUM WIRE SIZE AWG
 MAXIMUM OVERCURRENT DEVICE
 FUSES HACR BREAKER AMPS

TOTAL UNIT WEIGHT

TOTAL OPERATING WEIGHT LBS [kg]
 (including field-installed accessories)

CLEARANCES

FRONT	48" [1219 mm]
CONDENSER COIL	18" [457 mm]
DUCT SIDE	12" [305 mm]
EVAPORATOR END	36" [914 mm]
ABOVE UNIT	60" [1524 mm]

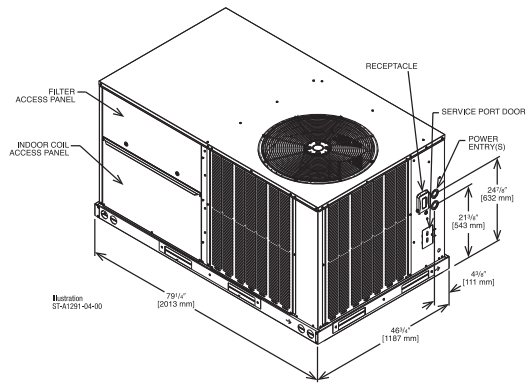
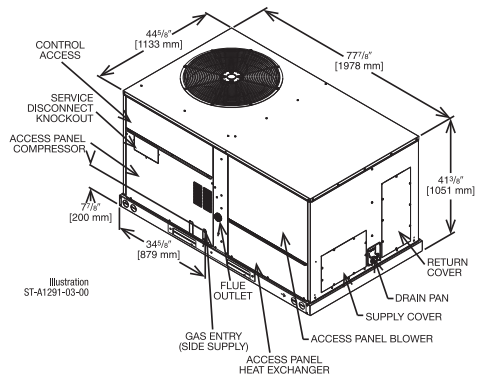

SUPPLY AND RETURN DIMENSIONS FOR HORIZONTAL APPLICATIONS

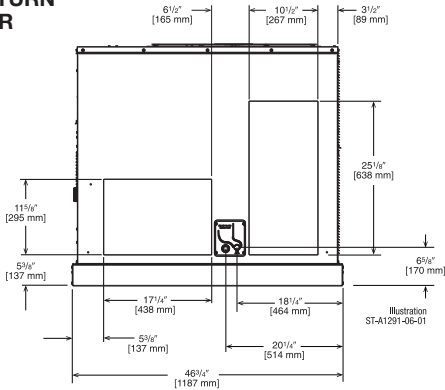

SUPPLY AND RETURN DIMENSIONS FOR DOWNFLOW APPLICATIONS

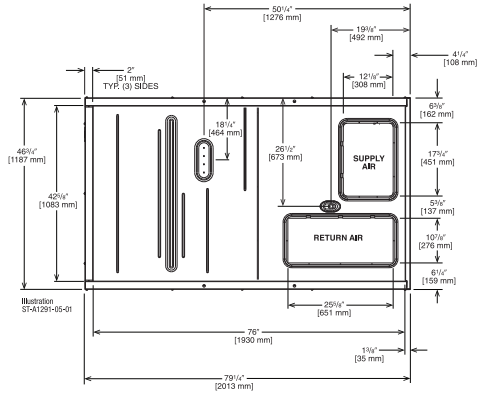

[] Designates Metric Conversions

Accessory	Model Number
Economizer w/Single Enthalpy (Downflow/Vertical)	RXRD-01MCDAM3
Economizer w/Single Enthalpy (Horizontal)	RXRD-01MCHAM3
Economizer-w/Single Enthalpy (Downflow/Vertical) DDC	RXRD-01MCDBM3
Economizer w/Single Enthalpy (Horizontal) DDC	RXRD-01MCHBM3
Dual Enthalpy Kit	RXXR-BV01
Dual Enthalpy Kit DDC	RXXR-BV02
Power Exhaust (230V) Vertical	RXXR-CCF02C
Power Exhaust (460V) Vertical	RXXR-CCF02D
Power Exhaust (230V) Horizontal	RXXR-CCF03C
Power Exhaust (460V) Horizontal	RXXR-CCF03D
Manual Fresh Air Damper	RXRF-ACA1
Motorized Fresh Air Damper	RXRF-ACB1
Roofcurb, 14"	RXKG-DCC14
Roofcurb, 24"	RXKG-DCC24
Roofcurb Adapter	RXXR-DCCAE
Concentric Diffuser 3-4 Ton Flush	RXRN-AEF1800
Concentric Diffuser 5-6 Ton Flush	RXRN-AEF2000
Concentric Diffuser 3-4 Ton Drop	RXRN-AED1800
Concentric Diffuser 5-6 Ton Drop	RXRN-AED2000
Concentric Adapter 3-4 Ton Drop	RXMC-DC01

Accessory	Model Number
Concentric Adapter 5-6 Ton Drop	RXMC-DC02
Outdoor Coil Louver Kit	RXXR-ADD04C
Nonpowered Convenience Outlet	RXXR-BN01
Unfused Service Disconnect	RXXR-BP01
Comfort Alert (1 Phase) DDC	RXXR-AZ03
Comfort Alert (1 Phase) Non-DDC	RXXR-AZ04
Comfort Alert (3 Phase) DDC	RXXR-AZ01
Comfort Alert (3 Phase) Non-DDC	RXXR-AZ02
Carbon Dioxide Sensor (Wall Mount)	RXXR-AR02
BACnet Communication Card	RXXR-AY01
LonWorks Communication Card	RXXR-AY02
Room Humidity Sensor	RHC-ZNS4
Room Temperature and Relative Humidity Sensor	RHC-ZNS5
Low-Ambient Control Kit	RXRZ-A04
Freeze Stat Kit	RXXR-AM05
Return Smoke Detector (Field kit)	RXXR-BS01
Return/ Supply Smoke Detector (Field kit)	RXXR-BS02
LP Kit (-)GEC 75K, 120K	RXGJ-FP40
LP Kit (-)GEC 100K	RXGJ-FP41
Flue Diverter (-)GEC 75K, 100K & 120K	RXXR-GE03



Russell™ By Rheem
5600 Old Greenwood Road, Fort Smith, AR 72908

Before proceeding with installation, refer to installation instructions packaged with each model, as well as complying with all Federal, State, Provincial, and Local codes, regulations, and practices.