



**Russell**<sup>TM</sup>  
By Rheem

## SUBMITTAL COVER SHEET

PROJECT NAME \_\_\_\_\_

LOCATION \_\_\_\_\_

ARCHITECT \_\_\_\_\_

ENGINEER \_\_\_\_\_

CONTRACTOR \_\_\_\_\_

SUBMITTED BY \_\_\_\_\_ DATE \_\_\_\_\_

### UNIT SUMMARY

Quantity						
Unit Designation						
Model No.						
Total Cooling						
Sensible Cooling						
Air Ent. Evaporator						
Air Lvg. Evaporator						
Heating Input						
Heating Output						
CFM/ESP						
EER/SEER						
Electrical						
Minimum Ampacity						
Min.-Max. Breaker						
Net Unit Weight						
Accessory						
Catalog Form Number						

**ACCESSORIES:**

**NOTES:**



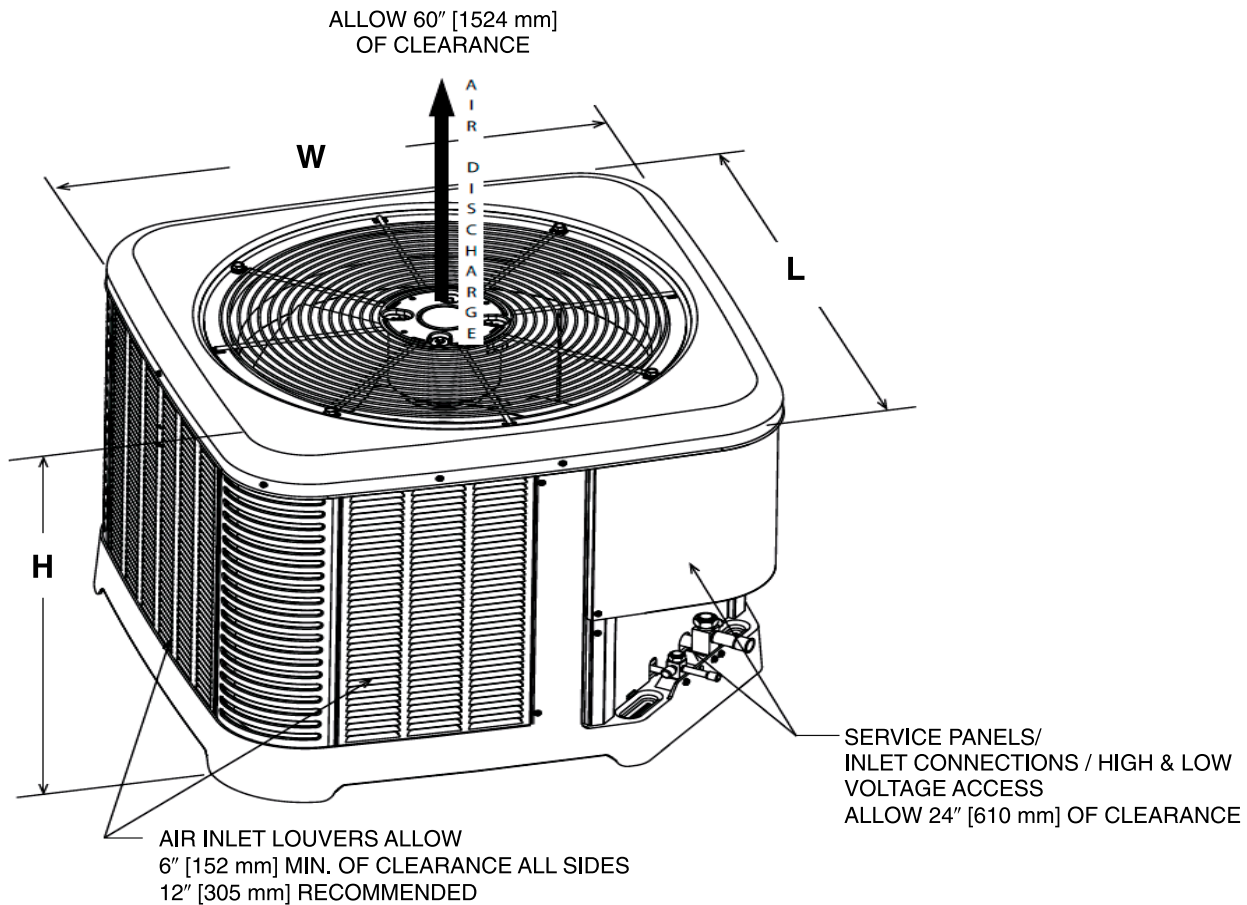

ST-A1226-02-00

## Unit Dimensions

MODEL NO.	OPERATING						SHIPPING					
	H (Height)		L (Length)		W (Width)		H (Height)		L (Length)		W (Width)	
	INCHES	mm	INCHES	mm	INCHES	mm	INCHES	mm	INCHES	mm	INCHES	mm
SA1724	35	889	33.75	857	33.75	857	36.75	933	36.38	924	36.38	924
SA1736	39	990	33.75	857	33.75	857	40.75	1035	36.38	924	36.38	924
SA1748	51	1295	35.75	908	35.75	908	52.75	1339	38.38	974	38.38	974
SA1760	51	1295	35.75	908	35.75	908	52.75	1339	38.38	974	38.38	974

[ ] Designates Metric Conversions



**Russell™ By Rheem**

5600 Old Greenwood Road, Fort Smith, AR 72908

Before proceeding with installation, refer to installation instructions packaged with each model, as well as complying with all Federal, State, Provincial, and Local codes, regulations, and practices.