



MODEL: SA17

Two-Stage Air Conditioners

FORM NO. ARR-226



Russell™ By Rheem SA17 Two-Stage Air Conditioners

- **Efficiencies up to 17 SEER/13 EER**
Nominal Sizes 2, 3, 4 & 5 Ton
[7.03, 10.6, 14.06 & 17.6 kW]
Cooling Capacities 17.3 to 60.5 kBTU
[5.7 to 17.7 kW]



“Proper sizing and installation of equipment is critical to achieve optimal performance. Split system air conditioners and heat pumps must be matched with appropriate coil components to meet Energy Star. Ask your Contractor for details or visit www.energystar.gov.”

- **New Composite Base Pan** – dampens sound, wire grille, eliminates corrosion and reduces number of fasteners needed
- **Powder Coat Paint System** – for a long lasting professional finish
- **The Two-Stage Copeland Scroll™ UltraTech™ Compressor** modulates between two capacity settings – 67% and 100% – providing more precise temperature control, lower humidity and greater efficiency in comparison to single stage compressors. It uses 70% fewer moving parts which also increases efficiency and reliability.
- **Modern Cabinet Aesthetics** – increased curb appeal with visually appealing design
- **Wire Grille** – provide ultimate coil protection, enhance cabinet strength, and increased cabinet rigidity
- **Optimized Fan Orifice** – optimizes airflow and reduces unit sound
- **Rust Resistant Screws** – confirmed through 1500-hour salt spray testing
- **Service Valve Has Between 3"-4"-5" Valve Space** – provides a minimum working area of 27-square inches for easier access
- **15" Wide, Industry Leading Corner Service Access** – makes repairs easier and faster.
- **External Gauge Port Access** – allows easy connection of “low-loss” gauge ports
- **Single-Row Condenser Coil** – makes unit lighter and allows thorough coil cleaning to maintain “out of the box” performance
- **Fewer Cabinet Fasteners** – allow for faster access to internal components and hassle-free panel removal
- **Service Trays** – hold fasteners or caps during service calls
- **QR Code** – provides technical information on demand for faster service calls
- **Fan Motor Harness With Extra Long Wires** allows unit top to be removed without disconnecting fan wire.
- **High And Low Pressure Standard** on all models.

TABLE OF CONTENTS

Standard Feature	3
Available SKUs	3
Features & Benefits	4-5
Model Number Identification	6
General Data/Electrical Data	7
Accessories	8
Weighted Sound Power	8
Unit Dimensions.....	9
Clearances.....	10
Wiring Diagrams	11
Application Guidelines.....	11
Refrigerant Line Size Information.....	12-13
Performance Data	14
Guide Specifications	15
Limited Warranty	16

Standard Feature Table

Feature	STANDARD FEATURES			
	24	36	48	60
R-410A Refrigerant	√	√	√	√
Maximum SEER	17	17	17	16
Maximum EER	13	13	13	12.5
Two Stage Copeland Scroll™ UltraTech™ Compressor	√	√	√	√
Field Installed Filter Drier	√	√	√	√
Front Seating Service Valves	√	√	√	√
Internal Pressure Relief Valve	√	√	√	√
Internal Thermal Overload	√	√	√	√
Long Line capability	√	√	√	√
Low Ambient capability with Kit	√	√	√	√
Expanded Valve Space	√	√	√	√
Composite Basepan	√	√	√	√
1 Screw Control Box Access	√	√	√	√
15" Access to Internal Components	√	√	√	√
Optimized Venturi Airflow	√	√	√	√
Single row condenser coil	√	√	√	√
Powder coated paint	√	√	√	√
Rust resistant screws	√	√	√	√
QR code	√	√	√	√
External gauge ports	√	√	√	√
Service trays	√	√	√	√

√ = Standard

Available SKUs

Available Models
SA1724AJ2NA
SA1724AJ2NB*
SA1736AJ2NA
SA1736AJ2NB*
SA1748AJ2NA
SA1748AJ2NB*
SA1760AJ2NA
SA1760AJ2NB*

*High and low pressure control models

Introduction to SA17 Air Conditioner

The SA17 is our 17 SEER air conditioner and is part of the Russell™ By Rheem air conditioner product line that extends from 13 to 17 SEER. This highly featured and reliable air conditioner is designed for years of reliable, efficient operation when matched with Russell™ By Rheem indoor aluminum evaporator coils and furnaces or air handler units with aluminum evaporators.

Our unique composite base (1) reduces sound emission, eliminates rattles, reduces fasteners, eliminates corrosion and has integrated brass compressor attachment inserts (2). Furthermore it has incorporated into the design, water management features, means for hand placement (3) for unit maneuvering, screw trays (4) and inserts for lifting off unit pad. (5)

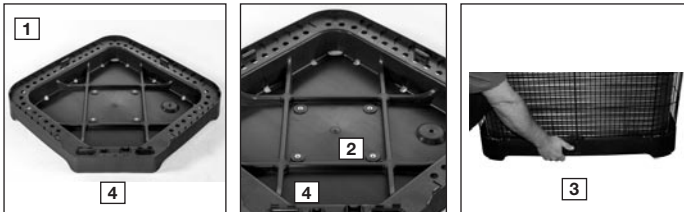

Service Valves (6) are rigidly mounted in the composite base with 3" between suction and discharge valves, 4" clearance below service valves and a minimum of 5" above the service valves, creating industry leading installation ease.

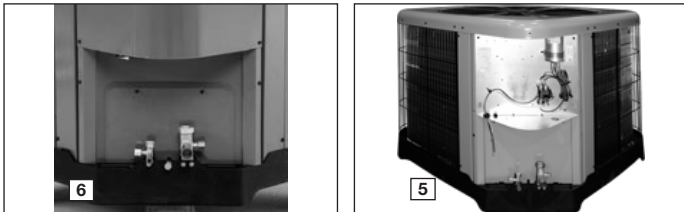

The minimum 27 square-inches around the service valves allows ample room to remove service valve schrader prior to brazing, plenty of clearance for easy brazing of the suction and discharge lines to service valve outlets, easy access and hookup of low loss refrigerant gauges (7), and access to the service valve caps for opening. For applications with long-line lengths up to 250 feet total equivalent length, up to 200 feet condenser above evaporator, or up to 80 feet evaporator above condenser, the long-line instructions in the installation manual should be followed.

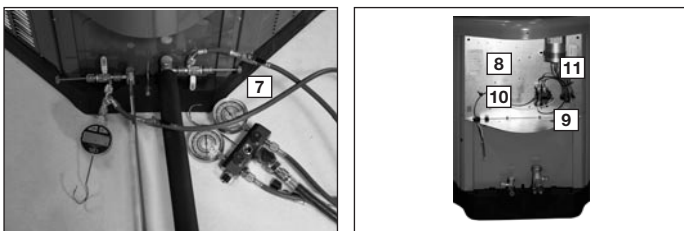

Controls are accessed from the corner of the unit by removing only three fasteners from the control access cover, revealing the industry's largest 15" wide and 14" tall control area (8). With all this room in the control area the high voltage electrical whip (9) can easily be inserted through the right size opening in the bottom of the control area. Routing it leads directly to contractor lugs for connection. The low voltage control wires (10) are easily connected to units low voltage wiring. If contactor or capacitor (11) needs to be replaced there is more than adequate space to make the repair.

If in the rare event, greater access is needed to internal components, such as the compressor, the top cover can be removed easily. Furthermore with the top cover removed the control panel can be removed (12). Extra wire length is incorporated into each outdoor fan and compressor so top cover and control panel can be positioned next to the unit. With minimal effort the plug can be removed from the compressor and the outdoor fan wires can be removed from the capacitor to allow even more uncluttered access to the interior of the unit (13). Outdoor coil heights range from as short as 22" to 32", aiding access to the compressor. Disassembly to this degree and complete reassembly only takes a first time service technician less than 10 minutes. (13)

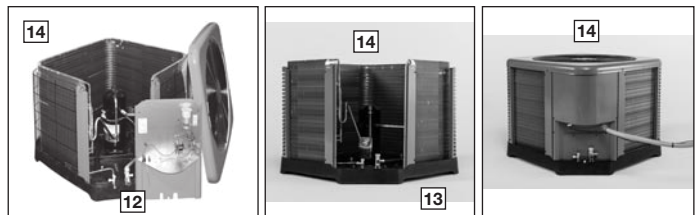

All SA17 units utilize single row coils (14) making cleaning easy and complete, restoring the performance of the air conditioner back to out of the box performance levels year after year.

The outdoor fan motor has sleeve bearings and is inherently protected. The motor is totally enclosed for maximum protection from weather, dust and corrosion. Access to the outdoor fan is made by removing four fasteners from the fan grille. The outdoor fan can be removed from the fan grille by removing 4 fasteners in the rare case outdoor fan motor fails.

Each cabinet has optimized composite (15) fan orifice assuring efficient and quiet airflow.



All cabinet painted parts have powder post paint (16) achieving 1000 hour salt spray rating, allowing the cabinet to retain its aesthetics throughout its life.

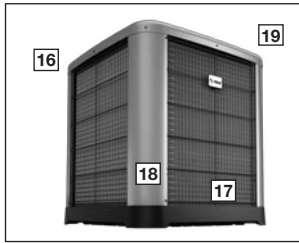

Scroll compressors with standard internal pressure relief and internal thermal overload are used on all capacities assuring longevity of high efficient and quiet operation for the life of the product.

Each unit is shipped with filter drier for field installation and will trap any moisture or dirt that could contaminate the refrigerant system.

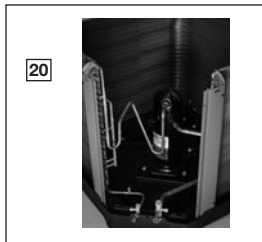

Cabinets are durable and strong due to the composite base pan (17), wire grille (18), and drawn top cover (19).

Each SA17 capacity has undergone rigorous psychometric testing to assure performance ratings of capacity, SEER and EER per AHRI Standard 210/240 rating conditions. Also each unit bears the UL mark and each unit is certified to UL 1995 safety standards.



Each unit has undergone specific strain and modal testing to assure tubing (20) is outside the units natural frequency and that the suction and discharge lines connected to the compressor withstand any starting, steady state operation or shut down forces imposed by the compressor.

All units have been sound tested in sound chamber to AHRI 270 rating conditions, and A-weighted Sound Power Level tables produced, assuring units have acceptable noise qualities (see page 9). Each unit has been ran in cooling operation at 95°F and 82°F and sound ratings for the SA17 range from as low as 74 dBA to 77 dBA.

All units have been ship tested to assure units meet stringent “over the road” shipping conditions.

As manufactured all units in the SA17 family have cooling capability to 55 °F. Addition of low ambient control will allow the unit to operate down to 0°F. Factory testing is performed on each unit. All component parts meet well defined specification and continually go through receiving inspections. Each component installed on a unit is scanned, assuring correct component utilization for a given unit capacity and voltage. All condenser coils are leak tested with pressurization test to 550#’s and once installed and assembled, each units’ complete refrigerant system is helium leak tested. All units are fully charged from the factory for up to 15 feet of piping. All units are factory run tested. The SA17 has a 10-year conditional compressor and parts warranty (registration required).

Optional Accessories

(Refer to accessory chart for model #)

Compressor Crankcase Heater

Protects against refrigerant migration that can occur during low ambient operation

Compressor Sound Cover

- Reinforced vinyl compressor cover containing a 1½ inch thick batt of fiberglass insulation
- Open edges are sealed with a one-inch wide hook and loop fastening tape

Compressor Hard Start Kit

- Single-phase units are equipped with a PSC compressor motor, this type of motor normally does not need a potential relay and start capacitor
- Kit may be required to increase the compressor starting torque, in conditions such as low voltage

Low Ambient Kit

- Air conditioners operate satisfactorily in the cooling mode down to 55°F outdoor air temperature without any additional controls
- This Kit can be added in the field enabling unit to operate properly down to 0° in the cooling mode
- Crankcase heater and freezestat should be installed on compressors equipped with a low ambient kit

Low Pressure

- Can be added in field enabling the unit to shut off compressor on loss of charge

NOTE: Unit can be purchased with high and low pressure installed at factory. (Refer to SKU list)

High Pressure

- Can be added in field enabling unit to shut off compressor if unit loses outdoor fan operation.

NOTE: Unit can be purchased with high and low pressure installed at factory. (Refer to SKU list)

Decorative Top

- Can be installed on fan grille

Air Conditioners*

<u>S</u>	<u>A</u>	<u>17</u>	<u>24</u>	<u>A</u>	<u>J</u>	<u>2</u>	<u>C</u>	<u>B</u>
Brand	Product Category	SEER	Capacity BTU/HR	Major Series*	Voltage	Type	Controls	Minor Series**
Russell™ By Rheem	A - Air Conditioners	17 - 17 SEER	24 - 24,000 [7.03 kW] 36 - 36,000 [10.55 kW] 48 - 48,000 [14.07 kW] 60 - 60,000 [17.58 kW]	A - 1st Design B - 2nd Design	J - 1ph, 208-230/60	2 - Two-stage	N - Non-Communicating	A - 1st Design B - High and low pressure control

*See page 3 for available SKUs.

Physical Data				
Model No.	SA1724	SA1736	SA1748	SA1760
Nominal Tonnage	2.0	3.0	4.0	5.0
Valve Connections				
Liquid Line O.D. – in.	3/8	3/8	3/8	3/8
Suction Line O.D. – in.	3/4	3/4	7/8	7/8
Refrigerant (R-410A) furnished oz. ¹	128	151	204	223
Compressor Type	Scroll			
Outdoor Coil				
Net face area – Outer Coil	19.8	22.2	32.3	32.3
Net face area – Inner Coil	—	—	—	—
Tube diameter – in.	0.375	0.375	0.375	0.375
Number of rows	1	1	1	1
Fins per inch	20	22	22	22
Outdoor Fan				
Diameter – in.	24	24	26	26
Number of blades	3	3	3	3
Motor hp	1/5	1/5	1/2	1/2
CFM	3326	3540	4251	5133
RPM	850	820	646	825
watts	112	112	132	113
Shipping weight – lbs.	200	209	297	298
Operating weight – lbs.	193	202	290	291
Electrical Data				
Line Voltage Data (Volts-Phase-Hz)	208/230-1-60	208/230-1-60	208/230-1-60	208/230-1-60
Maximum overcurrent protection (amps) ²	25	35	50	60
Minimum circuit ampacity ³	16	21	32	42
Compressor				
Rated load amps	11.7	15.3	21.2	28.8
Locked rotor amps	58.3	83	104	152.9
Condenser Fan Motor				
Full load amps	1.4	1.2	5.3	5.3
Locked rotor amps	—	—	—	—

¹Refrigerant charge sufficient for 15 ft. length of refrigerant lines. For longer line set requirements see the installation instructions for information about set length and additional refrigerant charge required.

²HACR type circuit breaker or fuse.

³Refer to National Electrical Code manual to determine wire, fuse and disconnect size requirements.

Accessories

Model No.		SA1724	SA1736	SA1748	SA1760
Compressor crankcase heater*		44-17402-44	44-17402-44	44-101884-05	44-101884-05
Low ambient control		RXAD-A08	RXAD-A08	RXAD-A08	RXAD-A08
Freeze Stat		50313	50313	50313	50313
Compressor sound cover		68-23427-26	68-23427-26	68-25217-10	68-25217-10
Compressor hard start kit		SK-A1	SK-A1	SK-A1	SK-A1
Liquid Line Solenoid (24 VAC, 50/60 Hz)	Solenoid Valve	200RD2T3TVLC	200RD2T3TVLC	200RD3T3TVLC	200RD3T3TVLC
	Solenoid Coil	61-AMG24V	61-AMG24V	61-AMG24V	61-AMG24V
Liquid Line Solenoid (120/240 VAC, 50/60 Hz)	Solenoid Valve	200RD2T3TVLC	200RD2T3TVLC	200RD3T3TVLC	200RD3T3TVLC
	Solenoid Coil	61-AMG120/240V	61-AMG120/240V	61-AMG120/240V	61-AMG120/240V

*Crankcase Heater recommended with Low Ambient Kit.

Weighted Sound Power Level (dBA)

Unit Size - Voltage, Series	Standard Rating (dBA)	TYPICAL OCTAVE BAND SPECTRUM (dBA without tone adjustment)						
		125	250	500	1000	2000	4000	8000
SA1724	72.5	48.6	53.7	62.9	63.0	60.5	57.3	54.6
SA1736	72.3	53.1	52.7	60.9	62.4	61.2	58.4	51.6
SA1748	73.0	46.1	50.4	59.5	64.6	59.6	55.8	54.6
SA1760	76.7	58.8	60.5	65.6	65.2	62.9	62.4	55.5

NOTE: Tested in accordance with AHRI Standard 270-08 (not listed in AHRI)

Unit Dimensions

MODEL NO.	OPERATING						SHIPPING					
	H (Height)		L (Length)		W (Width)		H (Height)		L (Length)		W (Width)	
	INCHES	mm	INCHES	mm	INCHES	mm	INCHES	mm	INCHES	mm	INCHES	mm
SA1724	35	889	33.75	857	33.75	857	36.75	933	36.38	924	36.38	924
SA1736	39	990	33.75	857	33.75	857	40.75	1035	36.38	924	36.38	924
SA1748	51	1295	35.75	908	35.75	908	52.75	1339	38.38	974	38.38	974
SA1760	51	1295	35.75	908	35.75	908	52.75	1339	38.38	974	38.38	974

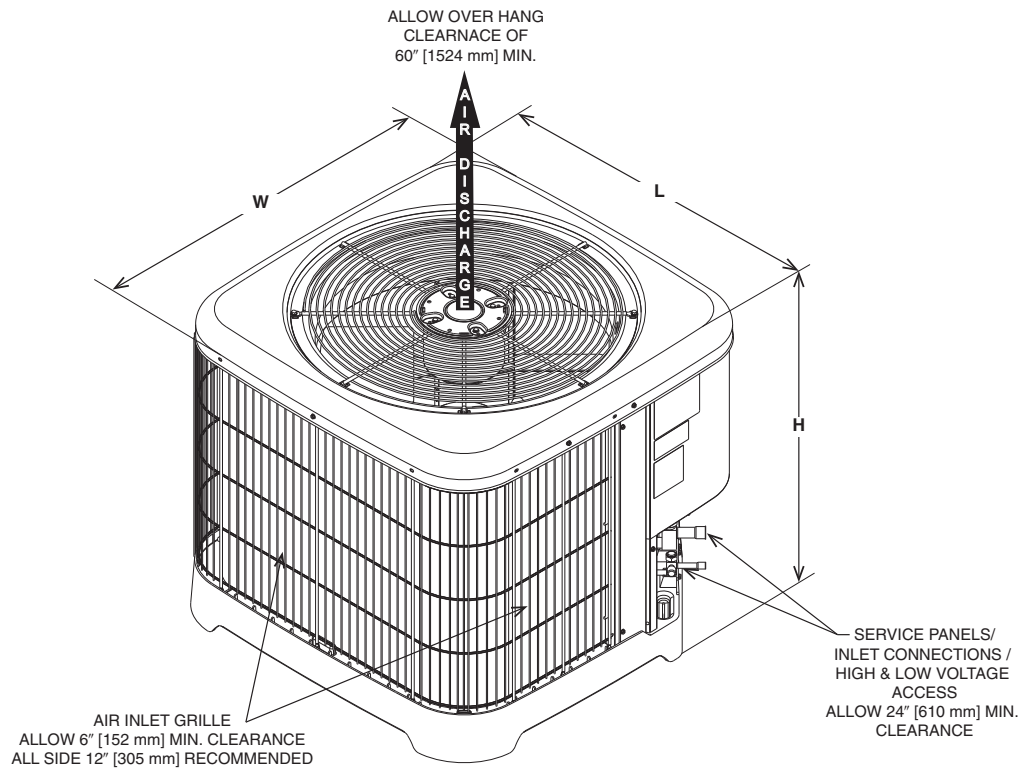

[] Designates Metric Conversions

ST-A1226-24-00

CLEARANCES

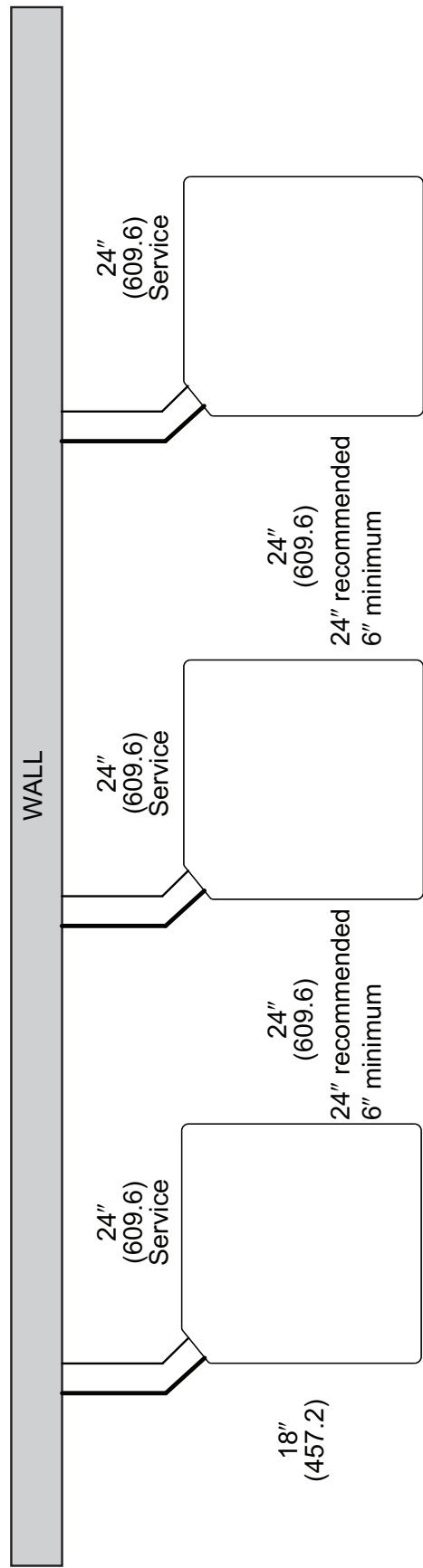
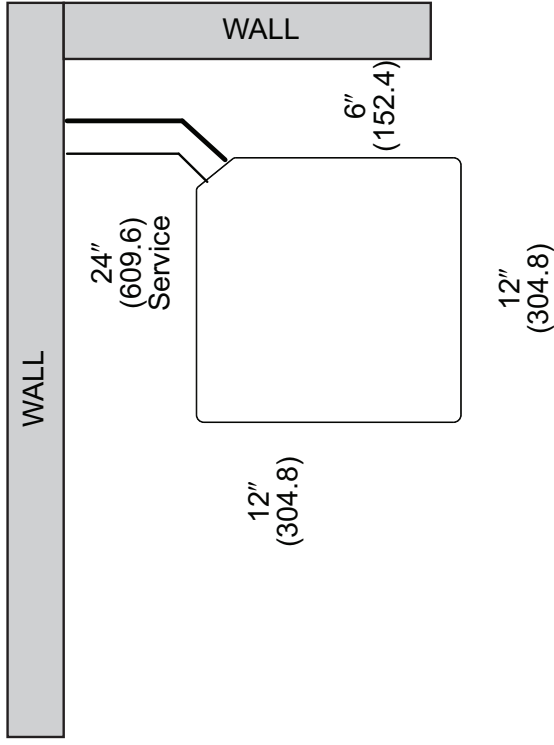
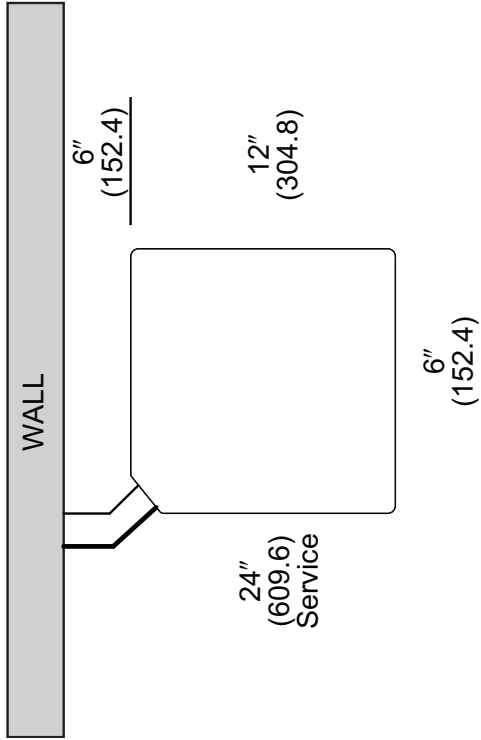

NOTE: NUMBERS IN () = mm

IMPORTANT: When installing multiple units in an alcove, roof well or partially enclosed area, ensure there is adequate ventilation to prevent re-circulation of discharge air.

Thermostat Wiring Diagrams

The following figures show the typical wiring diagrams with SH2T and (-)A17 outdoor units. Cooling and heat pump airflows may need to be adjusted for homeowner comfort once the system is operational.

WIRE COLOR CODE			
BK – BLACK	G – GREEN	PR – PURPLE	Y – YELLOW
BR – BROWN	GY – GRAY	R – RED	
BL – BLUE	O – ORANGE	W – WHITE	

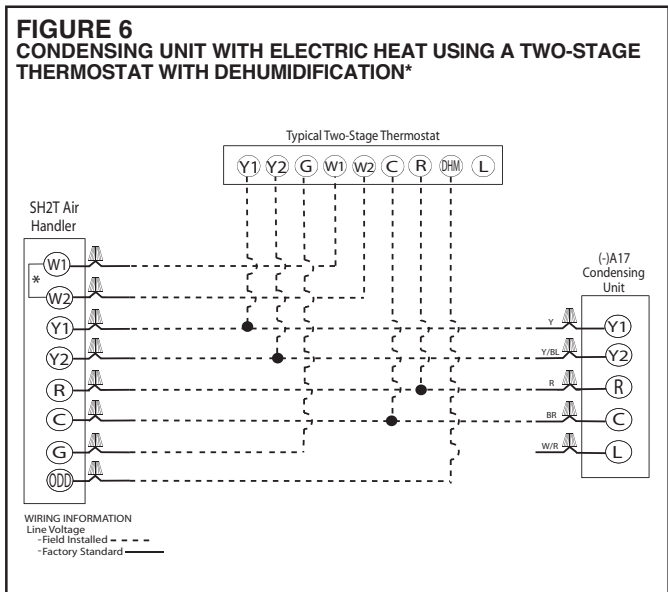
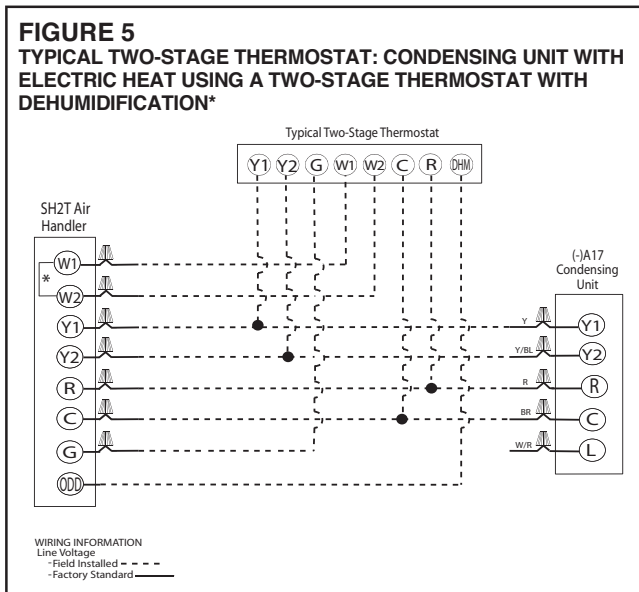
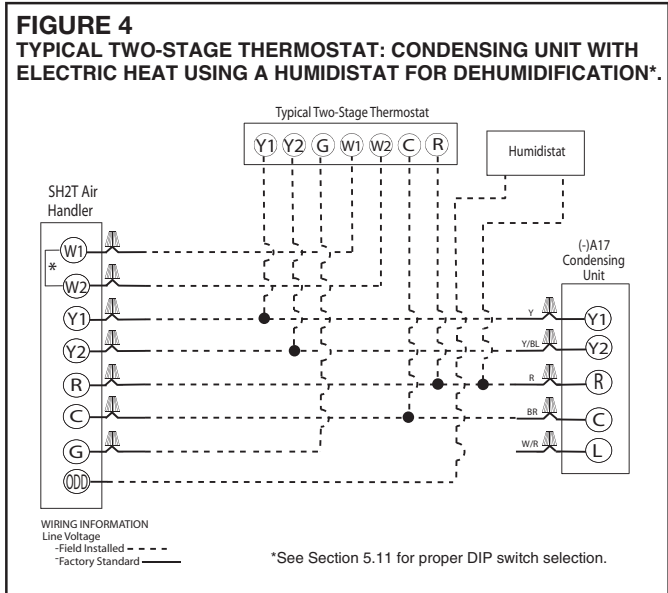
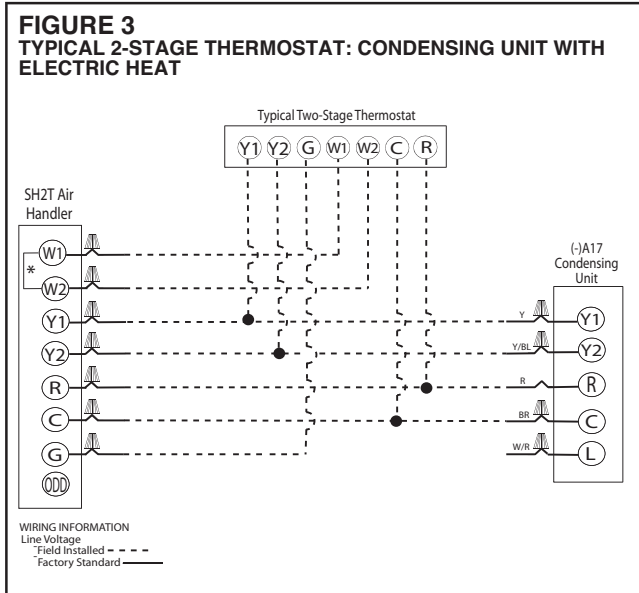

*If maximum outlet temperature rise is desired, it is recommended that W1 and W2 be jumpered together.

Application Guidelines

1. Intended for outdoor installation with free air inlet and outlet. Outdoor fan external static pressure available is less than 0.01 -in. wc.
2. Minimum outdoor operation air temperature for cooling mode without low-ambient operation accessory is 55°F (12.8°C).
3. Maximum outdoor operating air temperature is 125°F (51.7°C).
4. For reliable operation, unit should be level in all horizontal planes.
5. Use only copper wire for electric connections at unit. Aluminum and clad aluminum are not acceptable for the type of connector provided.
6. Do not apply capillary tube indoor coils to these units.
7. Factory – supplied filter drier must be installed.

Conventional Thermostat Wiring

Table 2A: Refrigerant Line Sizing Chart (English Units)

17 SEER 2-Stage Air-Conditioners									
Unit Size	Allowable Liquid Line Size	Allowable Vapor Line Size	Use Long Line Guidelines for Linear Line Lengths Greater Than Shown Below (Feet)	Outdoor Unit ABOVE or BELOW Indoor Unit Equivalent Length (Feet)					
				< 25	26-50	51-75	76-100	101-125	126-150
				Maximum Vertical Rise (Outdoor Unit Below Indoor Unit)* / Capacity Multiplier					
2.0 Ton *SEE NOTE 3	1/4"	5/8"	N/A	25/0.99	50/0.98	31/0.97	3/0.97	N/R	N/R
	5/16"	5/8"	73	25/0.99	50/0.98	50/0.97	50/0.97	50/0.96	50/0.95
	3/8"	5/8"	48	25/0.99	50/0.98	50/0.97	50/0.97	50/0.96	50/0.95
	1/4"	3/4**	N/A	25/1.00	50/1.00	31/0.99	3/0.99	N/R	N/R
	5/16"	3/4**	73	25/1.00	50/1.00	50/0.99	50/0.99	50/0.98	50/0.98
	3/8"	3/4**	48	25/1.00	50/1.00	50/0.99	50/0.99	50/0.98	50/0.98
3 Ton	5/16"	5/8"	20	25/0.99	50/0.97	50/0.95	50/0.93	34/0.91	N/R
	3/8"	5/8"	15	25/0.99	50/0.97	50/0.95	50/0.93	50/0.91	N/R
	5/16"	3/4"	20	25/1.00	50/0.99	50/0.99	50/0.98	34/0.97	18/0.96
	3/8"	3/4"	15	25/1.00	50/0.99	50/0.99	50/0.98	50/0.97	50/0.96
	1/2"	3/4"	0	25/1.00	50/0.99	50/0.99	50/0.98	50/0.97	50/0.96
4 Ton	3/8"	3/4"	0	25/0.99	50/0.98	50/0.97	50/0.95	50/0.94	50/0.93
	1/2"	3/4"	0	25/0.99	50/0.98	50/0.97	50/0.95	50/0.94	50/0.93
	3/8"	7/8"	0	25/1.00	50/0.99	50/0.99	50/0.98	50/0.98	50/0.97
	1/2"	7/8"	0	25/1.00	50/0.99	50/0.99	50/0.98	50/0.98	50/0.97
5 Ton	3/8"	3/4"	0	25/0.99	50/0.97	50/0.95	50/0.93	50/0.91	N/R
	1/2"	3/4"	0	25/0.99	50/0.97	50/0.95	50/0.93	50/0.91	N/R
	3/8"	7/8"	0	25/1.00	50/0.99	50/0.98	50/0.98	50/0.97	39/0.96
	1/2"	7/8"	0	25/1.00	50/0.99	50/0.98	50/0.98	50/0.97	50/0.96

NOTES:

- 1) Do not exceed 150 ft linear line length.
- 2) Do not exceed 50 ft vertical separation between indoor and outdoor units.
- 3) * 3/4" vapor line should only be used for 2 ton systems if outdoor unit is below or at same level as indoor unit to assure proper oil return.
- 4) Always use the smallest liquid line allowable to minimize refrigerant charge.
- 5) Applications shaded in light gray indicate capacity multipliers between 0.90 and 0.96 which are not recommended, but are allowed.
- 6) Applications shaded in dark gray are not recommended due to excessive liquid or suction pressure drop.

[] Designates Metric Conversions

Table 2B: Refrigerant Line Sizing Chart (Metric Units)

17 SEER 2-Stage Air-Conditioners									
Unit Size	Allowable Liquid Line Size mm [in.]	Allowable Vapor Line Size mm [in.]	Use Long Line Guidelines for Linear Line Lengths Greater Than Shown Below (Meters)	Outdoor Unit ABOVE or BELOW Indoor Unit Equivalent Length (Feet)					
				< 8	8-15	16-23	24-30	31-38	39-46
				Maximum Vertical Rise (Outdoor Unit Below Indoor Unit)* / Capacity Multiplier					
7.0 kW [2.0 Ton] *SEE NOTE 3	6.35 [1/4]	15.88 [5/8]	N/A	8/0.99	15/0.98	9/0.97	1/0.97	N/R	N/R
	7.94 [5/16]	15.88 [5/8]	22	8/0.99	15/0.98	15/0.97	15/0.97	15/0.96	15/0.95
	9.53 [3/8]	15.88 [5/8]	15	8/0.99	15/0.99	15/0.97	15/0.97	15/0.96	15/0.95
	6.35 [1/4]	19.05 [3/4]*	N/A	8/1.00	15/0.99	9/0.99	1/0.99	N/R	N/R
	7.94 [5/16]	19.05 [3/4]*	22	8/1.00	15/0.99	15/0.99	15/0.99	15/0.98	15/0.98
	9.53 [3/8]	19.05 [3/4]*	15	8/1.00	15/0.99	15/0.99	15/0.99	15/0.98	15/0.98
10.6 kW [3 Ton]	7.94 [5/16]	15.88 [5/8]	6	8/0.99	15/0.97	15/0.95	15/0.93	10/0.91	N/R
	9.53 [3/8]	15.88 [5/8]	5	8/0.99	15/0.97	15/0.95	15/0.93	15/0.91	N/R
	7.94 [5/16]	19.05 [3/4]	6	8/1.00	15/0.99	15/0.99	15/0.98	10/0.97	5/0.96
	9.53 [3/8]	19.05 [3/4]	5	8/1.00	15/0.99	15/0.99	15/0.98	15/0.97	15/0.96
	12.7 [1/2]	19.05 [3/4]	0	8/1.00	15/0.99	15/0.99	15/0.98	15/0.97	15/0.96
14.1 kW [4 Ton]	9.53 [3/8]	19.05 [3/4]	0	8/0.99	15/0.98	15/0.97	15/0.95	15/0.94	15/0.93
	12.7 [1/2]	19.05 [3/4]	0	8/0.99	15/0.98	15/0.97	15/0.95	15/0.94	15/0.93
	9.53 [3/8]	22.23 [7/8]	0	8/1.00	15/0.99	15/0.99	15/0.98	15/0.98	15/0.97
	12.7 [1/2]	22.23 [7/8]	0	8/1.00	15/0.99	15/0.99	15/0.98	15/0.98	15/0.97
17.6 kW [5 Ton]	9.53 [3/8]	19.05 [3/4]	0	8/0.99	15/0.97	15/0.95	15/0.93	15/0.91	N/R
	12.7 [1/2]	19.05 [3/4]	0	8/0.99	15/0.97	15/0.95	15/0.93	15/0.91	N/R
	9.53 [3/8]	22.23 [7/8]	0	8/1.00	15/0.99	15/0.98	15/0.98	15/0.97	12/0.96
	12.7 [1/2]	22.23 [7/8]	0	8/1.00	15/0.99	15/0.98	15/0.98	15/0.97	15/0.96

NOTES:

- 1) Do not exceed 46 meters linear line length.
- 2) Do not exceed 15 meters vertical separation between indoor and outdoor units.
- 3) * 19.05mm [3/4 in.] vapor line should only be used for 2 ton systems if outdoor unit is below or at same level as indoor unit to assure proper oil return.
- 4) Always use the smallest liquid line allowable to minimize refrigerant charge.
- 5) Applications shaded in light gray indicate capacity multipliers between 0.90 and 0.96 which are not recommended, but are allowed.
- 6) Applications shaded in dark gray are not recommended due to excessive liquid or suction pressure drop.

[] Designates Metric Conversions

Performance Data @ AHRI Standard Conditions – Cooling

Designated Tested Combination (DTC)							
Outdoor Unit	Indoor Coil	Total Capacity BTU/H [kW]	Net Sensible BTU/H [kW]	Net Latent BTU/H [kW]	SEER	EER	Indoor CFM [L/s]
SA1724AJ2	TCF2417STA	24000 [7.0]	18000 [5.3]	6000 [1.8]	14.00	12.20	800 [377.6]
SA1736AJ2	TCF3621MTA	34800 [10.2]	26000 [7.6]	8800 [2.6]	14.00	12.20	1050 [495.5]
SA1748AJ2	TCF4821MTA	46000 [13.5]	34400 [10.1]	11600 [3.4]	14.00	11.70	1450 [684.3]
SA1760AJ2	TCF6024STA	55500 [16.3]	41700 [12.2]	13800 [4.0]	14.00	11.70	1575 [743.3]

Air Handler							
Outdoor Unit	Indoor Coil	Total Capacity BTU/H [kW]	Net Sensible BTU/H [kW]	Net Latent BTU/H [kW]	SEER	EER	Indoor CFM [L/s]
SA1724AJ2	SH2T2421MEAC	24000 [7.0]	18000 [5.3]	6000 [1.8]	17.0	13.0	525 [495.5]
SA1736AJ2	SH2T3621MEAC	34800 [10.2]	26000 [7.6]	8800 [2.6]	17.0	13.0	800 [377.6]
SA1748AJ2	SH2T4821MEAC	47000 [13.7]	34400 [10.1]	11600 [3.4]	17.0	13.0	1150 [542.7]
SA1760AJ2	SH2T6024MEAC	56000 [16.4]	41700 [12.2]	13800 [4.0]	16.0	12.5	1175 [554.5]

Note: Additional ratings and system match ups can be accessed on My.RussellByRheem.com at: <https://my.RussellByRheem.com/static/private/ahriresidential.html>
 Additional ratings and system match ups and downloadable ratings certificates can be accessed from the AHRI website: www.ahridirectory.org

[] Designates Metric Conversions

GUIDE SPECIFICATIONS

General

System Description

Outdoor-mounted, air-cooled, split-system air conditioner composite base pan unit suitable for ground or rooftop installation. Unit consists of a hermetic compressor, an air-cooled coil, propeller-type condenser fan, suction and legend line service valve, and a control box. Unit will discharge supply air upward as shown on contract drawings. Unit will be used in a refrigeration circuit to match up to a coil unit.

Quality Assurance

- Unit will be rated in accordance with the latest edition of AHRI Standard 210.
- Unit will be certified for capacity and efficiency, and listed in the latest AHRI directory.
- Unit construction will comply with latest edition of ANSI/ASHRAE and with NEC.
- Unit will be constructed in accordance with UL standards and will carry the UL label of approval. Unit will have c-UL-us approval.
- Unit cabinet will be capable of withstanding ASTM B117 1000-hr salt spray test.
- Air-cooled condenser coils will be leak tested at 150 psig and pressure tested at 550 psig.
- Unit constructed in ISO9001 approved facility.

Delivery, Storage, and Handling

- Unit will be shipped as single package only and is stored and handled per unit manufacturer's recommendations.

Warranty (for inclusion by specifying engineer) – U.S. and Canada only.

Products

Equipment

Factory assembled, single piece, air-cooled air conditioner unit. Contained within the unit enclosure is all factory wiring, piping, controls, compressor, refrigerant charge R-410A, and special features required prior to field start-up.

Unit Cabinet

- Unit cabinet will be constructed of galvanized steel, bonderized, and coated with a powder coat paint.
- All units constructed with louver coil protection and corner post. Louver can be removed by removing one fastener per louver panel.

AIR-COOLED, SPLIT-SYSTEM AIR CONDITIONER SA17

2 TO 5 NOMINAL TONS

Fans

- Condenser fan will be direct-drive propeller type, discharging air upward.
- Condenser fan motors will be totally enclosed, 1-phase type with class B insulation and permanently lubricated bearings. Shafts will be corrosion resistant.
- Fan blades will be statically and dynamically balanced.
- Condenser fan openings will be equipped with coated steel wire safety guards.

Compressor

- Compressor will be hermetically sealed.
- Compressor will be mounted on rubber vibration isolators.

Condenser Coil

- Condenser coil will be air cooled.
- Coil will be constructed of aluminum fins mechanically bonded to copper tubes.

Refrigeration Components

- Refrigeration circuit components will include liquid-line shutoff valve with sweat connections, vapor-line shutoff valve with sweat connections, system charge of R-410A refrigerant, and compressor oil.
- Unit will be equipped with filter drier for R-410A refrigerant for field installation.

Operating Characteristics

- The capacity of the unit will meet or exceed _____ Btuh at a suction temperature of _____ °F/°C. The power consumption at full load will not exceed _____ kW.
- Combination of the unit and the evaporator or fan coil unit will have a total net cooling capacity of _____ Btuh or greater at conditions of _____ CFM entering air temperature at the evaporator at _____ °F/°C wet bulb and _____ °F/°C dry bulb, and air entering the unit at _____ °F/°C.
- The system will have a SEER of _____ Btuh/watt or greater at DOE conditions.

Electrical Requirements

- Nominal unit electrical characteristics will be _____ v, single phase, 60 hz. The unit will be capable of satisfactory operation within voltage limits of _____ v to _____ v.
- Nominal unit electrical characteristics will be _____ v, three phase, 60 hz. The unit will be capable of satisfactory operation within voltage limits of _____ v to _____ v.
- Unit electrical power will be single point connection.
- Control circuit will be 24v.

Special Features

- Refer to section of this literature identifying accessories and descriptions for specific features and available enhancements.

GENERAL TERMS OF LIMITED WARRANTY*

Rheem® will furnish a replacement for any part of this product which fails in normal use and service within the applicable period stated, in accordance with the terms of the limited warranty.

***For complete details of the Limited and Conditional Warranties, including applicable terms and conditions, contact your local contractor or the Manufacturer for a copy of the product warranty certificate.**

Conditional Unit Replacement
(Registration Required) Ten (10) Years
Parts Ten (10) Years



Russell™ By Rheem

5600 Old Greenwood Road, Fort Smith, AR 72908

Before proceeding with installation, refer to installation instructions packaged with each model, as well as complying with all Federal, State, Provincial, and Local codes, regulations, and practices.

PRINTED IN U.S.A. 3/20 QG FORM NO. ARR-226