



engineered for life™

Packaged Gas Electric
RGEHYB360 Series

Commercial Resolute™ Line Classic® Series Packaged Gas Electric Units



RGEHYB360 Series (30 Ton Models)

Cooling Efficiencies up to: 9.8 EER & 13.0 IEER

Nominal Sizes: 30 Tons [105.5 kW]

Cooling Capacity: 330k Btu/h [96.71 kW]

Refrigerant Type: R-454B

ASHRAE 90.1 2022 Compliant Models



TABLE OF CONTENTS

Unit Features & Benefits	3-10
Model Number Identification	11
Options	12
Selection Procedure	13
General Data / Notes	14
General Data Notes	15
Gross Systems Performance Data	16
Heating Performance Data	17
Indoor Airflow Performance	18-21
Electrical Data.....	22-23
A2L Installation Safety Data	24
Dimensional Data	25-28
Accessories	29-42
Mechanical Specifications	43-50
Limited Warranty	51



RGEH STANDARD FEATURES INCLUDE:

Manufacturing / Quality Features

- Factory charged with R-454 refrigerant
- Wired and run tested at the factory
- Powder Paint Finish meets ASTM® B117 test requirements. G90 galvanized steel coated on each side for maximum protection
- Foil faced insulation encapsulated throughout entire unit minimizes airborne fibers in the air stream

Performance Features

- Cooling operation up to 125°F ambient
- Scroll compressors with internal line break overload and high-pressure protection
- One single-stage and one two-stage compressor for 5 total stages of cooling
- MicroChannel condenser coil and Tube and Fin evaporator coil
- Blower with variable frequency drive (VFD) control
- Single- and multi-zone variable air volume (VAV) capable
- High pressure and low pressure/loss of charge protection
- Permanently lubricated gas heat inducer, evaporator and condenser motors
- Internally protected condenser motors with totally enclosed shaft down design

Convenience/Serviceability Features

- Fork-able base rails for easy handling and lifting
- Color-coded and labeled wiring
- Single point electrical connections
- Field convertible airflow—vertical downflow or horizontal sideflow
- Solid-core liquid line filter drier
- Hinged major access doors with heavy-duty gasketing and 1/4 turn latches
- Slide-out indoor fan assembly for added service convenience
- Slide-out, internally sloped condensate drain pan with overflow switch, conforms to ASHRAE 62 standards
- Slide-out filter rack with 2-inch filters
- MERV8 and MERV13 filters available as a factory-installed option
- Factory-installed refrigerant leak detection system

Controls Features

- Standard Modbus® interface
- Factory-installed DDC control and sensors, enabling easy connectivity with LonWorks® or BACnet® BAS systems for remote monitoring and control

FACTORY-INSTALLED OPTIONS:

- Louvered panels
- Hinged access doors
- Low-Ambient Control Kit
- Freeze Stat Kit
- Economizer w/Single Enthalpy (Downflow/Vertical)
- Economizer w/Single Enthalpy (Downflow/Vertical) DDC
- Comfort Alert®/Phase monitor
- Disconnect Switch

FIELD-INSTALLED ACCESSORY EQUIPMENT:

Accessory	Model Number	Factory Installation Available?
Economizers		
DDC Economizer with Single Enthalpy (Downflow) <i>RRS Economizer with Honeywell® Controller</i>	AXRD-01RMDCM3	Yes
DDC Economizer with Single Enthalpy (Downflow) <i>RRS Economizer with Honeywell Controller with Smoke Detector</i>	AXRD-01RMDDM3	Yes
DDC Economizer with Single Enthalpy (Horizontal) <i>RRS Economizer with Honeywell Controller</i>	AXRD-01RMHCM3	No
Non-DDC Economizer with Single Enthalpy (Downflow) <i>RRS Economizer with Siemens® Controller</i>	RXRD-51RHDAM3	Yes
Non-DDC Economizer with Single Enthalpy (Horizontal) <i>RRS Economizer with Siemens Controller</i>	RXRD-51RHHAM3	No
Economizer Universal DDC Interface Kit	RXXR-DDC02	Yes

Accessory	Model Number	Factory Installation Available?
Comfort Alert (1 per Compressor)	RXXR-AZ01	Yes
Communication Card, BACnet	RXXR-AY01	No
Communication Card, LonWorks	RXXR-AY02	No
Concentric Adapter/Transition	RXMC-CL09	No
Concentric Step Down Diffuser	RXRN-AD88	No
Convenience Outlet, Non-Powered	RXXR-AN01	Yes
Dual Enthalpy, Temperature and Humidity Sensor (for Honeywell DDC)	RXXR-AV02	No
Dual Enthalpy, Temperature and Humidity Sensor (for Siemens Controller)	PD555460	No
Fresh Air Damper ¹ , Manual	AXRF-KFA1	No
Outdoor Coil Louver Kit	AXRX-AAD01L	Yes
Low-Ambient Control Kit (1 Per Compressor)	RXRZ-C02	Yes

Accessory	Model Number	Factory Installation Available?
MERV 8 Filter	RXMF-M08A22520	Yes
MERV 13 Filter	RXMF-M13A22520	Yes
Power Exhaust (208/230V) Kit, Convertible <i>RRS</i>	RXXR-BGF05C	No
Power Exhaust (460V) Kit, Convertible <i>RRS</i>	RXXR-BGF05D	No
Roofcurb, 14"	RXKG-CBH14	No
Roofcurb Adapter to RXKG-CAF14	RXXR-CJCF14	No
Roofcurb Adapter to RXRK-E56	RXXR-CJCE56	No
Sensor, Carbon Dioxide (Wall Mount)	RXXR-AR02	No
Sensor, Room Humidity	RHC-ZNS4	No
Sensor, Room Temperature and Relative Humidity	RHC-ZNS5	No
Unfused Service Disconnect	RXXR-AP01	Yes

¹Motorized Kit and Manual Fresh Air Damper must be combined for a complete Motorized Outside Air Damper Selection

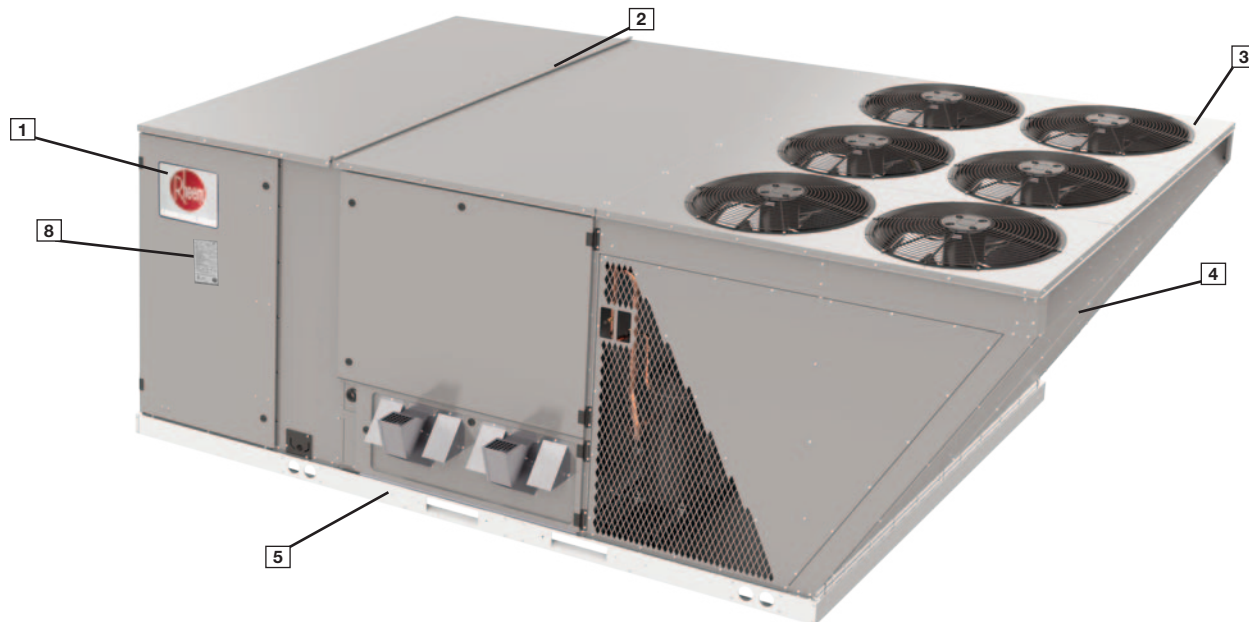

Cabinet and Foundation

Resolute™ packaged equipment is design from the ground up with the latest features and benefits required to compete in today's market. The clean design stands alone in the industry and is a testament to the quality, reliability, ease of installation and serviceability that goes into each unit. Outwardly, the Rheem label (1) identifies the brand to the customer.

The sheet metal cabinet (2) uses nothing less than 20-gauge material for structural components with an underlying coat of G90. To ensure the leak-proof integrity of these units, the design utilizes a top with a 1/8" drip lip (3), gasket-protected panels and screws. The slanted outdoor coil protects the coil from hail damage (4). Every Rheem packaged unit uses the toughest finish in the industry, using electro deposition baked-on enamel tested to withstand a rigorous 1000-hour salt spray test, per ASTM B117.

Base Pan and Foundation

Anything built to last must start with the right foundation. In this case, the foundation is a 14-gauge, commercial-grade, full-perimeter base rails (5), which integrate fork slots and rigging holes to save set-up time on the job site. The base pan is stamped, which forms a 1-1/8" flange around the supply and return opening and has eliminated the worry of water entering the conditioned space (6).

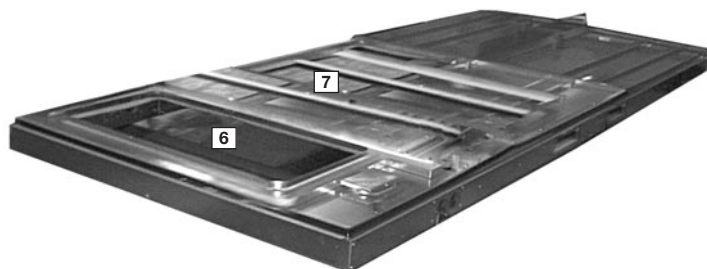

Drain Pan

The drain pan (7) is made of plastic that resists the growth of harmful bacteria and drain pan is sloped for the latest IAQ benefits. Furthermore, the drain pan slides out for easy cleaning. The insulation has been placed on the underside of the base pan, removing areas that would allow for potential moisture accumulation, which can facilitate growth of harmful bacteria. All insulation is secured with both adhesive and mechanical fasteners, and all edges are hidden.

Test Standards

During development, each unit was tested to UL 60335-2-40, ANSI 21.47, AHRI 340/360 and other Rheem-required reliability tests. Rheem adheres to stringent ISO 9001:2015 quality procedures, and each unit bears the U.L. and AHRI certification labels located on the unit nameplate (8). Contractors can rest assured that when a Rheem packaged unit arrives at the job, it is ready to go with a factory charge and quality checks.

Easy Access

Access all major compartments from the front of the unit, including the filter and electrical compartment, blower compartment, heating section, and outdoor section. Each panel is permanently embossed with the compartment name (control/filter access, blower access, and furnace access).

Electrical and filter compartment access is through a large, toolless, hinged-access panel with 1/4 turn latches. On the outside of the panel is the unit nameplate, which contains the model and serial number, electrical data, and other important unit information.

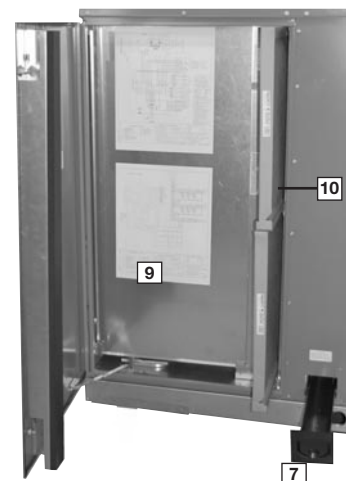

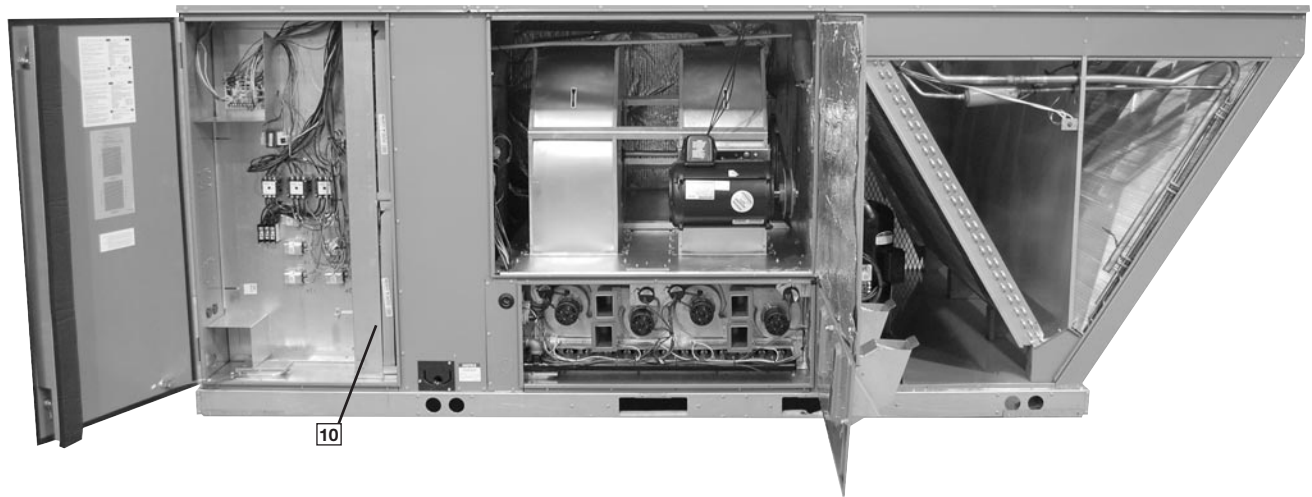

Charging Charts, Wiring Diagrams, & Labels

The unit charging chart is located on the inside of the electrical and filter compartment door. Electrical wiring diagrams are found on the control box cover, which allows contractors to move them to more readable locations. To the right of the control box, the model and serial number can be found. Having this information on the inside will assure model identification for the life of the product. The production line quality test assurance label is also placed in this location (9).

Filter Rack

The two-inch throwaway filters (10) are easily removed on a slide-out tracked system for easy replacement.



Blower Assembly

The blower compartment is to the right of the control box and can be accessed by 1/4 turn latches. To allow easy maintenance of the blower assembly, the entire assembly easily slides out by removing four #10 screws from the blower assembly. The adjustable motor pulley (11) can easily be adjusted by loosening the bolts on either side of the motor mount. Removing the bolts allows for easy removal of the blower pulley by pushing the blower assembly up to loosen the belt. Once the belt is removed, the motor sheave can be adjusted to the desired number of turns, ranging from 1 to 6 turns open.

Where the demands for the job require high static, Rheem has high-static drives available that deliver nominal airflow up to 2" of static. By referring to the airflow performance tables listed in the

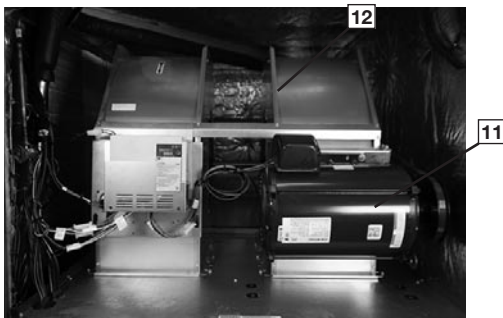

installation instruction, proper static pressure and CFM requirements can be dialed in. The scroll housing (12) and blower scroll provide quiet and efficient airflow. The blower sheave is secured by an "H" bushing which firmly secures the pulley to the blower shaft for years of trouble-free operation. The "H" bushing allows for easy removal of the blower pulley from the shaft, creating burrs that make blower-pulley removal difficult.

High and Low Pressure Switches & Freeze Stat

The low-pressure switches and high-pressure switches are mounted on the appropriate refrigerant lines in the condenser section. The high-pressure switch will shut off the compressors if pressures exceeding 610 PSIG are detected as may occur if the outdoor fan motor fails. The low-pressure switches shut off the compressors if low pressure is detected due to loss of refrigerant charge. Each factory-installed option is brazed into the appropriate high or low side and wired appropriately. Use of polarized plugs allow for easy field inspection and repair.

Thermostatic Expansion Valve (TXV)

Inside the blower compartment the interlaced evaporator can also be viewed. The evaporator uses fin technology for maximum heat transfer. The TXV (13) metering device assures even distribution of refrigerant throughout the evaporator.



Control Box

Inside the control box (14), each electrical component is clearly identified with a label that matches the component to the wire diagram for ease of trouble shooting. Most of the wiring is numbered on each end of the termination and color-coded to match the wiring diagram. The integrated furnace control, used to control furnace operation, incorporated a flashing LED troubleshooting device. Flash codes are clearly outlined on the unit wiring diagram. The control transformer has a low voltage circuit breaker that trips if a low voltage electrical short occurs. There is also a compressor contactor for each compressor.



Convenience Outlet & Service Disconnect

For added convenience in the field, a factory-installed service disconnect switch and convenience outlet (15) are available. Low and High voltage can enter either from the side or through the base. Low-voltage connections are made through the low-voltage terminal strip. For ease of access, the U.L.-required low voltage barrier can be temporarily removed for low-voltage termination and then reinstalled. The high-voltage connection is terminated at the high-voltage terminal block. The suggested mounting for the field-installed disconnect is on the exterior side of the electrical control box.



External Gauge Ports

The high (16) and low (17) external gauge ports are located in the outdoor section. With gauge ports mounted externally, an accurate diagnostic of system operation can be performed quickly and without removing exterior panels.



ClearControl

As part of the ClearControl system (18) which allows real time monitoring and communication between rooftop units, the RGEH Packaged AC Unit has a Rooftop Unit Controller (RTU-C) factory mounted and wired in the control panel. The RTU-C is a solid-



state microprocessor-based control board that provides flexible control and extensive diagnostics for all unit functions. The RTU-C through proportional/integral control algorithms perform specific unit functions that govern unit operation in response to: zone conditions, system temperatures, system pressures, ambient conditions, and electrical inputs. The RTU-C features a 16 x 2 character LCD display and a five-button keypad for local configuration and direct diagnosis of the system. Features include a clogged filter switch (CFS), fan proving switch (FPS), return air temperature sensor (RAT), discharge air temperature sensor (DAT), and outdoor air temperature sensor (OAT). Freeze sensors (FS) are used in place of freezestats to allow measurement of refrigerant suction line temperatures.

The RGEH with the RTU-C is specifically designed to be applied in four distinct applications:

- 1. BACnet Communication** — The RGEH is compatible with a third party building management system that supports the BACnet Application Specific Controller device profile, with the use of a field-installed BACnet Communication Module. The BACnet Communication Module plugs into the unit RTU-C controller and allows communication between ClearControl and the BACnet MSTP or IP network. A zone sensor, a BACnet network zone sensor, a BACnet thermostat or DDC controller may be used to send the zone thermostat or thermostat demands to the RTU-C. The BACnet Communication Module is compatible with MSTP EIA-485 daisy chain networks communicating at 38.4 bps. It is compatible with twisted pair, shielded cables.
- 2. LonWorks Communication** — The RGEH is compatible with a third party building management system that supports the LonMark Space Comfort Controller (SCC) functional profile or LonMark Discharge Air Controller (DAC) functional profile. This is accomplished with a field-installed LonMark communication module. The LonMark Communication Module plugs onto the RTU-C controller and allows communication between ClearControl™ and a LonWorks network. A zone sensor, a LonTalk network zone sensor, or a LonTalk thermostat or DDC controller may be used to send the zone temperature or thermostat demands to the RTU-C. The LonMark Communication Module utilizes an FTT-10A free topology transceiver communicating at 78.8 kbps. It is compatible with Echelon qualified, twisted pair cable, Belden 8471, or NEMA Level 4 cables. The module can communicate up to 1640 feet with no repeater. The LonWorks limit of 64 nodes per segment applies to this device.
- 3. 24V Thermostat Compatibility** — The RGEH is compatible with a programmable 24 volt thermostat. Connections are made via conventional thermostat screw terminals. Extensive unit status and diagnostics are displayed on the LCD screen of the RTU-C.
- 4. Zone Sensor Compatibility** — The RGEH is compatible with a zone sensor and a mechanical or solid state time clock connected to the RTU-C. Extensive unit status and diagnostics are displayed on the LCD screen of the RTU-C.

Comfort Alert

A factory or field-installed Comfort Alert module is available for power phase-monitoring protection and additional compressor diagnostics. The alarms can be displayed on the RTU-C display, through the (BAS) network, or connected to the “L-Terminal” of a thermostat for notification. Wiring throughout the unit is neatly bundled and routed. Where wire harnesses go through the condenser bulkhead or blower deck, a molded wire harness assembly (19) provides an air-tight and water-tight seal, and provides strain relief. Care is also taken to tuck raw edges of insulation behind sheet metal to improve indoor air quality.

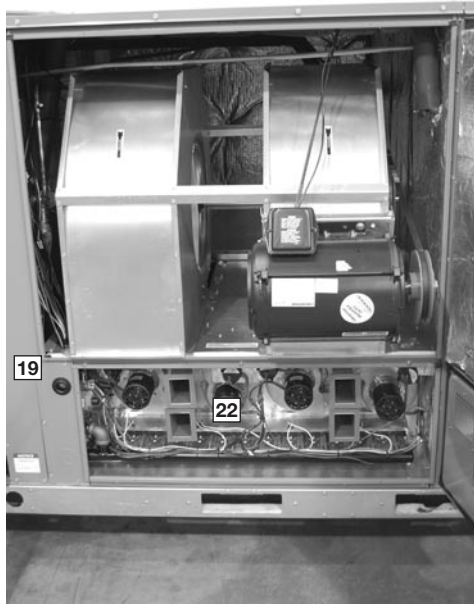

Furnace & Gas Heat Exchanger

The furnace compartment contains the latest furnace technology on the market. The draft inducers (20) draw the flame from the Rheem exclusive in-shot burners (21) into the aluminized tubular heat exchanger (22) for clean, efficient gas heat. Stainless steel heat exchangers can be factory installed for those applications that have high fresh-air requirements, or applications in corrosive environments. Each furnace is equipped with a two-stage gas valve (23), which provides two stages of gas heat input. The first stage operates at 50% of the second stage (full fire). 81% steady state efficiency is maintained on both first and second stage by staging the multiple inducers to optimize the combustion airflow and maintain a near stoichiometric burn at each stage.

The direct spark igniter (24) ensures reliable ignition in the most adverse conditions. This is coupled with remote flame sensor (25) to ensure that the flame has carried across the entire length of the burner assembly. Gas supply can be routed from the side or up through the base.

Each furnace has the following safety devices to ensure consistent and reliable operation after ignition:

- Pressures switches (26) to ensure adequate combustion airflow before ignition.
- Rollout switches (27) to ensure no obstruction or cracks in the heat exchanger.
- A limit device that protects the furnace from over-temperature problems.

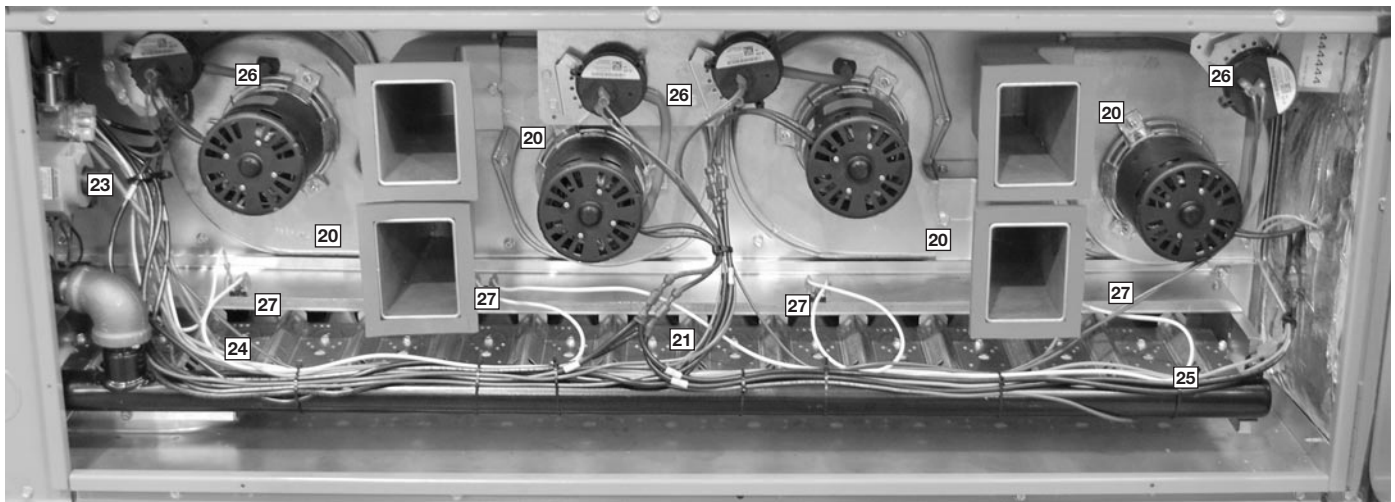

Compressor

The compressor compartment houses the heartbeat of the unit. The scroll compressors (28) are known for their long life and for reliable, quiet, and efficient operation. Each compressor has four rubber grommets (27) on the bottom for sound and vibration dampening. The suction and discharge lines are designed with shock loops to absorb the strain and stress that the starting torque, steady state operation, and shut down cycle impose on the refrigerant tubing. Each compressor and circuit are independent for built-in redundancy, and each circuit is clearly marked throughout the system. Each unit has 5 stages of cooling for precise supply air control.



Condenser Fans

The condenser fan motors (29) can easily be accessed and maintained through the top of the unit. A down-mount fan provides corrosion protection and easy removal. The polarized plug connection allows the motor to be changed quickly and eliminated the need to snake wires through the unit.

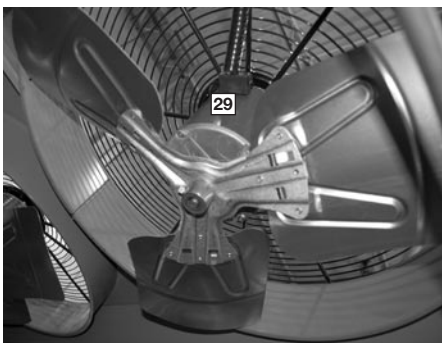

MicroChannel Condenser Technology

The outdoor coil uses the latest MicroChannel (30) technology for the most effective method of heat transfer. The outdoor coil is protected by optional louvered panels, which allow unobstructed airflow while protecting from both the environment and vandalism.

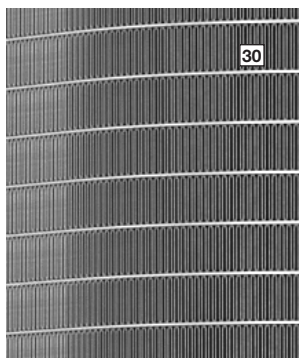

Economizers and Dampers

Each unit is designed for both downflow or horizontal applications for job configuration flexibility. The return air compartment can also contain an economizer. Two models exist: one for downflow applications, and one for horizontal applications. Each unit is pre-wired for the economizer to allow quick plug-in installation. The downflow economizer is also available as a factory-installed option. Power Exhaust is easily field-installed.

The economizer, which provides free cooling when outdoor conditions are suitable and also provides fresh air to meet local requirements, come standard with single enthalpy controls. The controls can be upgraded to dual enthalpy easily in the field. The direct drive actuator combined with gear drive dampers has eliminated the need for linkage adjustment in the field. The economizer control has a minimum position set-point, an outdoor-air set-point, a mix-air set-point, and a CO₂ set-point.

Barometric relief is standard on all economizers. The power exhaust is housed in the barometric relief opening and is easily slipped in with a plug-in assembly.

Roofcurb

The roofcurb (31) is made for toolless assembly at the jobsite by inserting a pin into a hinge in each corner of the adjacent curb sides (32), which makes the assembly process quick and easy.

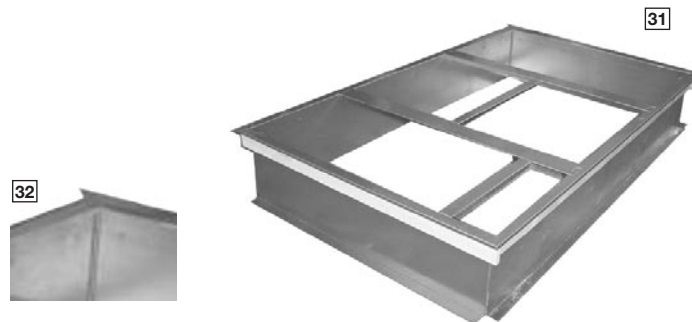

31

32

Variable Frequency Drive

The supply fan Variable Frequency Drive (VFD) (33) optimizes energy usage year round by providing a lower speed for first stage cooling operation, improving IEER's over the conventional constant fan system. Operating in the constant fan mode at the reduced speed can use as little as 1/5 of the energy of a conventional constant fan system. Also, by operating at a lower speed on first stage cooling, up to 51% more moisture is removed, improving comfort during low load operation. The VFD supply fan meets California Title 24 and ASHRAE 90.1 requirements for multi blower speed control. VFD also ramps up to the desired speed, reducing stress on the supply fan components and noise from a sudden inrush of air. Because the airflow is cut in half during first stage cooling and constant fan operation, noise is much less during these modes of operation.

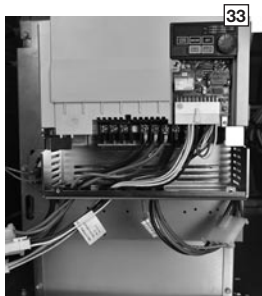

Variable Air Volume (VAV)

Single and Multi-Zone Variable Air Volume (VAV) allows for enhanced control of airflow and temperature in multiple building zones. The VAV technology is compatible with industry standard zoning controls and zone systems. The controls vary the airflow and the cooling capacity to meet the demands of multiple zones. This increases the comfort and air quality of the environment.

Refrigerant Leak Detection

In the event of a detected refrigerant leak, the refrigerant leak detection sensor(s) (34) will trigger the mitigation procedure that shuts off the compressor(s) and turns on the indoor blower motor.

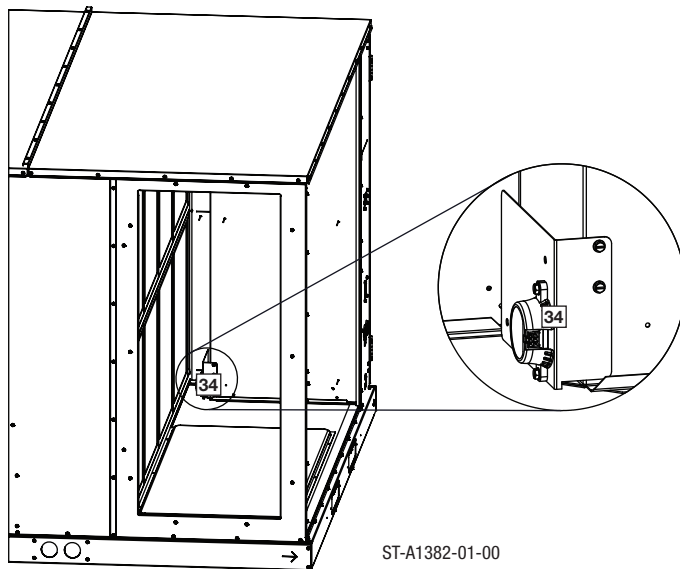

R **GE** **H** **Y** **B** **360** **A** **C** **G** **40** **B** **C** **A** ********
1 **23** **4** **5** **6** **789** **10** **11** **12** **13 14** **15** **16** **17** **18 19 20 21**

1—Brand

R = Rheem

2, 3—Unit Type

GE = Packaged Gas/Electric

4—Cabinet Type

H = Large Commercial

5—Refrigerant

Y = R-454B

6—Efficiency Level

B = Standard Efficiency

7,8,9—Capacity

360 = 30 Ton

10—Major Series

A = 1st Design

11—Voltage

C = 3 PH/208-230 V/60 Hz

D = 3 PH/460 V/60 Hz

Y = 3 PH/575 V/60 Hz

12—Drive

F = Belt Drive - VFD Low

G = Belt Drive - VFD Medium

H = Belt Drive - VFD High

13, 14—Heat Capacity

30 = 300,000 Btu/h

40 = 400,000 Btu/h

15—Heat Configuration

2 = 2-Stage

B = 2-Stage Stainless

16—Control

C = ClearControl & Phase Monitor

D = ClearControl & Comfort Alert

17—Minor Series

A = 1st design

18, 19, 20, 21—Option Code

See next page

FACTORY-INSTALLED OPTION CODES FOR RGEHYB360

18				19				20			21	
LV = Louver Protection				DC = Disconnect ¹				EC = Downflow Economizer			M8 = MERV 8 Filter	
HA = Hinged Access (Standard)				NP = Non-Powered Convenience Outlet				RS = Return Smoke Detector			M13 = MERV 13 Filter	
CC = Condenser Coil Coating				LF = Low Ambient								
OPTION CODE CHARACTER HIGHLIGHTED BELOW												
C	HA			A	None			0	None		A	Standard
D	LV	HA		B	LF			1	EC		D	M8
F	LV	HA	CC	C	NP			3	EC	RS	G	M13
				D	LF	NP						
				E	DC							
				F	LF	DC						
				H	NP	DC						
				K	LF	NP	DC					

¹Only available with D and Y voltage.

Instructions for Factory Installed Option(s) Selection

Note: Four characters following the model number will be utilized to designate a factory-installed option or combination of options. If no factory option(s) is required, "CA0A" follows the model number.

- **Step 1:** In the table above, based on the desired features, choose option code character from highlighted options on the left side under the number 18. For example, the option code character "F" has Louver Protection, Hinged Access, and Condenser Coil Coating.
- **Step 2:** In the table above, based on the desired features, choose option code character from highlighted options on the left side under the number 19. For example, the option code character "D" has Low Ambient and Non-powered convenience outlet.
- **Step 3:** In the table above, based on the desired features, choose option code character from highlighted options on the left side under the number 20. For example, the option code character "3" has Economizer and Return Smoke.
- **Step 4:** In the table above, based on the desired features, choose option code character from highlighted options on the left side under the number 21. For example, the option code character "D" has MERV 8 filters.
- The resulting option code from examples above is: "FD3D"
- **Step 5:** Add your option code selection to the end of model number

○ Example: RGEHYB360ACG302CA FD3D = RGEHYB360ACG302CAFD3D

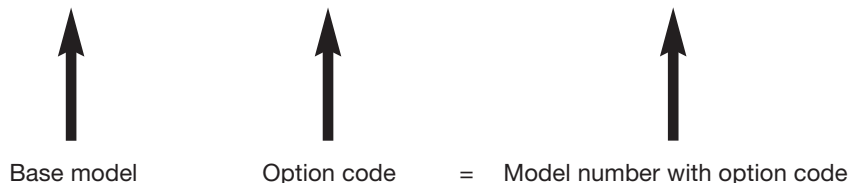

To select an RGEH Cooling and Heating unit to meet a job requirement, follow this procedure, with example, using data supplied in this specification sheet.

1. DETERMINE COOLING AND HEATING REQUIREMENTS AND SPECIFIC OPERATING CONDITIONS FROM PLANS AND SPECS.

Example:

Voltage—	460V – 3 Phase – 60 Hz
Total Cooling Capacity—	340,000 Btu/h [99.6 kW]
Sensible Cooling Capacity—	230,000 Btu/h [67.4 kW]
Heating Capacity—	136,486 Btu/h [40 kW]
*Condenser Entering Air—	95°F [35.0°C] DB
*Evaporator Mixed Air Entering—	67°F [19.4°C] WB 78°F [25.6°C] DB
*Indoor Air Flow—	11000 CFM [5191 L/s]
External Static Pressure—	1.2 in. WG [0.30 kPa]

2. SELECT UNIT TO MEET COOLING REQUIREMENTS.

Since total cooling is within range of a nominal 30 ton unit, use the cooling performance table at 95°F DB condenser inlet air. Interpolate between 9400 CFM [4436 L/s] and 13200 CFM [6230 L/s] to determine total and sensible capacity and Depression Ratio for inlet air at 11000 CFM [5191 L/s] indoor airflow (table basis):

Interpolation Formula:

$$k\text{Btu}/h_1 + \left[(\text{CFM} - \text{CFM}_1) \times \left(\frac{k\text{Btu}/h_2 - k\text{Btu}/h_1}{\text{CFM}_2 - \text{CFM}_1} \right) \right] = k\text{Btu}/h$$

Total Cooling Capacity = 350,000 Btu/h [102.6 kW]
Sensible Cooling Capacity = 259,600 Btu/h [76.1 kW]
DR = 0.105

When the entering dry bulb temperature (dbE) is not 80°F [26.7°C], the sensible capacity needs to be adjusted.
Note: total capacity is unaffected

Sensible Capacity Depression Formula:

$$\text{Cap}_{\text{sensible}} + [1.10 \times \text{CFM} \times (1 - \text{DR}) \times (\text{dbE} - 80)]$$

$$259,600 + [1.10 \times 11,000 \times (1 - 0.105) \times (78 - 80)]$$

Sensible Cooling Capacity = 237,941 Btu/h

3. CORRECT CAPACITIES OF STEP 2 FOR ACTUAL AIR FLOW.

Select correction factors from the “Airflow Correction Factors” table at the design airflow, 11000 CFM [5191 L/s]. Multiply the gross and sensible capacities determined in Step 2 with these correction factors to obtain the corrected gross capacities. Note: These may have to be interpolated to obtain.

Total Capacity Correction Factor at 11000 CFM [5191 L/s] = 1.03

Sensible Capacity Correction Factor at 11000 CFM [5191 L/s] = 1.13

Corrected Total Capacity = 350,000 x 1.03 = 360,500 Btu/h [105.7 kW]
Corrected Sensible Capacity = 237,941 x 1.13 = 268,873 Btu/h [105.7 kW]

Note: These corrected capacities are Gross Capacities, not yet corrected for blower motor heat.

4. DETERMINE BLOWER SPEED AND BHP TO MEET SYSTEM DESIGN.

Total ESP (external static pressure) per the spec of 1.2 in WG [0.30 kPa] includes the system duct and grilles. Add from the table “Component Air Resistance”, 0.19 in. WG [0.05 kPa] for wet coil and 0.35 in. WG [0.09 kPa] for downflow to get an ESP of 1.74 in. WG [0.43 kPa]. Using the “Airflow Performance Table”, at the specified 11,000 CFM and 1.74 in. WG [0.43 kPa] ESP, determine blower BHP.

RPM = 1189
BHP = 12.98
DRIVE = H

5. CALCULATE INDOOR BLOWER Btu/h HEAT EFFECT FROM MOTOR BHP IN STEP 4.

Assuming an average of 85% motor efficiency, determine the amount of heat generated by the blower motor at the specified CFM and ESP by dividing the BHP by the motor efficiency and solving for the difference. Convert this value from BTU to Btu/h, multiplying by 2542.8 Btu/h/BHP

BHP = 12.98
AVG MOTOR EFFICIENCY = 85%

INDOOR BLOWER MOTOR HEAT =

$$\left[\left(\frac{\text{BHP}}{0.85} - \text{BHP} \right) \right] \times 2542.8$$

$$= [(12.98/0.85) - 12.98] \times 2542.8 = 5825 \text{ Btu/h} [1.71 \text{ kW}]$$

6. CALCULATE THE NET COOLING CAPACITIES

Net cooling capacities can be calculated by subtracting the motor heat from the gross cooling capacities.

Net Total Capacity = Gross Total Capacity – Indoor Blower Motor Heat
= 360,500 – 5,825 = 354,675 Btu/h [103.9 kW]

Net Sensible Capacity = Gross Sensible Capacity – Indoor Blower Motor Heat
= 268,873 – 5,825 = 263,048 Btu/h [77.1 kW]

7. SELECT UNIT HEATING CAPACITY

For Gas Heating, choose the gas heat capacity that closest matches the specified heat capacity requirements.

8. CHOOSE MODEL RGEHYB360ADH

[] Designates Metric Conversions

GENERAL DATA—RGEHYB360 MODELS—30 TON

Model RGEHYB Series	360
Cooling Performance^A	
Gross Cooling Capacity Btu/h [kW]	348,000 [101.99]
EER	9.8
IEER ^B	13
Nominal CFM/AHRI Rated CFM [L/s]	11,000/9,350 [5,191/4,413]
AHRI Net Cooling Capacity Btu/h [kW]	330,000 [96.71]
Net Sensible Capacity Btu/h [kW]	231,000 [67.70]
Net Latent Capacity Btu/h [kW]	99,000 [29.01]
Net System Power kW	33.67
Compressor	
No./Type	2 / Scroll
No. Stages	5
Outdoor Sound Rating (dB)^C	
91	
Outdoor Coil—Fin Type	
Tube Type	Louvered
MicroChannel Depth in. [mm]	MicroChannel
Face Area sq. ft. [sq. m]	1 [25.4]
Rows / FPI [FPcm]	52.4 [4.87]
Indoor Coil—Fin Type	
Tube Type	Louvered
Tube Size in. [mm]	Rifled
Face Area sq. ft. [sq. m]	0.375 [9.5]
Rows / FPI [FPcm]	26.7 [2.48]
Refrigerant Control	4 / 15 [7]
Drain Connection No./Size in. [mm]	TX Valves
Outdoor Fan—Type	
No. Used/Diameter in. [mm]	Propeller
Drive Type/No. Speeds	6/24 [609.6]
CFM [L/s]	Direct / 1
No. Motors/HP	19,800 [9,344]
Motor RPM (208/230V / 460V / 575V)	6 at 3/4 HP
Indoor Fan—Type	
No. Used/Diameter in. [mm]	1,100 / 1,100 / 1,130
Drive Type	FC Centrifugal
No. Speeds	2/18x9 [457x229]
No. Motors	Belt (Adjustable)
Motor RPM (F-Drive / G-Drive / H-Drive)	Multiple
Motor Frame Size (F-Drive / G-Drive / H-Drive)	1
Filter—Type	
Furnished	Disposable
(NO.) Size Recommended in. [mm x mm x mm]	Yes
Refrigerant Charge Oz. (Sys. 1/Sys. 2) [g]	
222 [6,294]/206 [5,840]	
Weights	
Net Weight lbs. [kg]	2,541 [1,153]
Ship Weight lbs. [kg]	2,668 [1,210]

NOTE: Please look at the rating plates pasted on the side of the unit to understand the model number of your unit.

[] Designates Metric Conversions

NOTES:

A. Cooling Performance is rated at 95°F ambient, 80°F entering dry bulb, 67°F entering wet bulb. Gross capacity does not include the effect of fan motor heat. AHRI capacity is net and includes the effect of fan motor heat. Units are suitable for operation to ±20% of nominal CFM. Units are certified in accordance with the Unitary Air Conditioner Equipment certification program, which is based on AHRI Standard 340/360.

B. EER and Integrated Energy Efficiency Ratio (IEER) are rated at AHRI conditions in accordance with AHRI Standard 340/360.

C. Outdoor Sound Rating shown is tested in accordance with AHRI Standard 270

WEIGHTED SOUND POWER LEVEL (dBA)

Model	STD Rating (dBA)	Frequency (Hz)							
		63	125	250	500	1000	2000	4000	8000
RGEHYB360	82.9	62.7	70.5	73.7	78.1	78.0	74.2	68.1	59.3

COOLING PERFORMANCE DATA – RGEHYB360

wbE		ENTERING INDOOR AIR @ 80°F [26.7°C] dbE ①									
		71°F [21.7°C]			67°F [19.4°C]			63°F [17.2°C]			
		CFM [L/s]	13200 [6230]	9350 [4413]	8800 [4153]	13200 [6230]	9350 [4413]	8800 [4153]	13200 [6230]	9350 [4413]	8800 [4153]
DR ①		.05	.09	.12	.05	.09	.12	.05	.09	.12	
OUTDOOR DRY BULB TEMPERATURE °F [°C]	75 [23.9]	Total kBtu/h [kW] Sens kBtu/h [kW] Power	433.9 [127.2] 253.2 [74.2] 29.8	403.6 [118.3] 212.4 [62.3] 28.8	399.3 [117] 206.5 [60.5] 28.6	407.6 [119.5] 300.1 [88.0] 29.6	379.2 [111.1] 251.7 [73.8] 28.6	375.1 [109.9] 244.8 [71.7] 28.4	383.4 [112.4] 343.6 [100.7] 29.5	356.7 [104.5] 288.2 [84.5] 28.5	352.9 [103.4] 280.3 [82.2] 28.3
	80 [26.7]	Total kBtu/h [kW] Sens kBtu/h [kW] Power	429.5 [125.9] 250.8 [73.5] 31.2	399.5 [117.1] 210.4 [61.7] 30.1	395.3 [115.9] 204.6 [60] 30.0	403.2 [118.2] 297.7 [87.3] 31.0	375.1 [109.9] 249.7 [73.2] 29.9	371.1 [108.8] 242.8 [71.2] 29.8	379 [111.1] 341.3 [100] 30.9	352.6 [103.3] 286.2 [83.9] 29.9	348.8 [102.2] 278.4 [81.6] 29.7
	85 [29.4]	Total kBtu/h [kW] Sens kBtu/h [kW] Power	423.6 [124.2] 247.7 [72.6] 32.7	394.1 [115.5] 207.8 [60.9] 31.5	389.9 [114.3] 202.1 [59.2] 31.4	397.4 [116.5] 294.6 [86.3] 32.4	369.7 [108.4] 247.1 [72.4] 31.3	365.7 [107.2] 240.3 [70.4] 31.1	373.2 [109.4] 338.2 [99.1] 32.4	347.2 [101.8] 283.7 [83.1] 31.2	343.5 [100.7] 275.9 [80.9] 31.1
	90 [32.2]	Total kBtu/h [kW] Sens kBtu/h [kW] Power	416.4 [122.0] 243.9 [71.5] 34.1	387.4 [113.5] 204.6 [60.0] 32.9	383.3 [112.3] 199 [58.3] 32.7	390.1 [114.3] 290.8 [85.2] 33.9	363 [106.4] 244 [71.5] 32.7	359.1 [105.2] 237.3 [69.5] 32.5	366 [107.3] 334.4 [98] 33.8	340.5 [99.8] 280.5 [82.2] 32.6	336.8 [98.7] 272.8 [80] 32.4
	95 [35]	Total kBtu/h [kW] Sens kBtu/h [kW] Power	407.8 [119.5] 239.4 [70.2] 35.5	379.4 [111.2] 200.8 [58.9] 34.3	375.3 [110] 195.3 [57.2] 34.1	381.5 [111.8] 286.3 [83.9] 35.3	354.9 [104] 240.2 [70.4] 34.1	351.1 [102.9] 233.6 [68.5] 33.9	357.3 [104.7] 329.9 [96.7] 35.2	332.5 [97.5] 276.7 [81.1] 34.0	328.9 [96.4] 269.1 [78.9] 33.8
	100 [37.8]	Total kBtu/h [kW] Sens kBtu/h [kW] Power	397.8 [116.6] 234.2 [68.6] 36.9	370 [108.4] 196.5 [57.6] 35.6	366.1 [107.3] 191.1 [56] 35.4	371.5 [108.9] 281.1 [82.4] 36.7	345.6 [101.3] 235.8 [69.1] 35.4	341.9 [100.2] 229.4 [67.2] 35.2	347.3 [101.8] 324.7 [95.2] 36.6	323.1 [94.7] 272.4 [79.8] 35.3	319.7 [93.7] 264.9 [77.6] 35.2
	105 [40.6]	Total kBtu/h [kW] Sens kBtu/h [kW] Power	386.3 [113.2] 228.3 [66.9] 38.3	359.4 [105.3] 191.5 [56.1] 37.0	355.6 [104.2] 186.3 [54.6] 36.8	360 [105.5] 275.3 [80.7] 38.1	335 [98.2] 230.9 [67.7] 36.8	331.4 [97.1] 224.5 [65.8] 36.6	335.9 [98.4] 318.8 [93.4] 38.1	312.5 [91.6] 267.4 [78.4] 36.7	309.1 [90.6] 260.1 [76.2] 36.5
	110 [43.3]	Total kBtu/h [kW] Sens kBtu/h [kW] Power	373.5 [109.5] 221.7 [65.0] 39.8	347.5 [101.8] 186.0 [54.5] 38.4	343.7 [100.7] 180.9 [53] 38.2	347.2 [101.8] 268.6 [78.7] 39.6	323 [94.7] 225.3 [66] 38.2	319.6 [93.7] 219.2 [64.2] 38.0	323 [94.7] 312.2 [91.5] 39.5	300.5 [88.1] 261.9 [76.8] 38.1	297.3 [87.1] 254.7 [74.6] 37.9
	115 [46.1]	Total kBtu/h [kW] Sens kBtu/h [kW] Power	359.2 [105.3] 214.4 [62.8] 41.2	334.2 [97.9] 179.9 [52.7] 39.7	330.6 [96.9] 174.9 [51.3] 39.5	333 [97.6] 261.3 [76.6] 41.0	309.8 [90.8] 219.2 [64.2] 39.5	306.4 [89.8] 213.2 [62.5] 39.3	308.8 [90.5] 304.9 [89.4] 40.9	287.3 [84.2] 255.7 [74.9] 39.5	284.2 [83.3] 248.7 [72.9] 39.3
	120 [48.9]	Total kBtu/h [kW] Sens kBtu/h [kW] Power	343.6 [100.7] 206.4 [60.5] 42.6	319.7 [93.7] 173.1 [50.7] 41.1	316.2 [92.7] 168.4 [49.4] 40.9	317.3 [93.0] 253.3 [74.2] 42.4	295.2 [86.5] 212.5 [62.3] 40.9	292.0 [85.6] 206.7 [60.6] 40.7	293.1 [85.9] 293.1 [85.9] 42.3	272.7 [79.9] 249 [73.0] 40.8	269.8 [79.1] 242.2 [71.0] 40.6
	125 [51.7]	Total kBtu/h [kW] Sens kBtu/h [kW] Power	326.5 [95.7] 197.7 [57.9] 44.0	303.8 [89.0] 165.8 [48.6] 42.5	300.5 [88.1] 161.3 [47.3] 42.3	300.2 [88.0] 244.6 [71.7] 43.8	279.3 [81.9] 205.2 [60.1] 42.3	276.3 [81.0] 199.5 [58.5] 42.1	276.1 [80.9] 276.1 [80.9] 43.7	256.9 [75.3] 241.7 [70.8] 42.2	254.1 [74.5] 235.1 [68.9] 42.0

DR —Depression ratio
dbE —Entering air dry bulb
wbE—Entering air wet bulb

Total —Total capacity x 1000 Btu/h
Sens —Sensible capacity x 1000 Btu/h
Power —kW input

NOTES: ① When the entering air dry bulb is other than 80°F [27°C], adjust the sensible capacity from the table by adding [1.10 x CFM x (1 – DR) x (dbE – 80)].

[] Designates Metric Conversions

HEATING PERFORMANCE DATA

Heating Performance (Gas)	RGEHYB360A**30	RGEHYB360A**40
Heating Input Btu/h [kW] (1st Stage / 2nd Stage)	150,000 / 300,000 [43.95 / 87.9]	200,000 / 400,000 [58.6 / 117.2]
Heating Output Btu/h [kW] (1st Stage / 2nd Stage)	121,500 / 243,000 [35.6 / 71.2]	162,000 / 324,000 [47.47 / 94.93]
Temperature Rise Range °F [°C] (1st Stage / 2nd Stage)	15-45 [8.3-25] / 15-45 [8.3-25]	25-55 [13.9-30.6] / 25-55 [13.9-30.6]
Number of Burners	12	14
Number of Stages	2	2
Main Limit Temperature °F	135	150
Rollout Limit Temperature °F	350	350
Max Outlet Air Temperature [°C]	170	170
Steady State Efficiency (%)	81	81
Gas Connection Pipe Size in. [mm]	1.00 [25.4]	1.00 [25.4]

[] Designates Metric Conversions

AIRFLOW PERFORMANCE—30 TON – 60 HZ – DOWNFLOW

Model RGEHYB360		Voltage 208/230, 460, 575 — 3 phase 60 Hz																																													
Air Flow CFM [L/s]		External Static Pressure—Inches of Water [kPa]																																													
		0.1 [0.2]	0.2 [0.5]	0.3 [0.7]	0.4 [1.0]	0.5 [1.2]	0.6 [1.5]	0.7 [1.7]	0.8 [2.0]	0.9 [2.2]	1.0 [2.5]	1.1 [2.7]	1.2 [3.0]	1.3 [3.2]	1.4 [3.5]	1.5 [3.7]	1.6 [4.0]	1.7 [4.2]	1.8 [4.5]	1.9 [4.7]	2.0 [5.0]																										
RPM	W	RPM	W	RPM	W	RPM	W	RPM	W	RPM	W	RPM	W	RPM	W	RPM	W	RPM	W	RPM	W	RPM	W																								
8800 [4153]	—	—	—	808	4215	830	4455	851	4686	871	4909	889	5123	906	5328	922	5525	937	5713	983	6313	1006	6676	1029	7044	1052	7416	1073	7793	1109	8066	1123	8252	1138	8464	1153	8701	1169	8964								
9000 [4247]	—	—	—	821	4465	834	4715	855	4956	875	5188	894	5412	911	5628	928	5835	943	6033	988	6680	1012	7056	1034	7436	1056	7820	1077	8209	1112	8419	1126	8636	1142	8878	1158	9146	1174	9440	1191	9759						
9200 [4341]	—	—	—	812	4465	803	4466	826	4725	847	4975	868	5217	887	5451	905	5675	922	5891	939	6099	979	6680	1003	7059	1026	7443	1048	7831	1069	8224	1106	8496	1120	8716	1136	8961	1152	9231	1169	9527	1186	9849	1204	10196		
9600 [4530]	817	4733	539	4993	860	5244	880	5486	899	5720	917	5946	933	6162	970	6677	994	7060	1017	7448	1040	7840	1061	8237	1100	8863	1124	9113	1140	9389	1146	9312	1163	9611	1180	9935	1211	10285	1216	10660							
9800 [4624]	830	5007	852	5268	873	5519	893	5763	911	5997	928	6223	961	6672	985	7060	1009	7451	1031	7848	1053	8248	1074	8653	1109	8863	1124	9113	1140	9389	1146	9312	1163	9611	1180	9935	1211	10285	1216	10660							
10000 [4719]	844	5289	866	5550	886	5802	905	6046	923	6282	939	6508	977	7057	1000	7453	1023	7853	1045	8257	1066	8666	1103	8830	1118	9183	1134	9462	1151	9766	1168	10095	1186	10450	1205	10830	1224	11236	1244	11668							
10200 [4813]	858	5578	879	5840	899	6093	917	6337	934	6573	968	7053	991	7462	1014	7856	1087	8285	1058	8677	1079	9094	1112	9249	1128	9530	1145	9837	1162	10169	1180	10526	1199	10909	1218	11318	1238	11752	1258	12211							
10400 [4908]	872	5874	892	6137	911	6391	929	6636	959	7047	983	7450	1005	1065	1102	1059	1120	10569	1138	10945	1156	11347	1176	11774	1195	12226	1216	12704	1237	13207	1259	13736	—	—	—	—	—	—	—	—	—						
10600 [5002]	885	6178	905	6441	924	6696	941	6942	974	7446	998	7858	1020	8274	1042	8694	1063	9119	1100	9368	1116	9655	1133	9967	1150	10304	1168	10687	1187	11055	1206	11489	1226	11908	1246	12373	—	—	—	—	—						
10800 [5096]	899	6489	918	6753	936	7008	965	7440	989	7856	1012	8276	1034	8700	1055	9129	1076	9562	1110	9711	1127	10025	1144	10365	1162	10731	1181	11184	1194	11603	1214	12048	1234	12518	1255	13013	—	—	—	—	—						
11200 [5285]	925	7134	948	7422	972	7846	996	8274	1018	8706	1032	9147	1053	9592	1074	10041	1109	10177	1126	10524	1144	10898	1163	11297	1182	11721	1202	12171	1222	12646	1243	13147	1265	13673	—	—	—	—	—	—	—						
11400 [5379]	938	7467	964	7838	987	8270	1010	8706	1032	9147	1053	9592	1074	10041	1109	10177	1126	10524	1144	10898	1163	11297	1182	11721	1202	12171	1222	12646	1243	13147	1265	13673	—	—	—	—	—	—	—	—	—						
11600 [5474]	955	7829	979	8264	1002	8705	1024	9149	1046	9598	1066	10051	1102	10219	1120	10569	1138	10945	1156	11347	1176	11774	1195	12226	1216	12704	1237	13207	1259	13736	—	—	—	—	—	—	—	—	—	—	—						
11800 [5568]	971	8257	994	8701	1016	9150	1038	9602	1059	10059	1079	10521	1114	10610	1132	10988	1150	11393	1169	11822	1189	12277	1210	12758	1231	13264	1253	13795	—	—	—	—	—	—	—	—	—	—	—	—	—	—					
12000 [5663]	986	8696	1008	9148	1030	9605	1051	10066	1072	10331	1107	10646	1125	11028	1144	11434	1163	11866	1183	12324	1203	12807	1225	13316	1246	13850	—	—	—	—	—	—	—	—	—	—	—	—	—	—	—	—	—				
12200 [5757]	1001	9145	1023	9605	1044	10070	1065	10540	1101	10679	1119	11063	1138	11472	1157	11907	1177	12367	1197	12853	1218	13364	1240	13901	1262	14463	—	—	—	—	—	—	—	—	—	—	—	—	—	—	—	—	—	—			
12400 [5851]	1015	9604	1037	10073	1057	10546	1077	11024	1113	11093	1131	11505	1150	11943	1170	12406	1191	12894	1212	13408	1234	13948	1256	14512	—	—	—	—	—	—	—	—	—	—	—	—	—	—	—	—	—	—	—	—			
12600 [5946]	1029	10074	1050	10551	1070	11032	1106	11120	1125	11535	1144	11975	1164	12440	1184	12931	1206	13448	1227	13990	1250	14558	—	—	—	—	—	—	—	—	—	—	—	—	—	—	—	—	—	—	—	—	—	—			
12800 [6040]	1043	10554	1063	11039	1100	11143	1118	11560	1138	12003	1158	12471	1178	12865	1199	13484	1221	14028	1243	14599	—	—	—	—	—	—	—	—	—	—	—	—	—	—	—	—	—	—	—	—	—	—	—	—			
13000 [6134]	1056	11044	1076	11538	1112	11581	1131	12026	1151	12497	1172	12994	1193	13515	1215	14063	1237	14635	1260	15234	—	—	—	—	—	—	—	—	—	—	—	—	—	—	—	—	—	—	—	—	—	—	—	—	—		
13200 [6229]	1069	11545	1105	11598	1125	12046	1145	12519	1165	13018	1186	13543	1208	14093	1230	14668	1253	15269	—	—	—	—	—	—	—	—	—	—	—	—	—	—	—	—	—	—	—	—	—	—	—	—	—	—	—	—	—

NOTE: F-Drive left of first bold line, G-Drive in between bold lines, H-Drive right of second bold line.

Drive Package	F										G										H																										
Motor H.P. [W]	7.5 [5,592.7]										10 [7,457.0]										15 [11,185.5]																										
Blower Sheave	BK130H										BK120H										BK190H																										
Motor Sheave	1VP71										1VP75										1VP71																										
Turns Open	1	2	3	4	5	6	1	2	3	4	5	6	1	2	3	4	5	6	1	2	3	4	5	6	1	2	3	4	5	6	1	2	3	4	5	6	1	2	3	4	5	6					
RPM	938	912	886	859	833	807	1,069	1,041	1,013	972	951	931	1,254	1,219	1,184	1,147	1,111	1,074	1,047	1,019	984	948	912	876	840	804	768	732	696	660	624	588	552	516	480	444	408	372	336	300	264	228	192	156	120	84	48

- NOTES:** 1. Factory sheave settings are shown in bold type.
 2. Do not set motor sheave below minimum or maximum turns open shown.
 3. Re-adjustment of sheave required to achieve rated airflow at AHRI minimum External Static Pressure.
 4. Drive data shown is for vertical airflow with dry coil. Add component resistance (below) to duct resistance to determine total External Static Pressure.
 5. A RPM meter is required.

[] Designates Metric Conversions

COMPONENT AIRFLOW RESISTANCE — 30 TON — 60 HZ — DOWNFLOW

Airflow	AIRFLOW CORRECTION FACTORS			COMPONENT AIRFLOW RESISTANCE					
	Total kBtu/h	Sensible kBtu/h	Power kW	Wet Coil	Downflow Economizer RA Damper Open	Horizontal Economizer RA Damper Open	Concentric Diffuser RXRN-AD88 & Transition RXMC-C109	MERV 8 Filter	MERV 13 Filter
CFM [L/s]	Resistance — Inches of Water [kPa]								
8800 [4153]	0.99	0.95	1.00	0.10 [.02]	0.26 [.06]	0.11 [.03]	0.30 [.07]	0.15 [.04]	0.13 [.03]
9200 [4341]	0.99	0.98	1.00	0.12 [.03]	0.28 [.07]	0.12 [.03]	0.36 [.09]	0.16 [.04]	0.15 [.04]
9600 [4341]	1.00	1.01	1.00	0.13 [.03]	0.30 [.07]	0.13 [.03]	0.43 [.11]	0.16 [.04]	0.16 [.04]
10000 [4719]	1.01	1.04	1.01	0.15 [.04]	0.32 [.07]	0.14 [.03]	0.50 [.12]	0.17 [.04]	0.17 [.04]
10400 [4908]	1.02	1.08	1.01	0.16 [.04]	0.34 [.08]	0.15 [.04]	0.56 [.14]	0.18 [.04]	0.18 [.05]
10800 [5096]	1.03	1.11	1.01	0.18 [.04]	0.37 [.09]	0.16 [.04]	0.63 [.16]	0.19 [.05]	0.19 [.05]
11200 [5285]	1.03	1.14	1.02	0.19 [.05]	0.39 [.10]	0.17 [.04]	0.69 [.17]	0.20 [.05]	0.21 [.05]
11600 [5474]	1.04	1.17	1.02	0.21 [.05]	0.41 [.10]	0.18 [.04]	0.76 [.19]	0.20 [.05]	0.22 [.05]
12000 [5663]	1.05	1.20	1.02	0.22 [.05]	0.44 [.11]	0.19 [.05]	0.82 [.20]	0.21 [.05]	0.23 [.06]
12400 [5851]	1.06	1.23	1.03	0.24 [.06]	0.46 [.11]	0.20 [.05]	0.89 [.22]	0.22 [.05]	0.24 [.06]
12800 [6040]	1.06	1.26	1.03	0.25 [.06]	0.49 [.12]	0.21 [.05]	0.96 [.24]	0.23 [.06]	0.26 [.06]
13200 [6229]	1.07	1.29	1.04	0.27 [.07]	0.52 [.13]	0.22 [.05]	1.02 [.25]	0.24 [.06]	0.27 [.07]

[] Designates Metric Conversions

COMPONENT AIRFLOW RESISTANCE — 30 TON — 60 HZ — SIDEFLOW

Airflow	AIRFLOW CORRECTION FACTORS				COMPONENT AIRFLOW RESISTANCE					
	CFM [L/s]	Total kBtu/h	Sensible kBtu/h	Power kW	Wet Coil	Downflow Economizer RA Damper Open	Horizontal Economizer RA Damper Open	Concentric Diffuser RXRN-AD88 & Transition RXMC-CL09	MERV 8 Filter	MERV 13 Filter
		0.99	0.97	0.99						
8800 [4153]	0.99	0.97	0.99	0.99	0.10 [0.02]	0.26 [0.06]	0.11 [0.03]	0.30 [0.07]	0.15 [0.04]	0.13 [0.03]
9200 [4341]	1.00	0.99	1.00	1.00	0.12 [0.03]	0.28 [0.07]	0.12 [0.03]	0.36 [0.09]	0.16 [0.04]	0.15 [0.04]
9600 [4341]	1.00	1.01	1.00	1.00	0.13 [0.03]	0.30 [0.07]	0.13 [0.03]	0.43 [0.11]	0.16 [0.04]	0.16 [0.04]
10000 [4719]	1.01	1.03	1.01	1.01	0.15 [0.04]	0.32 [0.07]	0.14 [0.03]	0.50 [0.12]	0.17 [0.04]	0.17 [0.04]
10400 [4908]	1.02	1.05	1.01	1.01	0.16 [0.04]	0.34 [0.08]	0.15 [0.04]	0.56 [0.14]	0.18 [0.04]	0.18 [0.05]
10800 [5096]	1.03	1.07	1.01	1.01	0.18 [0.04]	0.37 [0.09]	0.16 [0.04]	0.63 [0.16]	0.19 [0.05]	0.19 [0.05]
11200 [5285]	1.03	1.09	1.02	1.02	0.19 [0.05]	0.39 [0.10]	0.17 [0.04]	0.69 [0.17]	0.20 [0.05]	0.21 [0.05]
11600 [5474]	1.04	1.11	1.02	1.02	0.21 [0.05]	0.41 [0.10]	0.18 [0.04]	0.76 [0.19]	0.20 [0.05]	0.22 [0.05]
12000 [5663]	1.05	1.13	1.02	1.02	0.22 [0.05]	0.44 [0.11]	0.19 [0.05]	0.82 [0.20]	0.21 [0.05]	0.23 [0.06]
12400 [5851]	1.06	1.15	1.03	1.03	0.24 [0.06]	0.46 [0.11]	0.20 [0.05]	0.89 [0.22]	0.22 [0.05]	0.24 [0.06]
12800 [6040]	1.07	1.17	1.03	1.03	0.25 [0.06]	0.49 [0.12]	0.21 [0.05]	0.96 [0.24]	0.23 [0.06]	0.26 [0.06]
13200 [6229]	1.07	1.19	1.04	1.04	0.27 [0.07]	0.52 [0.13]	0.22 [0.05]	1.02 [0.25]	0.24 [0.06]	0.27 [0.07]

[] Designates Metric Conversions

ELECTRICAL DATA – RGEHYB SERIES

		360ACF	360ACG	360ACH	360ADF	360ADG	360ADH	360AYF	360AYG	360AYH
Unit Information	Unit Operating Voltage Range	187-253	187-253	187-253	414-506	414-506	414-506	518-633	518-634	518-635
	Volts	208/230	208/230	208/230	460	460	460	575	575	575
	Phase	3	3	3	3	3	3	3	3	3
	Hz	60	60	60	60	60	60	60	60	60
	Minimum Circuit Ampacity	147/147	153/153	166/166	69	72	78	52	54	58
	Minimum Circuit Ampacity with Power Exhaust	157/157	163/163	176/176	74	77	82	55	57	61
	Minimum Overcurrent Protection Device Size	175/175	175/175	200/200	80	80	90	60	60	70
	Minimum Overcurrent Protection Device Size with Power Exhaust	175/175	200/200	200/200	80	90	90	60	70	70
	Maximum Overcurrent Protection Device Size	200/200	200/200	200/200	90	90	100	70	70	70
Maximum Overcurrent Protection Device Size with Power Exhaust	200/200	200/200	225/225	90	100	100	70	70	70	
Compressor Motor	No.	2	2	2	2	2	2	2	2	2
	Volts	208/230	208/230	208/230	460	460	460	575	575	575
	Phase	3	3	3	3	3	3	3	3	3
	Amps (RLA), Comp. 1	54.7	54.7	54.7	24.0	24.0	24.0	19.2	19.2	19.2
	Amps (LRA), Comp. 1	386.3	386.3	386.3	182.0	182.0	182.0	131.0	131.0	131.0
	Amps (RLA), Comp. 2	31.8	31.8	31.8	15.6	15.6	15.6	12.4	12.4	12.4
	Amps (LRA), Comp. 2	255.0	255.0	255.0	140.0	140.0	140.0	107.6	107.6	107.6
Condenser Motor	No.	6	6	6	6	6	6	6	6	6
	Volts	208/230	208/230	208/230	460	460	460	575	575	575
	Phase	1	1	1	1	1	1	1	1	1
	HP	3/4	3/4	3/4	3/4	3/4	3/4	3/4	3/4	3/4
	Amps (FLA, each)	4.2	4.2	4.2	2.3	2.3	2.3	1.2	1.2	1.2
	Amps (LRA, each)	11.5	11.5	11.5	5.9	5.9	5.9	4.2	4.2	4.2
Evaporator Fan	No.	1	1	1	1	1	1	1	1	1
	Volts	208/230	208/230	208/230	460	460	460	575	575	575
	Phase	3	3	3	3	3	3	3	3	3
	HP	7.5	10	15	7.5	10	15	7.5	10	15
	Amps (FLA, each)	21.0	27.0	40.5	9.6	12.5	18.0	7.7	10.0	13.8
	Amps (LRA, each)	127.0	152.0	210.0	63.5	76.0	105.0	50.8	60.8	93.6

MANUAL MOTOR STARTER AMP SETPOINT

	Motor Part No.	51-102826-10	51-102826-11	51-107478-01	51-107478-02
	Motor HP	10	10	15	15
Motor Nameplate Amps	208V	27.0	—	39.5	—
	230V	25.0	—	36.0	—
	460V	12.5	—	18.0	—
	575V	—	10.0	—	14.4
Motor SF amps	208V	31.1	—	45.4	—
	230V	28.8	—	41.4	—
	460V	14.4	—	20.7	—
	575V	—	11.5	—	16.6
Manual Motor Starter Amp Range	208/230V	25.0-32.0	—	40.0-54.0	—
	460V	10.0-16.0	—	20.0-25.0	—
	575V	—	8.0-12.0	—	16.0-20.0
Motor Starter Part No.	208/230V	42-107877-05	—	42-107877-06	—
	460V	42-107877-02	—	42-107877-04	—
	575V	—	42-107877-01	—	42-107877-03
Manual Motor Starter Amp Setpoint	208V	32.0*	—	47.0*	—
	230V	30.0	—	43.0	—
	460V	15.0	—	22.0	—
	575V	—	12.0	—	17.0
Unit Model No.	208/230V	RGEHYB360ACG	—	RGEHYB360ACH	—
	460V	RGEHYB360ADG	—	RGEHYB360ADH	—
	575V	—	RGEHYB360AYG	—	RGEHYB360AYH

*NOTE: Units ship from factory set for 230 volt operation. Setpoint must be adjusted for 208 volt operation.

A2L INSTALLATION REFRIGERATION SAFETY DATA

Model		RGEHYB360
Refrigerant Charge Weight (oz) Circuit 1/Circuit 2		222/206
Minimum circulation airflow, Qmin (CFM)		375
Installed Altitude (ft. above sea level)	Altitude Adjustment Factor	Minimum Total Conditioned Room Area, T _{Amin} (sq. ft.)
0	1.000	208
1000	1.025	213
2000	1.051	219
3000	1.078	224
4000	1.107	230
5000	1.138	237
6000	1.170	243
6500	1.187	247

UNIT DIMENSIONS

TOP VIEW

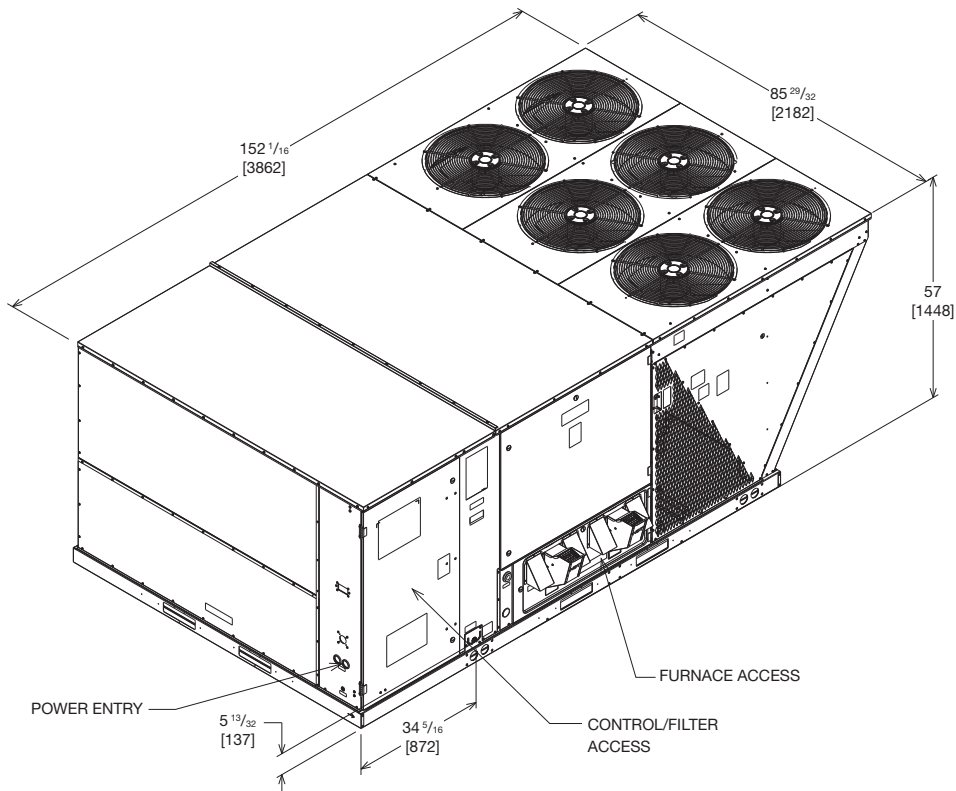

NOTE: ALL MEASURES ARE ON A FORMAT OF INCHES [MM].

ST-A1125-01A-00

BOTTOM VIEW

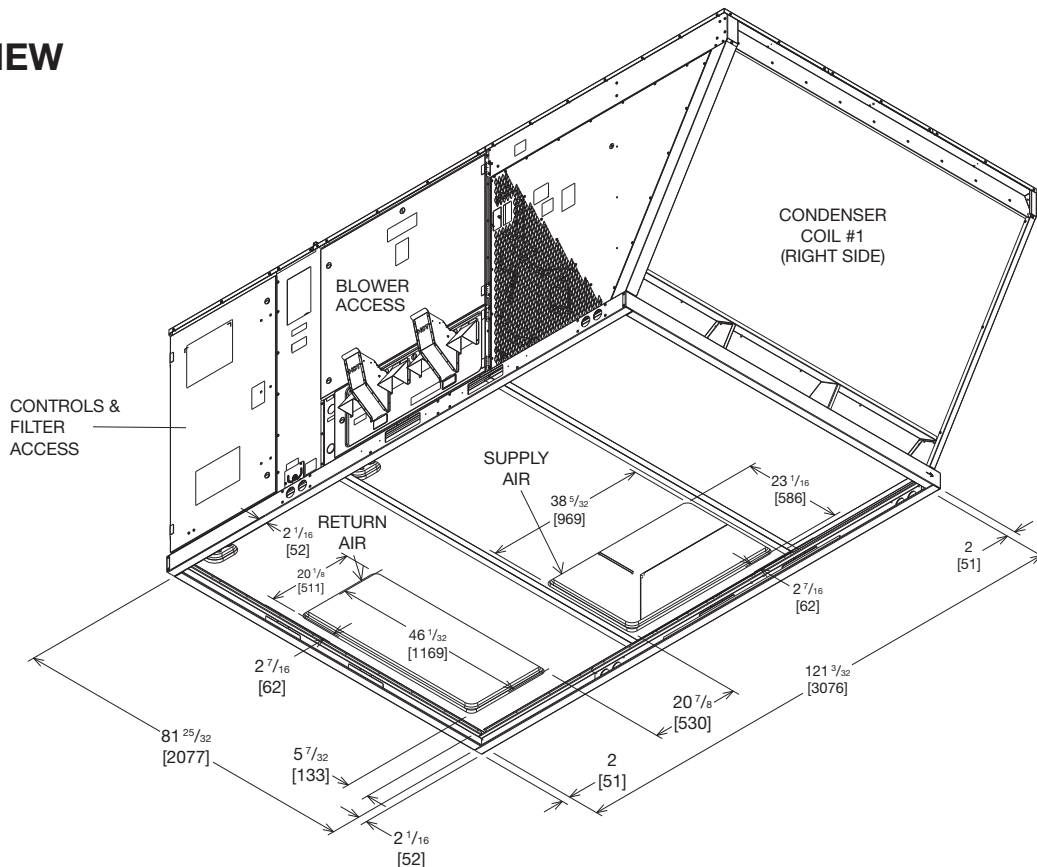

NOTE: ALL MEASURES ARE ON A FORMAT OF INCHES [MM].

ST-A1125-02A-00

[] Designates Metric Conversions

SUPPLY AND RETURN DIMENSIONS FOR HORIZONTAL APPLICATIONS (VIEW FROM REAR DUCT SIDE)

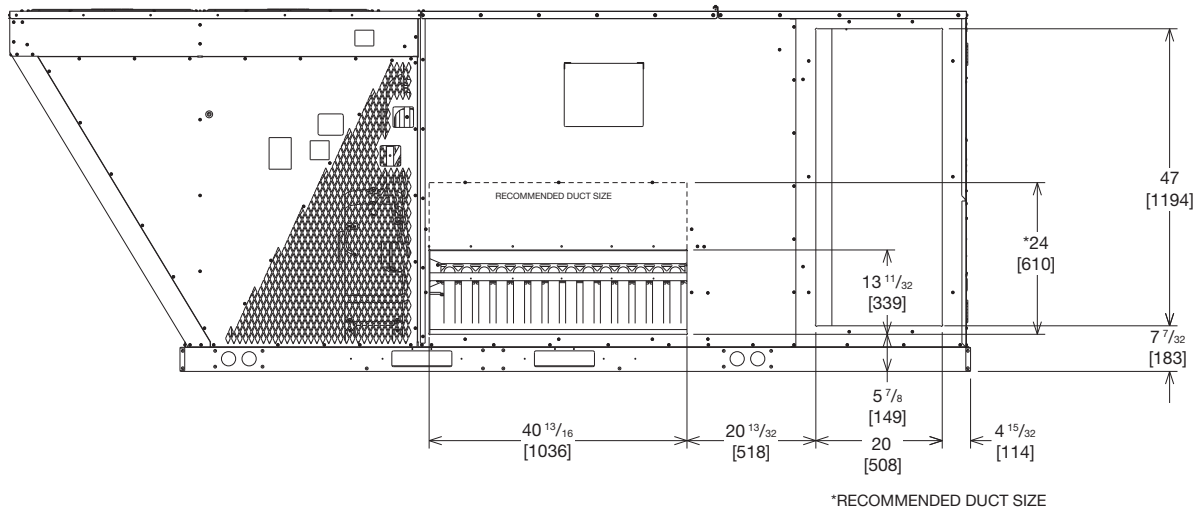

NOTE: ALL MEASURES ARE ON A FORMAT OF INCHES [MM].

ST-A1125-08A-00

DUCT SIDE VIEW (REAR)

SUPPLY AND RETURN DIMENSIONS FOR DOWNFLOW APPLICATIONS (VIEW FROM BOTTOM UP)

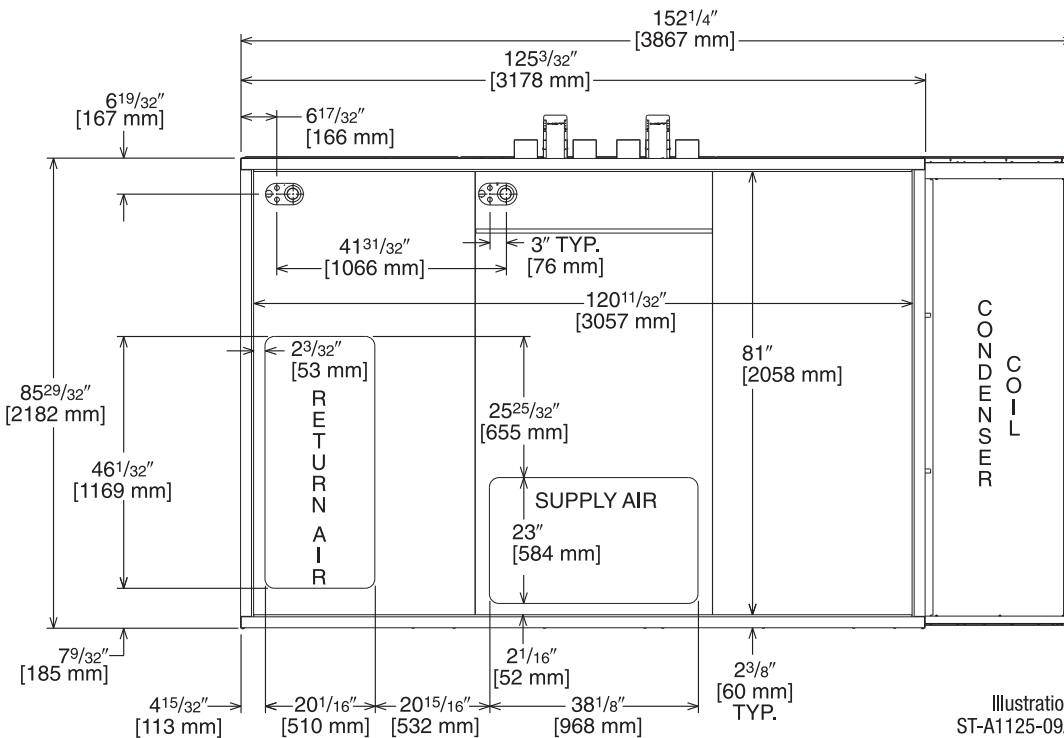
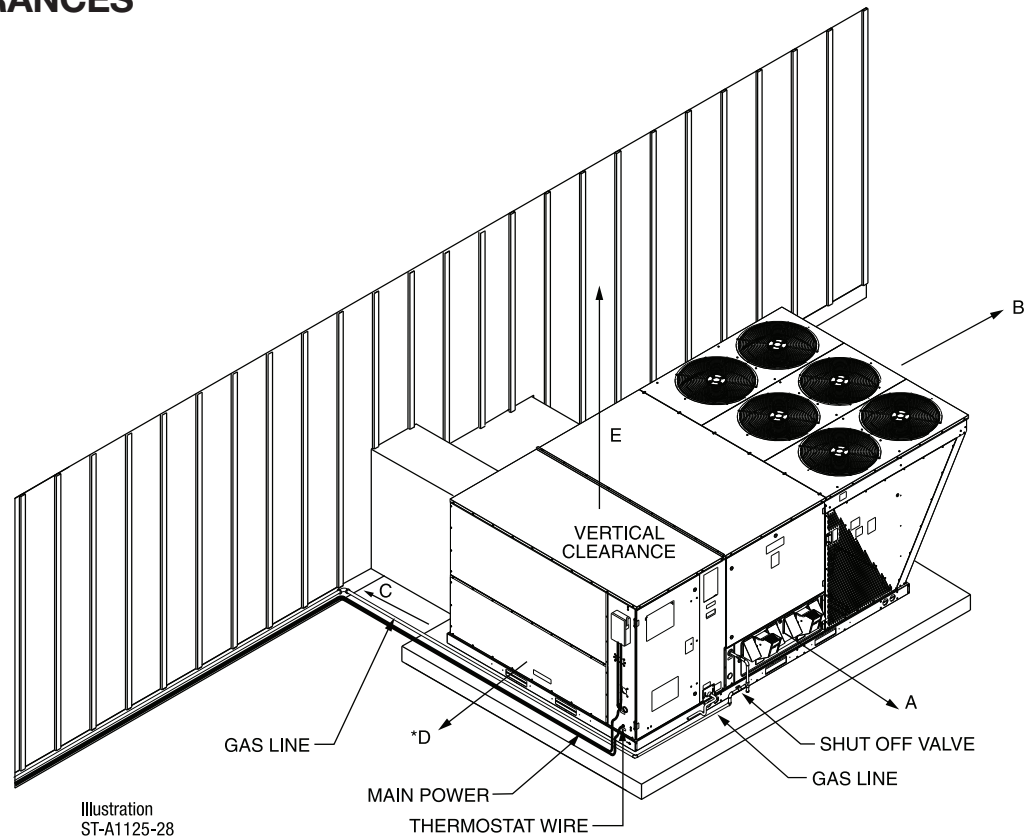

Illustration
ST-A1125-09A

BOTTOM VIEW

[] Designates Metric Conversions

REQUIRED UNIT CLEARANCES



CLEARANCES

The following minimum clearances are recommended for proper unit performance and serviceability.

Recommended Clearance In. [mm]	Location
80" [2032]	A - Front
18" [457]	B - Condenser Coil
18" [457] / 42" [1067]	+C - Duct Side
18" [457] / 48" [1219]	*D - Evaporator End
60" [1524]	E - Above
+ Without Horizontal Economizer 18" [457 mm]. With Horizontal Economizer 42" [1067 mm]. * Without Economizer 18" [457 mm]. With Economizer 48" [1219 mm].	

[] Designates Metric Conversions

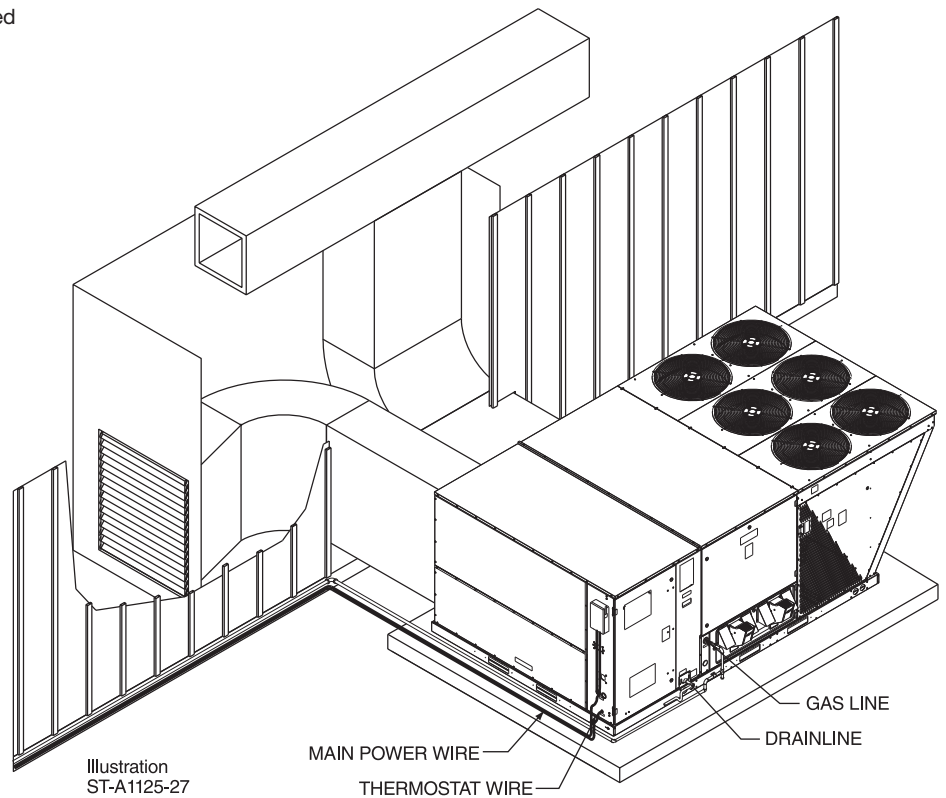

WEIGHTS

CORNER WEIGHTS BY PERCENTAGE			
A	B	C	D
32%	27%	16%	24%

CORNER WEIGHTS MEASURED AT BASE OF UNIT

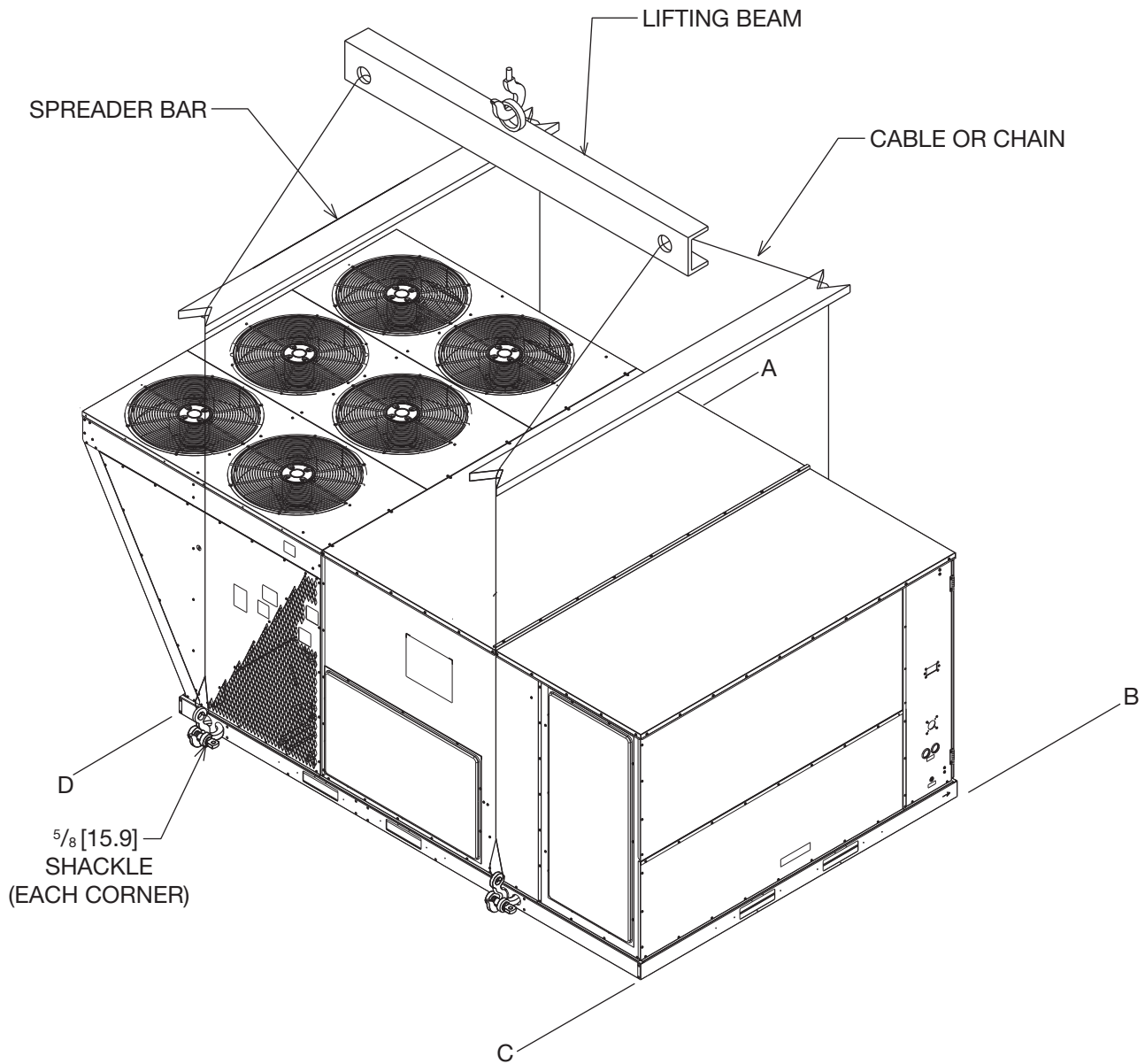

NOTE: ALL MEASURES ARE ON A FORMAT OF INCHES [MM].

ST-A1125-25-00

[] Designates Metric Conversions

FIELD-INSTALLED ACCESSORY EQUIPMENT

Accessory	Model Number	Shipping Weight Lbs. [kg]	Installed Weight Lbs. [kg]	Factory Installation Available?
Economizers				
DDC Economizer with Single Enthalpy (Downflow) <i>RRS Economizer with Honeywell Controller</i>	AXRD-01RMDCM3	277 [125.6]	168 [76.2]	Yes
DDC Economizer with Single Enthalpy (Downflow) <i>RRS Economizer with Honeywell Controller with Smoke Detector</i>	AXRD-01RMDDM3	277 [125.6]	168 [76.2]	Yes
DDC Economizer with Single Enthalpy (Horizontal) <i>RRS Economizer with Honeywell Controller</i>	AXRD-01RMHCM3	333 [151.0]	301 [36.5]	No
Non-DDC Economizer with Single Enthalpy (Downflow) <i>RRS Economizer with Siemens Controller</i>	RXRD-51RHDAM3	277 [125.6]	168 [76.2]	Yes
Non-DDC Economizer with Single Enthalpy (Horizontal) <i>RRS Economizer with Siemens Controller</i>	RXRD-51RHHAM3	333 [151.0]	301 [36.5]	No
Economizer Universal DDC Interface Kit	RXR-01DDC02	40 [18.1]	34 [15.4]	Yes

Accessory	Model Number	Shipping Weight Lbs. [kg]	Installed Weight Lbs. [kg]	Factory Installation Available?
Comfort Alert (1 per Compressor)	RXR-01AZ01	3 [1.4]	2 [0.9]	Yes
Communication Card, BACnet	RXR-01AY01	1 [0.5]	1 [0.5]	No
Communication Card, LonWorks	RXR-01AY02	1 [0.5]	1 [0.5]	No
Concentric Adapter/Transition	RXMC-CL09	81 [36.7]	74 [33.6]	No
Concentric Step Down Diffuser	RXRN-AD88	410 [186.0]	370 [67.8]	No
Convenience Outlet, Non-Powered	RXR-01AN01	2 [0.9]	1.5 [0.7]	Yes
Dual Enthalpy, Temperature and Humidity Sensor (for Honeywell DDC)	RXR-01AV02	1 [0.5]	1 [0.5]	No
Dual Enthalpy, Temperature and Humidity Sensor (for Siemens Controller)	PD555460	1 [0.5]	1 [0.5]	No
Fresh Air Damper ¹ , Manual	AXRF-KFA1	61 [27.7]	52 [23.6]	No
Outdoor Coil Louver Kit	AXRX-AAD01L	55 [24.8]	45 [20.3]	Yes
Low-Ambient Control Kit (1 Per Compressor)	RXRZ-C02	3 [1.4]	2 [0.9]	Yes
MERV 8 Filter	RXMF-M08A22520	2 [0.9]	1 [0.45]	Yes
MERV 13 Filter	RXMF-M13A22520	2 [0.9]	1 [0.45]	Yes
Power Exhaust (208/230V) Kit, Convertible <i>RRS</i>	RXR-01BGF05C	119 [54.0]	59 [26.8]	No
Power Exhaust (460V) Kit, Convertible <i>RRS</i>	RXR-01BGF05D	119 [54.0]	59 [26.8]	No
Roofcurb, 14"	RXKG-CBH14	184 [83.5]	176 [79.8]	No
Roofcurb Adapter to RXKG-CAF14	RXR-01CJCF14	555 [251.7]	505 [229.1]	No
Roofcurb Adapter to RXRK-E56	RXR-01CJCE56	465 [210.9]	415 [188.2]	No
Sensor, Carbon Dioxide (Wall Mount)	RXR-01AR02	3 [1.4]	2 [1.0]	No
Sensor, Room Humidity	RHC-ZNS4	1 [0.5]	1 [0.5]	No
Sensor, Room Temperature and Relative Humidity	RHC-ZNS5	1 [0.5]	1 [0.5]	No
Unfused Service Disconnect	RXR-01AP01	10 [4.5]	9 [4.1]	Yes

¹Motorized Kit and Manual Fresh Air Damper must be combined for a complete Motorized Outside Air Damper Selection.

[] Designates Metric Conversions

COMMUNICATION CARDS

Field-Installed



BACnet COMMUNICATION CARD RXXR-AY01

The field-installed BACnet Communication Card allows the RTU-C unit controller to communicate with a third party building management system that supports the BACnet Application Specific Controller device profile. The BACnet Communication Module plugs onto the unit RTU-C controller and allows communication between the RTU-C and the BACnet MSTP network.



LonWorks COMMUNICATION CARD RXXR-AY02

The field-installed LonWorks Communication Card allows the RTU-C unit controller to communicate with a third party building management system that supports the LonMark Space Comfort Controller (SCC) functional profile or LonMark Discharge Air Controller (DAC) functional profile. The LonMark Communication Module plugs onto the RTU-C controller and allows communication between the RTU-C and a LonWorks Network.

CONCENTRIC DIFFUSER APPLICATION

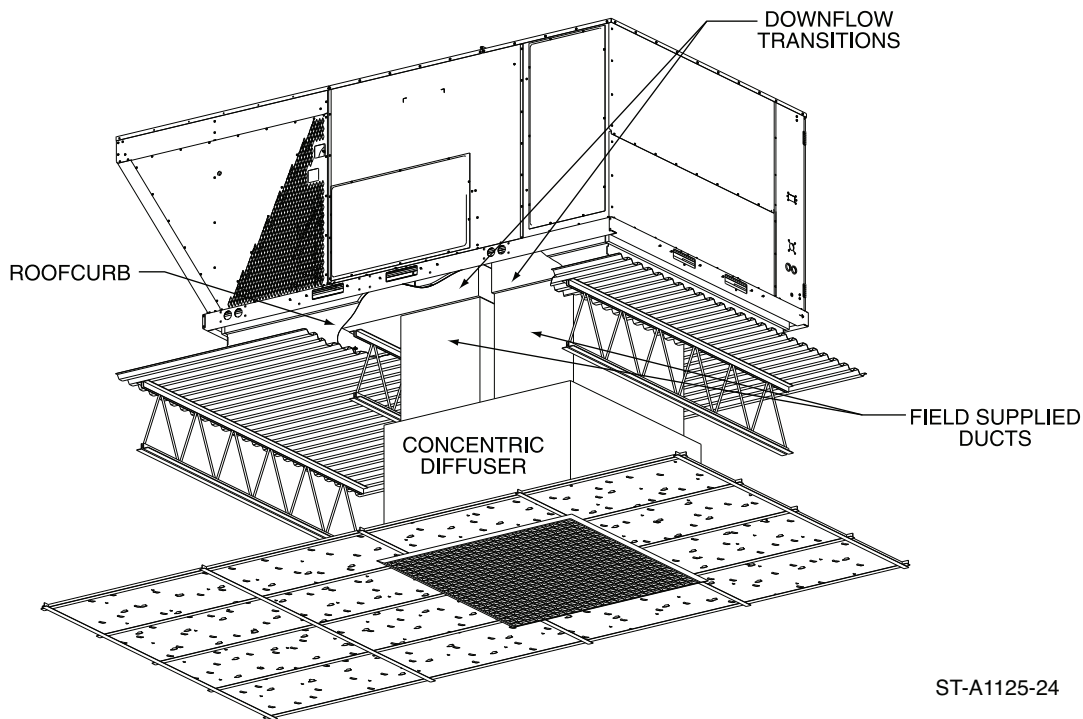

ST-A1125-24

RXMC-CL09—Concentric Adapter/Transition

- Used with RXRN-AD88 Concentric Diffusers

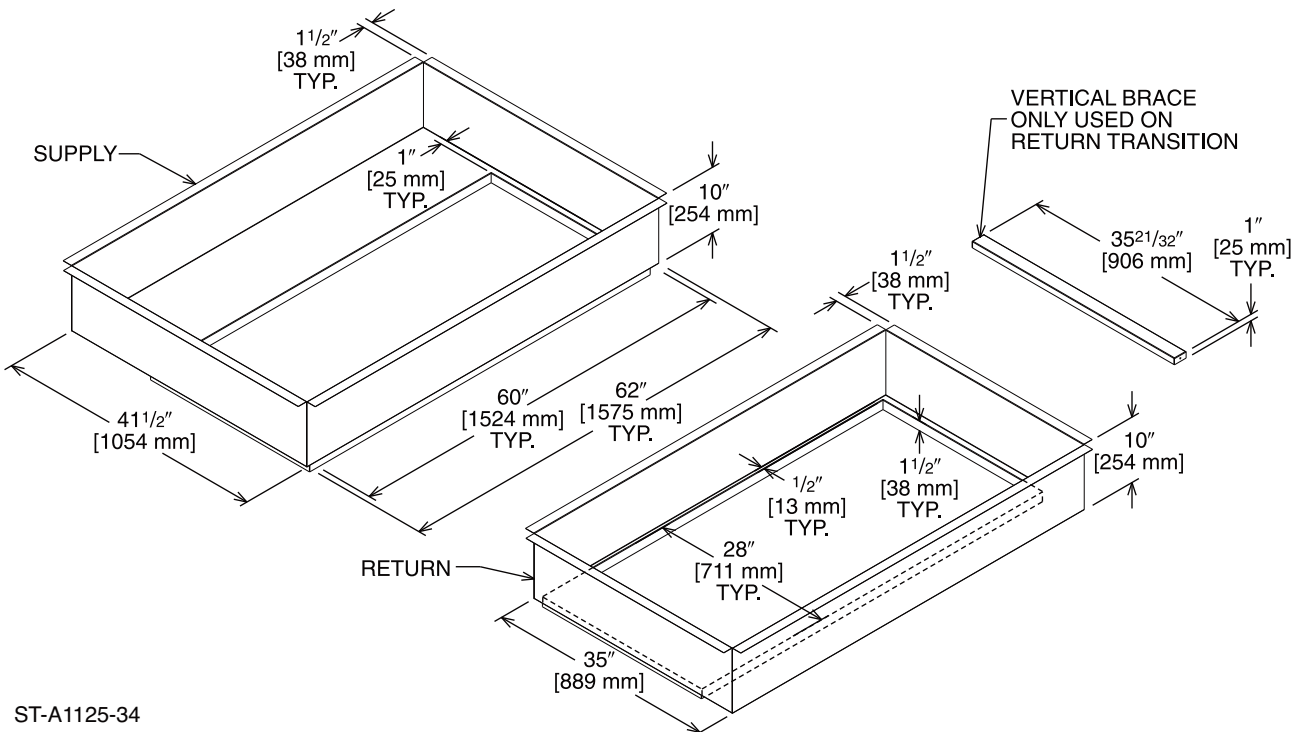

ST-A1125-34

[] Designates Metric Conversions

CONCENTRIC STEP DOWN DIFFUSER

RXRN-AD88

- All aluminum diffuser with aluminum return air eggcrate
- Built-in anti-sweat gasket
- Molded fiberglass supports
- Built-in hanging supports
- Diffuser box constructed of sheet metal insulated with 1" [25.4 mm] 1.5 lbs. [.7 kg] duct liner
- Double deflection diffuser with the blades secured by spring steel

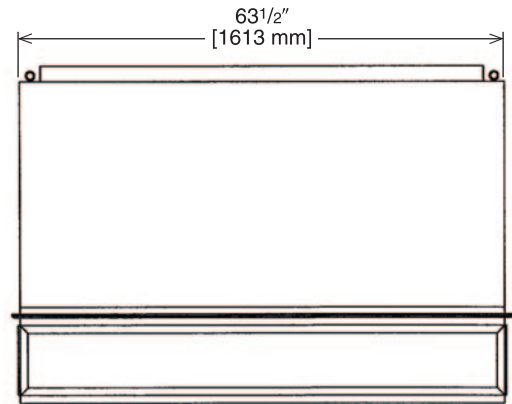
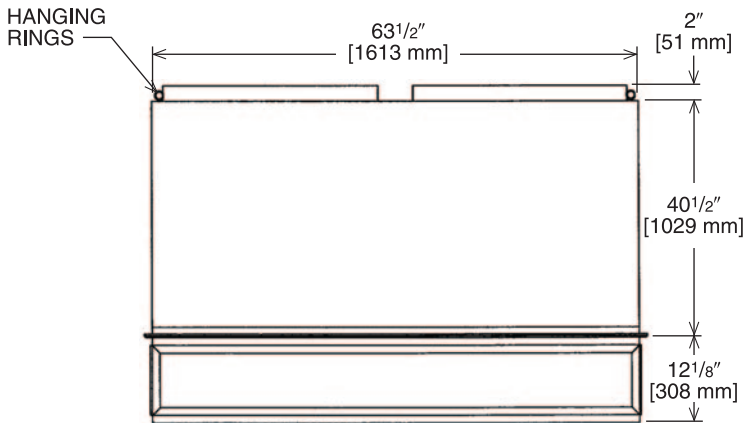
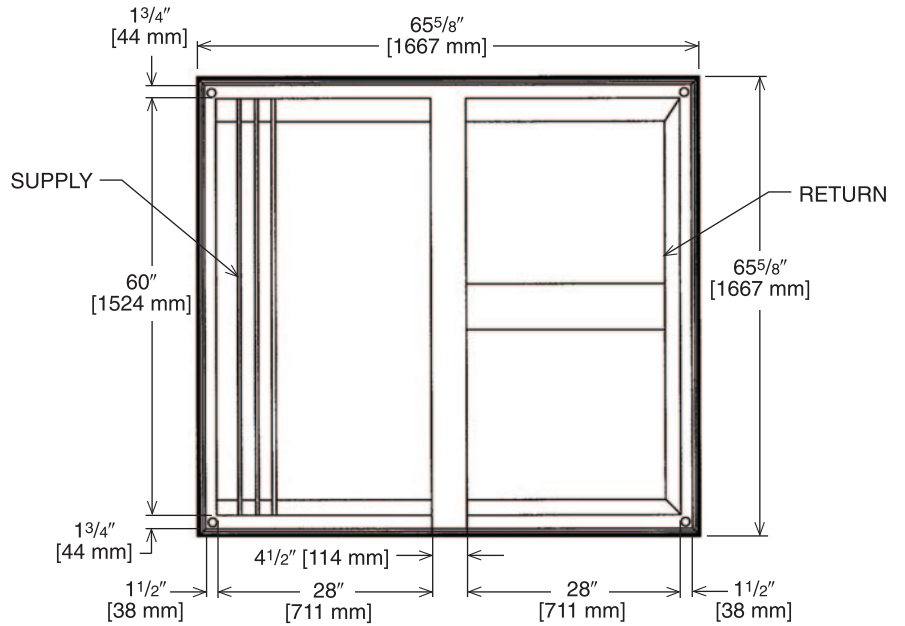

CONCENTRIC DIFFUSER SPECIFICATIONS

PART NUMBER	CFM [L/s]	STATIC PRESSURE	THROW FEET	NECK VELOCITY	JET VELOCITY
RXRN-AD88	10000 [4719]	0.51	46-54	907	907
	10500 [4955]	0.58	50-58	953	953
	11000 [5191]	0.65	53-61	998	998
	11500 [5427]	0.73	55-64	1043	1043
	12000 [5663]	0.82	58-67	1089	1089
	12500 [5898]	0.91	61-71	1134	1134
	13000 [6134]	1.00	64-74	1179	1179

[] Designates Metric Conversions

DDC ECONOMIZER WITH SINGLE ENTHALPY (DOWNFLOW) RRS ECONOMIZER WITH HONEYWELL JADE CONTROLLER

Factory or Field-Installed

AXRD-01RMDCM3

RXXR-AV02—Dual Enthalpy, Temperature and Humidity Sensor (for Honeywell DDC)

RXXR-AR02—Sensor, Carbon Dioxide (Wall Mount)

- Features **Honeywell** controls
- Gear-driven direct drive actuator
- Fully modulating (0-100%)
- Low leakage dampers
- Slip-in design for easy installation
- Plug-in polarized 12-pin and 4-pin electrical connections
- Pre-configured—no field adjustments necessary
- Standard barometric relief damper
- Single enthalpy with dual enthalpy upgrade kit available
- CO₂ input sensor available
- Field assembled hood ships with economizer
- Economizer ships complete for downflow duct application
- Optional remote minimum position potentiometer (270 ohm) (Honeywell #S963b1136) is available from Prostock
- Field-installed power exhaust available

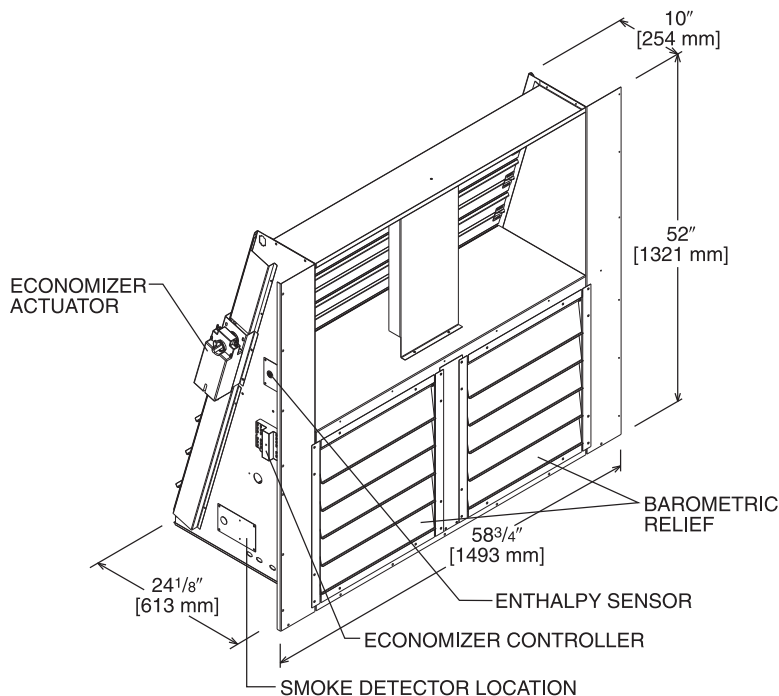

TOLERANCE ± .125

ST-A1125-19

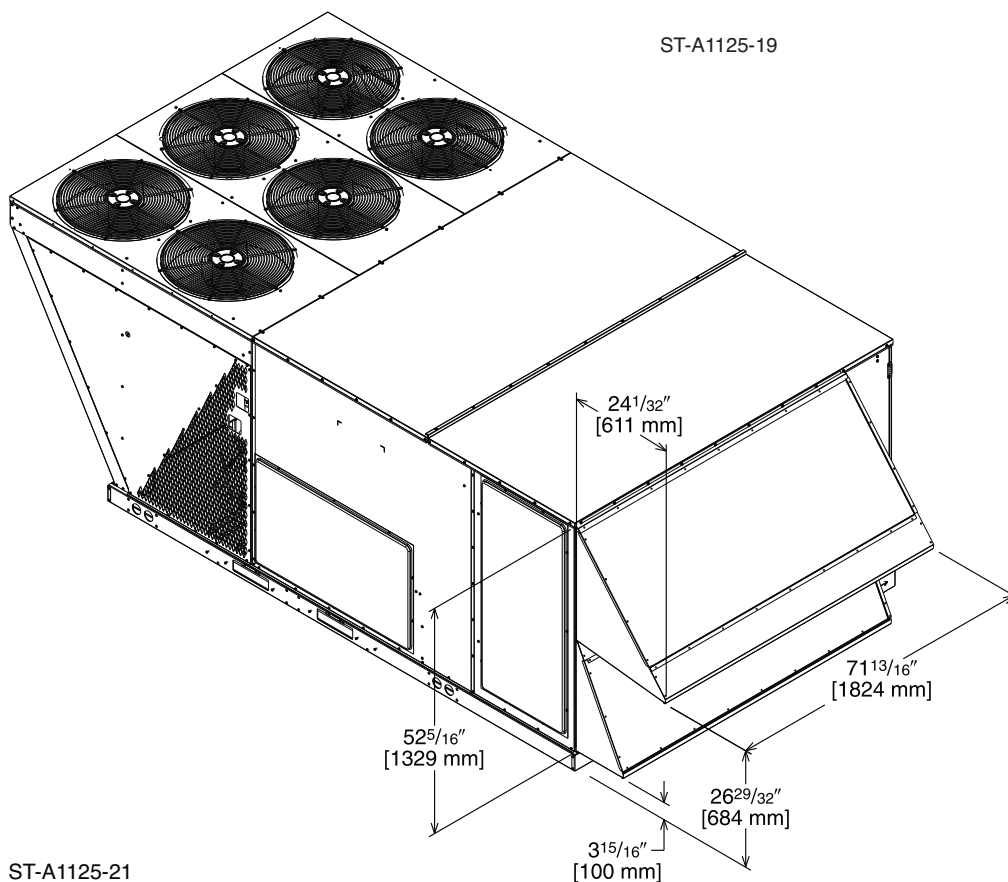

ST-A1125-21

[] Designates Metric Conversions

DDC ECONOMIZER WITH SINGLE ENTHALPY (DOWNFLOW) RRS ECONOMIZER WITH HONEYWELL CONTROLLER & SMOKE DETECTOR

Factory or Field-Installed

AXRD-01RMDDM3

RXR-02—Dual Enthalpy, Temperature and Humidity Sensor (for Honeywell DDC)

RXR-02—Sensor, Carbon Dioxide (Wall Mount)

- Features **Honeywell** controls
- Gear-driven direct drive actuator
- Fully modulating (0-100%)
- Low leakage dampers
- Slip-in design for easy installation
- Plug-in polarized 12-pin and 4-pin electrical connections
- Pre-configured—no field adjustments necessary
- Standard barometric relief damper
- Single enthalpy with dual enthalpy upgrade kit available
- CO₂ input sensor available
- Field-assembled hood ships with economizer
- Economizer ships complete for horizontal duct application
- Optional remote minimum position potentiometer (270 ohm) (Honeywell #S963b1136) is available from Prostock
- Field-installed power exhaust available
- If connected to a building automation system (BAS), all economizer functions can be viewed on the (BAS) or 16 characters x 2 rows of text LCD screen
- If connected to thermostat, all economizer functions can be viewed on 16 characters x 2 rows of text LCD screen

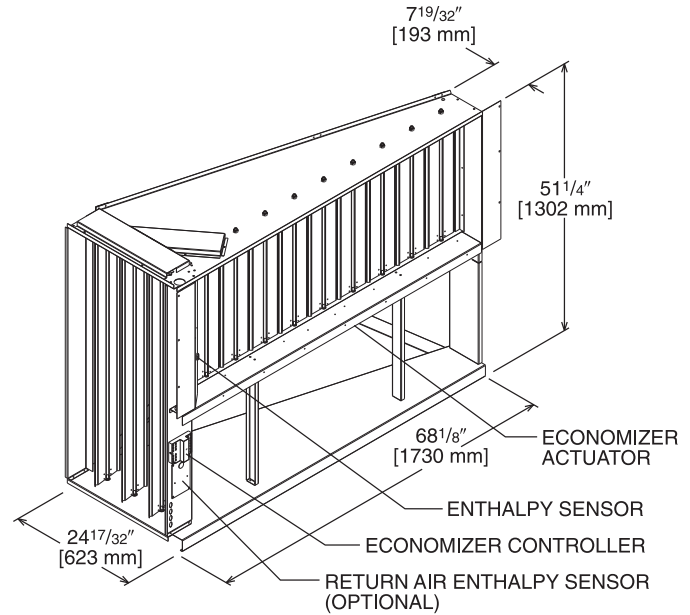

TOLERANCE ± .125

ST-A1125-20

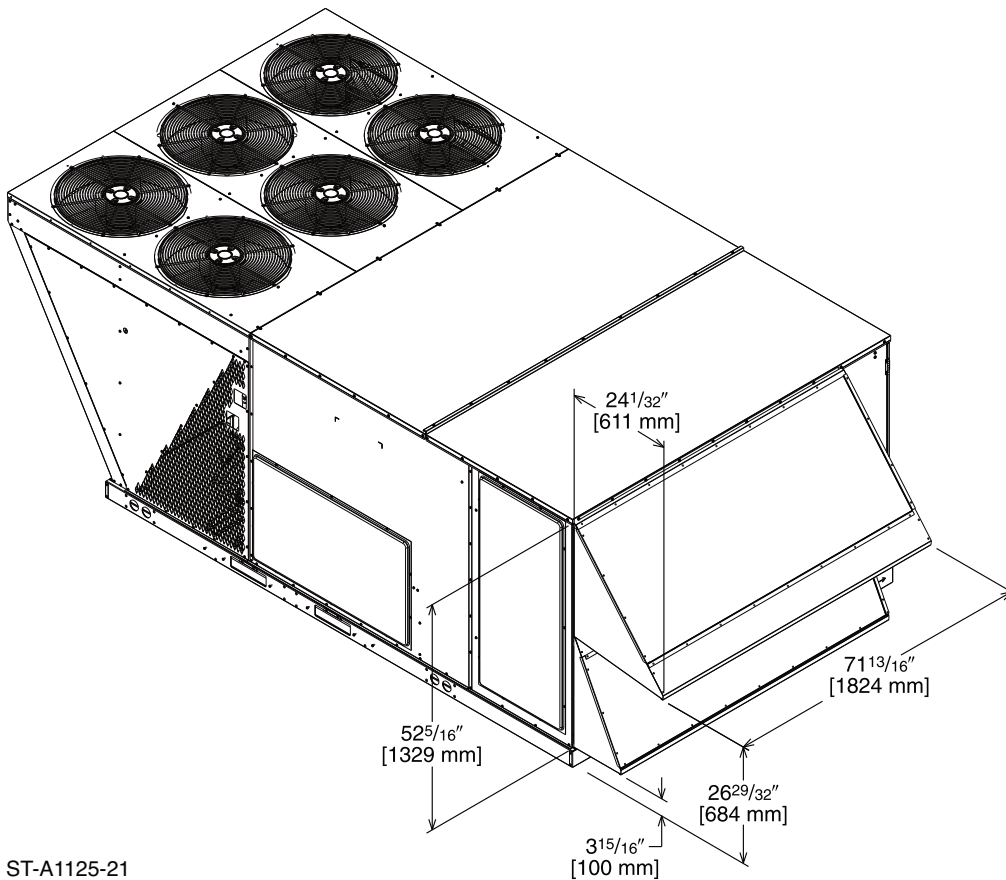

ST-A1125-21

[] Designates Metric Conversions

DDC ECONOMIZER (HORIZONTAL) RRS ECONOMIZER WITH HONEYWELL CONTROLLER

Field-Installed Only

AXRD-01RMHCM3

RXX-02—Dual Enthalpy, Temperature and Humidity Sensor (for Honeywell DDC)

RXX-02—Sensor, Carbon Dioxide (Wall Mount)

- Features **Honeywell** controls
- Gear-driven direct drive actuator
- Fully modulating (0-100%)
- Low leakage dampers
- Slip-in design for easy installation
- Plug-in polarized 12-pin and 4-pin electrical connections
- Pre-configured—no field adjustments necessary
- Standard barometric relief damper
- Single enthalpy with dual enthalpy upgrade kit available
- CO₂ input sensor available
- Field-assembled hood ships with economizer
- Economizer ships complete for horizontal duct application
- Optional remote minimum position potentiometer (270 ohm) (Honeywell #S963b1136) is available from Prostock
- Field-installed power exhaust available

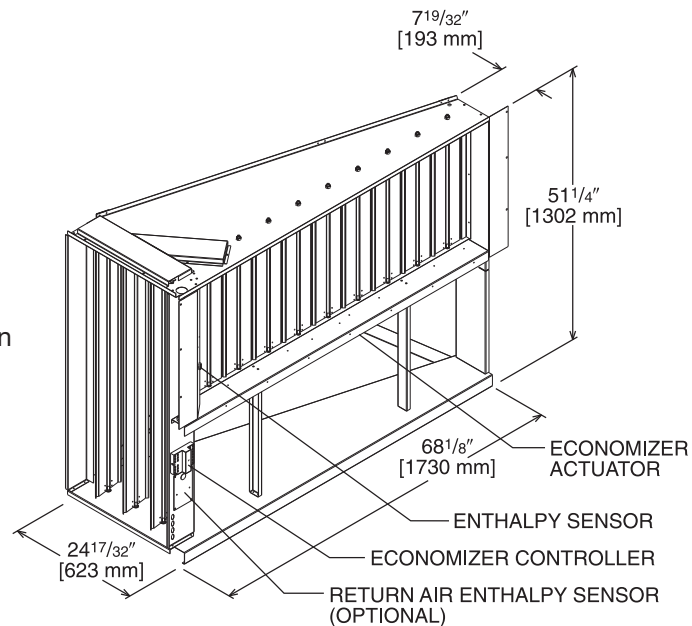

TOLERANCE ± .125

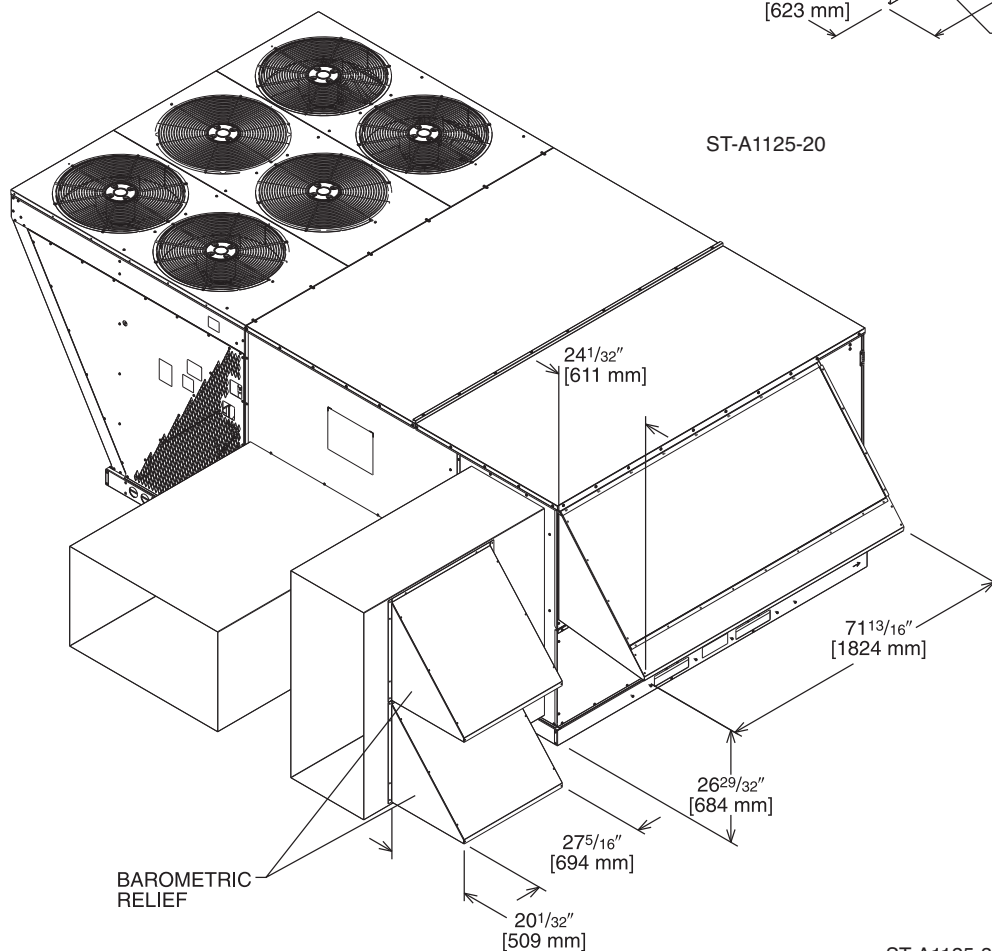

[] Designates Metric Conversions

NON-DDC ECONOMIZER WITH SINGLE ENTHALPY (DOWNFLOW) RRS ECONOMIZER WITH SIEMENS CONTROLLER

Factory or Field-Installed

RXRD-51RHDAM3

PD555460—Dual Enthalpy, Temperature and Humidity Sensor (for Siemens Non-DDC)

RXX-AR02—Sensor, Carbon Dioxide (Wall Mount)

- Features **Siemens** controls
- Gear-driven direct drive actuator
- Fully modulating (0-100%)
- Low leakage dampers
- Slip-in design for easy installation
- Plug-in polarized 12-pin and 4-pin electrical connections
- Pre-configured—no field adjustments necessary
- Standard barometric relief damper
- Single enthalpy with dual enthalpy upgrade kit available
- CO₂ input sensor available
- Economizer ships complete for downflow duct application
- Field-assembled hood ships with economizer
- Ultra low leak dampers meet California Title 24 requirements and ASHRAE 90.1
- Field-installed power exhaust available
- Can be converted to DDC operation with the economizer universal DDC interface kit (RXX-DDC02)

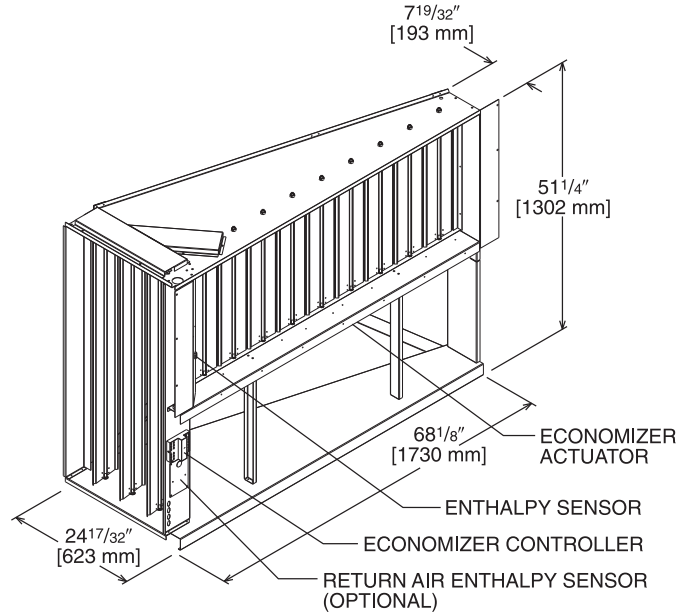

TOLERANCE ± .125

ST-A1125-20

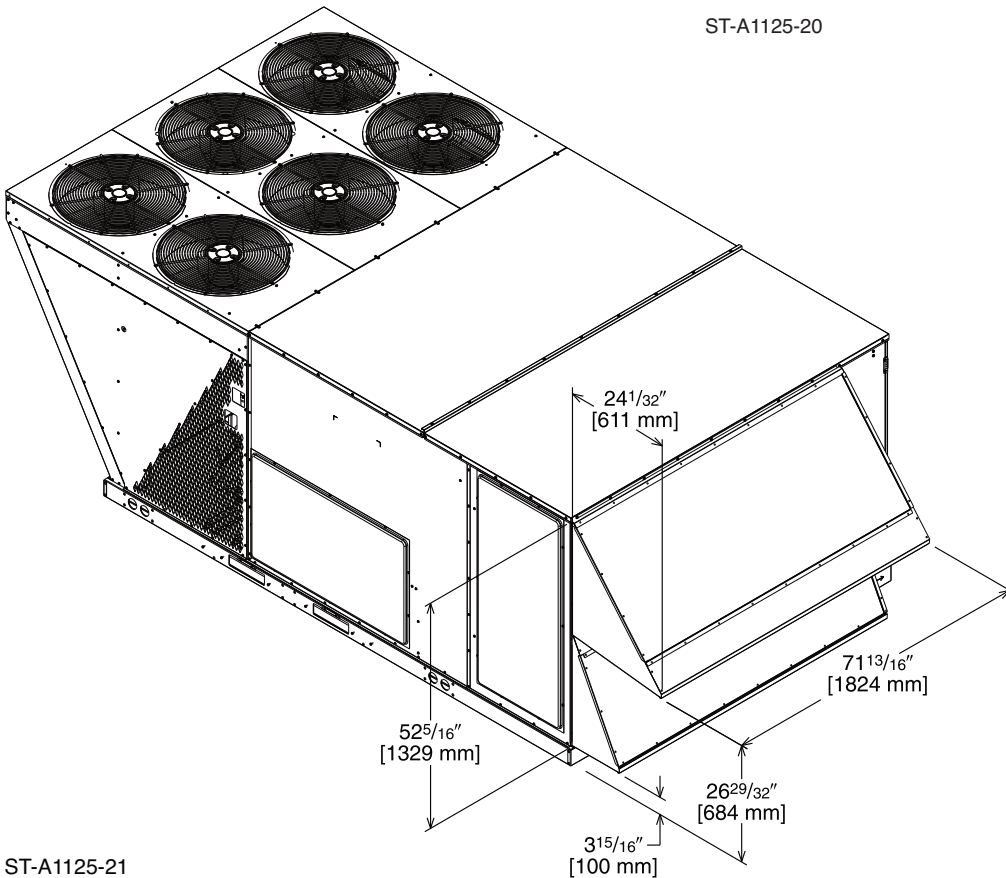

ST-A1125-21

[] Designates Metric Conversions

NON-DDC ECONOMIZER WITH SINGLE ENTHALPY (HORIZONTAL) RRS ECONOMIZER WITH SIEMENS CONTROLLER

Field-Installed Only

RXRD-51RHHAM3

PD555460—Dual Enthalpy, Temperature and Humidity Sensor (for Siemens Non-DDC)

RXXR-AR02—Sensor, Carbon Dioxide (Wall Mount)

- Features **Siemens** controls
- Gear-driven direct drive actuator
- Fully modulating (0-100%)
- Low leakage dampers
- Slip-in design for easy installation
- Plug-in polarized 12-pin and 4-pin electrical connections
- Pre-configured—no field adjustments necessary
- Standard barometric relief damper
- Single enthalpy with dual enthalpy upgrade kit available
- CO₂ input sensor available
- Field-assembled hood ships with economizer
- Economizer ships complete for horizontal duct application
- Ultra low leak dampers meet California Title 24 requirements and ASHRAE 90.1
- Field-installed power exhaust available
- Can be converted to DDC operation with the economizer universal DDC interface kit (RXXR-DDC02)

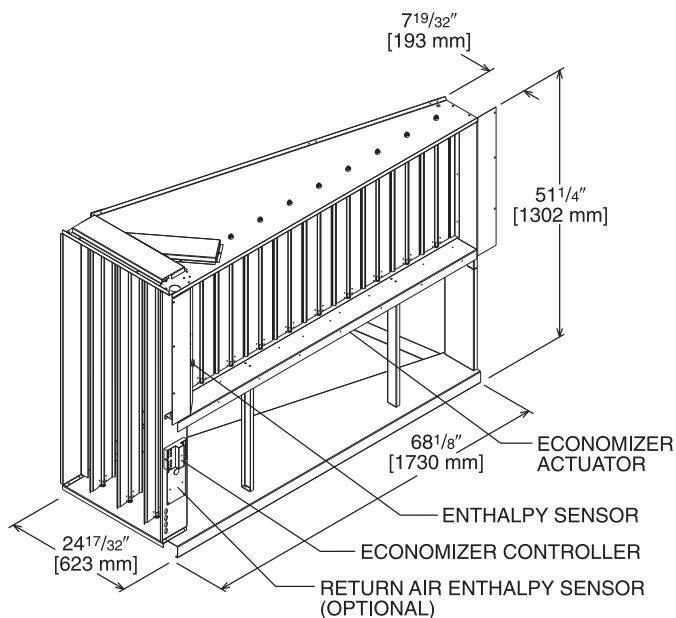

TOLERANCE ± .125

ST-A1125-20

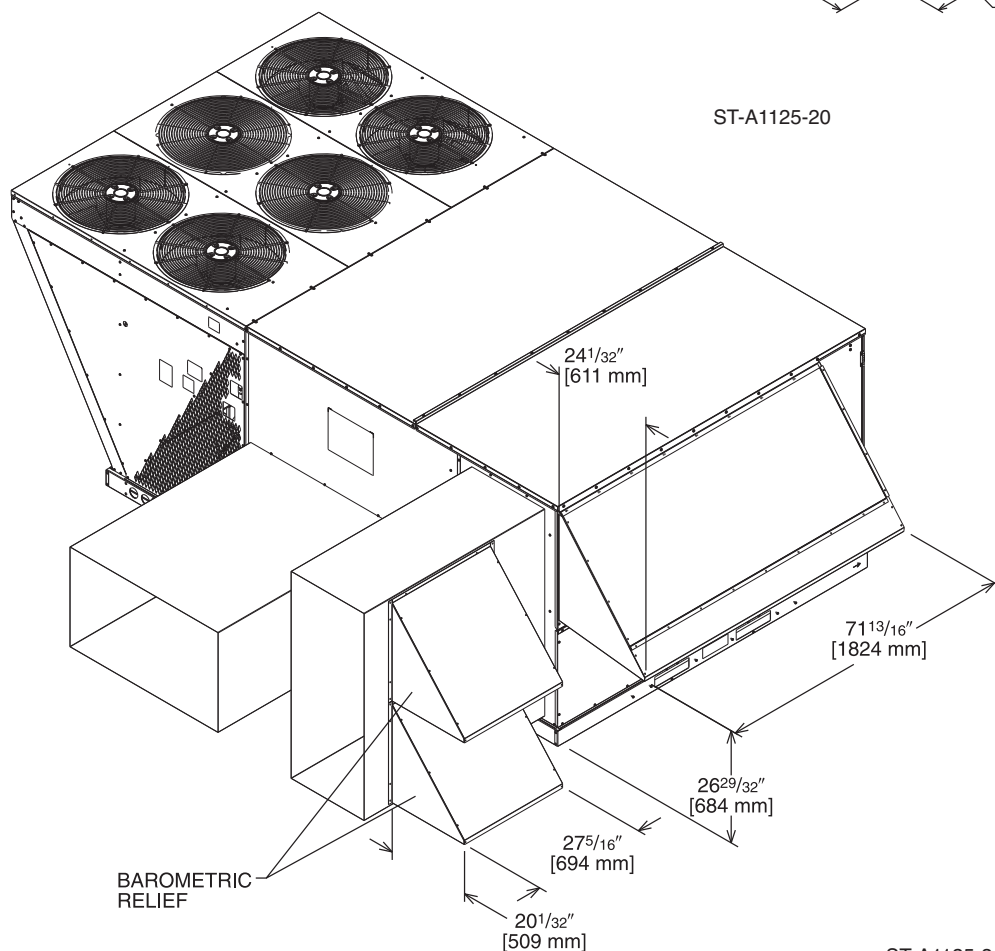

ST-A1125-31

[] Designates Metric Conversions

ECONOMIZER UNIVERSAL DDC INTERFACE KIT

Factory or Field-Installed

RXXR-DDC02

- Allows any non-DDC Economizer to be used with a ClearControl DDC model
- Mounts on the Economizer
- Provides mounting location for Economizer Controller
- Provides wire management for excess wire

NOTE: Older DDC Models, prior to A2L, may require a field update to the ClearControl Software. The minimum version required is 3.15. Models with R-454B refrigerant will come with software version 4.0 or higher.

FRESH AIR DAMPER

AXRF-KFA1 – Fresh Air Damper, Manual

- Features **Honeywell** controls
- Gear-driven direct drive actuator
- Fully modulating (0-100%)
- Low leakage dampers
- Slip-in design for easy installation
- Plug-in polarized 12-pin and 4-pin electrical connections
- Pre-configured—no field adjustments necessary
- Addition of Dual Enthalpy upgrade kit allows limited economizer function
- CO₂ sensor input available for Demand Control Ventilation (DCV)
- Optional remote minimum position potentiometer (270 ohm) (Honeywell #S963B1136) is available from Prostock
- All fresh air damper functions can be viewed at the RTU-C unit controller display
- If connected to a Building Automation System (BAS), all fresh air damper functions can be viewed on the (BAS), 16 characters x 2 rows of text LCD screen
- If connected to thermostat, all fresh air damper functions can be viewed on 16 characters x 2 rows of text LCD screen

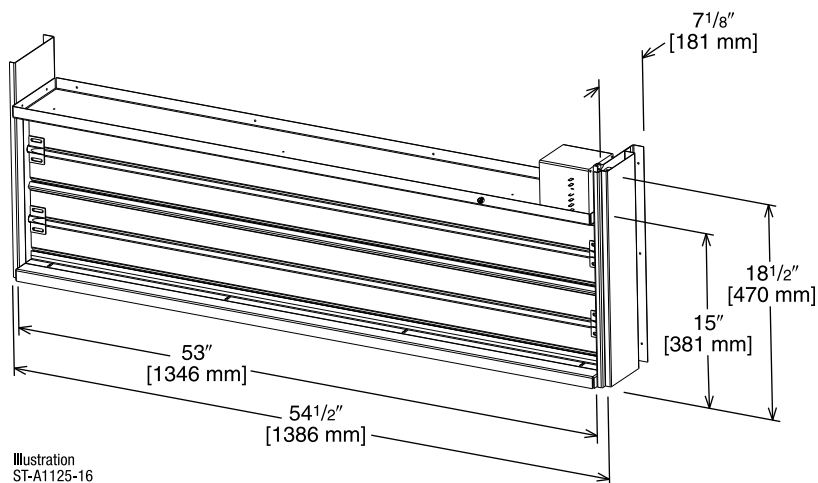

Illustration
ST-A1125-16

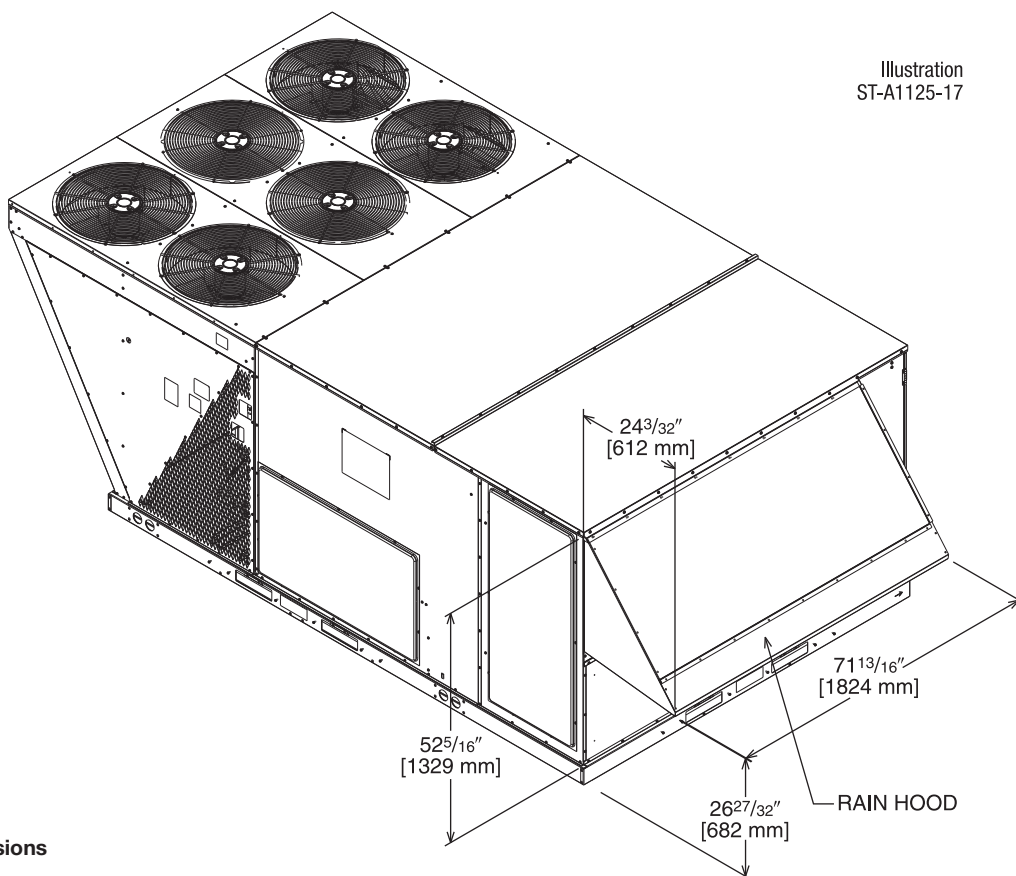

Illustration
ST-A1125-17

[] Designates Metric Conversions

POWER EXHAUST KIT, CONVERTIBLE RRS

RXRX-BGF05

*Voltage Code (C, D, or Y)

- Convertible between vertical airflow and horizontal airflow
- Compatible with all H-cabinet economizers
- Economizer sold separately

VERTICAL AIRFLOW INSTALLATION SHOWN HERE

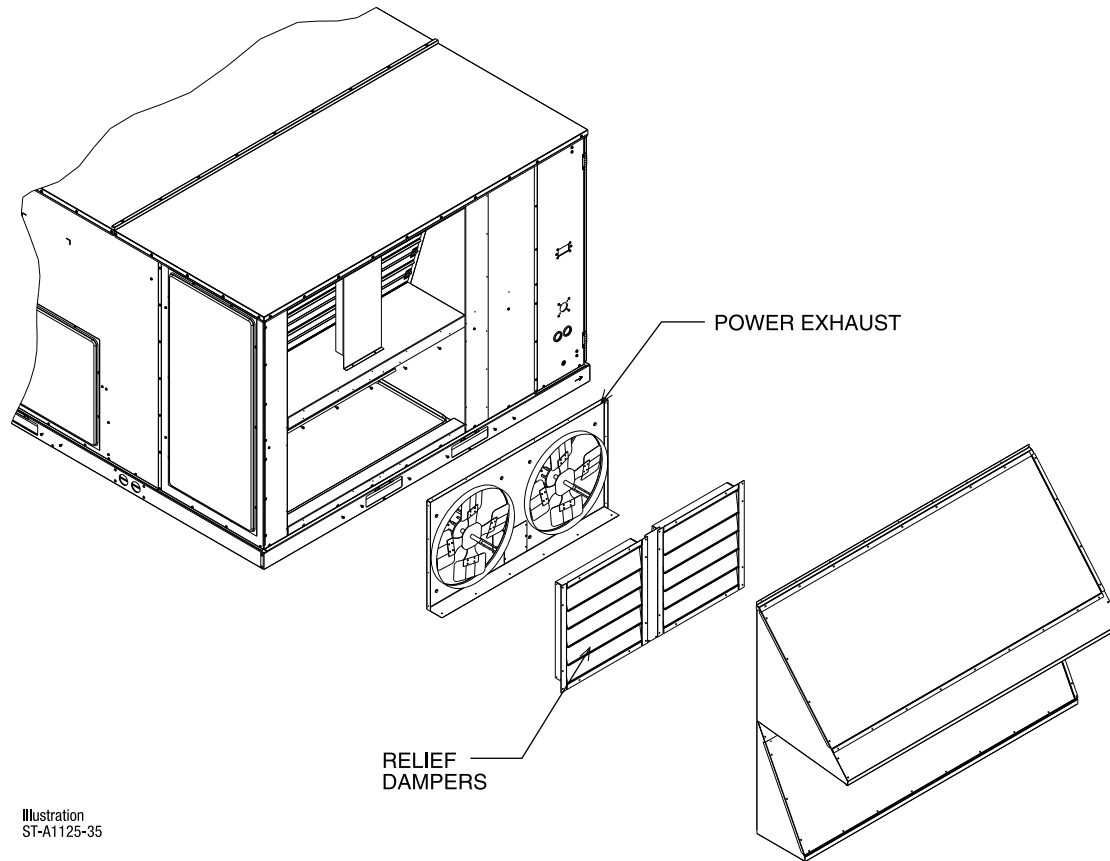

Illustration
ST-A1125-35

Model No.	No. of Fans	Volts	Phase	HP (ea.)	Low Speed		High Speed ^①		FLA (ea.)	LRA (ea.)
					CFM [L/s] ^②	RPM	CFM [L/s] ^②	RPM		
RXRX-BGF05C	2	208-230	1	0.75	4100 [1935]	850	5200 [2454]	1050	5	4.97
RXRX-BGF05D	2	460	1	0.75	4100 [1935]	850	5200 [2454]	1050	2.2	3.4
RXRX-BGF05Y	2	575	1	0.75	4100 [1935]	850	5200 [2454]	1050	1.5	2.84

NOTES: ① Power exhaust is factory set on high speed motor tap.

② CFM is per fan at 0" w.c. external static pressure.

[] Designates Metric Conversions

ROOFCURBS (Full Perimeter)

RXKG-CBH14

- One available height (14" [356 mm])
- Quick assembly corners for simple and fast assembly
- 1" [25.4 mm] x 4" [102 mm] Nailers provided
- Insulating panels not required because of insulated outdoor base pan
- Sealing gasket (28" [711 mm]) provided with Roofcurb
- Packaged for easy field assembly

TYPICAL INSTALLATION

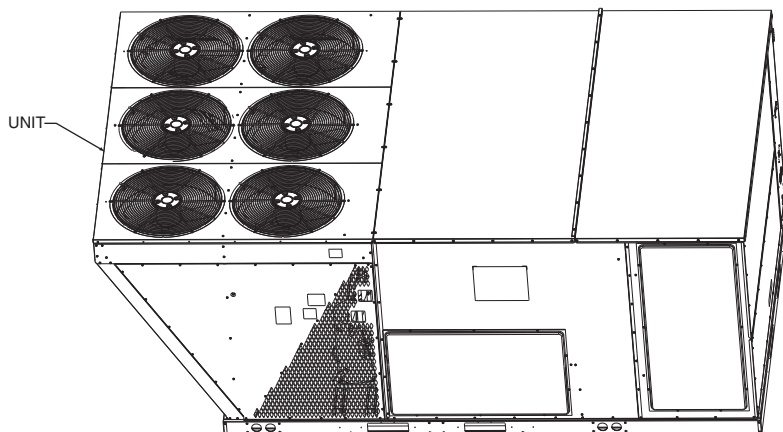

ROOFCURB ASSEMBLY

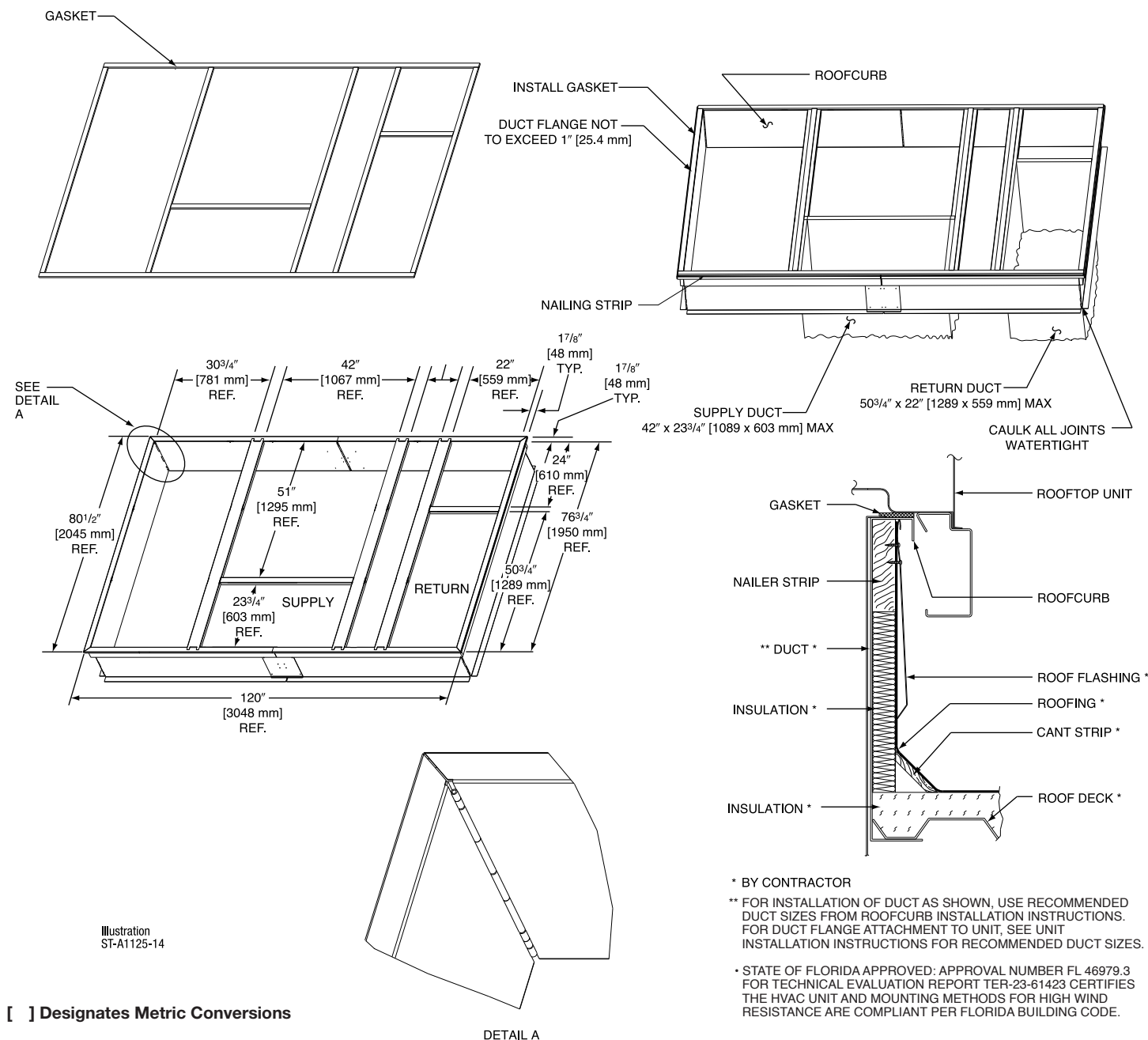

[] Designates Metric Conversions

Guide Specifications RGEHYB360

You may copy this document directly into your building specification. This specification is written to comply with the 2004 version of the "master format" as published by the Construction Specification Institute. www.csinet.org.

GAS HEAT PACKAGED ROOFTOP

HVAC Guide Specifications

Size Range: 30 Nominal Tons

1.00 General:

- A. Outdoor, rooftop mounted, electrically controlled, heating and cooling unit utilizing a(n) hermetic scroll compressor(s) for cooling duty and heat pump for heating duty.
- B. Factory assembled, single-piece heating and cooling rooftop unit. Contained within the unit enclosure shall be all factory wiring, piping, controls, and special features required prior to field start-up.
- C. Unit shall use environmentally safe, R-454B refrigerant.
- D. Unit shall be installed in accordance with the manufacturer's instructions.
- E. Unit must be selected and installed in compliance with local, state, and federal codes.
- F. Model and serial data shall be printed inside the control box.

1.01 Quality Assurance:

- A. Unit meets ASHRAE 90.1 2022 minimum efficiency requirements.
- B. Unit shall be rated in accordance with AHRI Standards 340/360.
- C. Unit shall be designed to conform to ASHRAE 15.
- D. Unit shall be UL-tested and certified in accordance with Standards and UL-listed and certified under Canadian standards as a total package for safety requirements.
- E. Insulation and adhesive shall meet NFPA 90A requirements for flame spread and smoke generation.
- F. Unit casing shall be capable of withstanding 500-hour salt spray exposure per ASTM B117 (scribed specimen).
- G. Roof curb shall be designed to conform to NRCA Standards.
- H. Unit shall be subjected to a completely automated run test on the assembly line. The data for each unit will be stored at the factory and must be available upon request.
- I. Unit shall be designed in accordance with UL Standard 60335-2-40 4th Edition. including tested to withstand rain.
- J. Unit shall be constructed to prevent intrusion of snow and tested to prevent snow intrusion into the control box up to 40 mph.

1.02 Manufacturer Qualifications

- A. Unit shall be designed in accordance with ISO 9001:2015 and shall be manufactured in a facility registered by ISO 9001:2015.

1.03 Installer Qualifications

- A. The installer shall be trained to install and service equipment with A2L refrigerants.

1.04 Delivery, Storage, and Handling:

- A. Unit shall be stored and handled per manufacturer's recommendations.
- B. Lifted by crane requires either shipping top panel or spreader bars.
- C. Unit shall only be stored or positioned in the upright position.

1.05 Unit Cabinet:

- A. Unit cabinet shall be constructed of galvanized steel and shall be coated with a baked enamel finish on all externally exposed surfaces.
- B. Unit cabinet exterior paint shall be: pre-painted steel with film thickness, (dry) 0.003 inches minimum, gloss (per ASTM D523, 60°F): 60, Hardness: H-2H Pencil hardness.
- C. The sheet-metal cabinet shall be constructed of 18-gauge material for structural components with an underlying coat of G90.
- D. Evaporator fan compartment interior cabinet insulation shall conform to AHRI Standards 340/360 minimum exterior sweat criteria. Interior surfaces shall be insulated with a minimum 3/4-in. thick, 1 lb density, flexible fiberglass insulation, foil faced on the air side.
- E. Shall utilize uniform screw sizing.
- F. Base of unit shall have a location for thru-the-base gas and electrical connections standard.
- G. Base Rail:
 - i. Unit shall have base rails on all sides.
 - ii. Holes shall be provided in the base rails for rigging shackles to facilitate maneuvering and overhead rigging.
 - iii. Holes shall be provided in the base rail for moving the rooftop for fork truck.
 - iv. Base rail shall be a minimum of 14 gauge thickness.

H. Condensate Pan and Connections:

- i. Shall be a sloped condensate drain pan made of a non-corrosive material and be removable for cleaning.
- ii. Shall comply with ASHRAE Standard 62.
- iii. Shall use a 1" – 1 1/2 NPT drain connection through either side of the drain pan. Connection shall be made per manufacturer's recommendations.
- iv. Shall be able to be easily removed.
- v. Shall be separate from the coil.

I. Top panel

- i. Shall be a single piece top panel over indoor section.

J. Gas Connections:

- i. All gas piping connecting to unit gas valve shall enter the unit cabinet at a single location on side of unit (horizontal plane).
- ii. Thru-the-base capability:
 - a. Standard unit shall have a thru-the-base gas-line location using a raised, embossed portion of the unit basepan.
 - b. No base pan penetration, other than those authorized by the manufacturer, is permitted.

K. Electrical Connections:

- i. All unit power wiring shall enter unit cabinet at a single, factory-prepared, knockout location.
- ii. Thru-the-base capability:
 - a. Standard unit shall have a thru-the-base electrical location(s) using a raised, embossed portion of the unit base pan.
 - b. No base pan penetration, other than those authorized by the manufacturer, is permitted.

L. Component access panels (standard):

- i. Cabinet panels shall be easily opened for servicing.
- ii. Stainless steel metal hinges are standard on all doors.
- iii. Panels covering control box, indoor fan, indoor fan motor, and electric or gas heater components (where applicable), shall have 1/4 turn latches.
- iv. 1/4 fasteners shall be permanently attached.

1.06 Operating Characteristics:

- A. Unit shall be capable of starting and running at 115°F (46°C) ambient outdoor temperature, meeting maximum load criteria of AHRI Standard 340/360 at ± 10% voltage.
- B. Compressor with standard controls shall be capable of operation down to 40°F (4°C), ambient outdoor temperatures. Low ambient accessory kit is necessary if mechanically cooling at ambient temperatures to 40°F (4°C).
- C. Unit shall discharge supply air vertically or horizontally as shown on contract drawings.
- D. Unit shall be factory configured for vertical supply & return configurations.
- E. Unit shall be field convertible from vertical to horizontal configuration.
- F. Unit shall be capable of mixed operation: vertical supply with horizontal return or horizontal supply with vertical return.

1.07 Electrical Requirements

- A. Main power supply voltage, phase, and frequency must match those required by the manufacturer.

1.08 Evaporator Fan Compartment:

- A. Interior cabinet surfaces shall be insulated with a minimum 3/4-in. thick, minimum 1 LB density, flexible fiberglass insulation bonded with foil face on the air side.
- B. Insulation and adhesive shall meet NFPA 90A requirements for flame spread and smoke generation.
- C. Insulation shall also be mechanically fastened with welded pin and retainer washer.

1.09 Thermostats

- A. Thermostat must:
 - i. Energize "G" when calling for heat.
 - ii. Have capability to energize 2 different stages of cooling, and 2 different stages of heating.
 - iii. Must include capability for occupancy scheduling.

1.10 Electronic Control System for HVAC:

- A. Shall be complete with self-contained low-voltage control circuit protected by a fuse on the 24-V transformer side
- B. Shall utilize color-coded wiring.
- C. Unit shall include a minimum of one 8-pin screw terminal connection board for connection of control wiring.
- D. Unit control board shall be provided with 7 segment readout via LCD display for status and diagnostics.

1.10.01 Safeties:

- A. Compressor over-temperature, over current.
- B. Standard Low-pressure switch:
 - i. Units shall have low pressure, loss of charge automatic reset device that will shut off compressor when tripped.
 - ii. Low pressure control
 - a. Provides active protection in both heating and cooling modes at all outdoor ambient temperatures. The low pressure control is an automatic reset type and opens at approximately 95 psig and closes at approximately 50 psig. Operation is slightly different between cooling and heating modes.
- C. Standard High-pressure switch:
 - i. Unit shall be equipped with high pressure switch device that will shut off compressor when tripped.
 - ii. High pressure control
 - a. The high pressure control is an automatic reset type and opens at approximately 610 psig and closes at approximately 420 psig. The compressor and fan motor will stop when the high pressure control opens and will start again if the high side pressure drops to approximately 420 psig where the automatic reset high pressure control resets. If the high pressure control opens 3 times within a particular call for heating or cooling operation, the defrost control will lock out compressor and outdoor fan operation.
- D. Automatic reset, motor thermal overload protector.
- E. The unit must be permanently grounded.
- F. Components are not compatible between different refrigerants. Do not use R-410A service equipment or components on R-454B equipment. System or part failure could occur.

1.11 Standard Filter Section:

- A. Shall consist of factory-installed, low velocity, throwaway 2-in. thick fiberglass filters of commercially available sizes.
- B. Unit will accept only 2 inch filters.
- C. Filter face velocity shall not exceed 365 fpm at nominal airflows.
- D. Filters shall be accessible through an access panel with “no-tool” removal as described in the unit cabinet section of the specification.
- E. Filters shall be held in place by a sliding filter tray, facilitating easy removal and installation.
- F. Filters access is specified in the unit cabinet section of this specification.

1.12 Coils:

- A. Standard Aluminum/MicroChannel Condenser Coils:
 - i. Standard condenser coils shall be aluminum.
 - ii. Condenser coils shall be leak tested to 150 psig, pressure tested to 400 psig, and qualified to burst test at 2,200 psi.
- B. Standard Aluminum/Copper Evaporator Coils:
 - i. Standard evaporator coils shall have aluminum lanced plate fins mechanically bonded to seamless internally grooved copper tubes with all joints brazed.
 - ii. Evaporator coils shall be leak tested to 150 psig, pressure tested to 550 psig and qualified to UL 1995 burst test at 2,200 psig.

1.13 Refrigerant Components:

- A. Refrigerant circuit shall include the following control, safety, and maintenance features:
 - i. Thermal Expansion Valve (TXV) with orifice type distributor.
 - ii. Refrigerant filter drier.
 - iii. External service gauge connections to unit suction and discharge lines.
 - iv. Pressure gauge access through an access port in the front and rear panel of the unit.
 - v. External gauge ports shall be lockable.
- B. Compressors:
 - i. Unit shall use one fully hermetic, scroll compressor for each independent refrigeration circuit.
 - ii. Compressor motors shall be cooled by refrigerant gas passing through motor windings.
 - iii. Compressors shall be internally protected from high discharge temperature conditions. Advanced Scroll Temperature Protection on 240-300 sizes.
 - iv. Compressors shall be protected from an over-temperature and over-amperage conditions by an internal, motor overload device.
 - v. Compressor shall be factory mounted on rubber grommets.
 - vi. Compressor motors shall have internal line break thermal and current overload protection.
 - vii. Crankcase heaters shall not be required for normal operating range.
 - viii. Compressor shall have molded electrical plug.

1.14 Evaporator Fan and Motor:

- A. Evaporator fan motor:
 - i. Shall have permanently lubricated bearings
 - ii. Shall have inherent automatic-reset thermal overload protection.
 - iii. Shall have a maximum continuous bhp rating for continuous duty operation; no safety factors above that rating shall be required.
- B. Direct Drive Evaporator Fan:
 - i. Belt drive shall include an adjustable-pitch motor pulley.
 - ii. Shall use sealed, permanently lubricated ball-bearing type.
 - iii. Blower fan shall be double-inlet type with forward-curved blades.
 - iv. Shall be constructed from steel with a corrosion resistant finish and dynamically balanced.
- C. Blower Assembly:
 - i. Entire assembly shall be able to slide out completely.
 - ii. Shall be able to slide-out without the removal of the roof and condenser fan motors.

1.15 Condenser Fans and Motors:

- A. Condenser fan motors:
 - i. Shall be a totally enclosed motor.
 - ii. Shall use permanently lubricated bearings.
 - iii. Shall have inherent thermal overload protection with an automatic reset feature.
 - iv. Shall use a shaft-down design. Shaft-up designs including those with “rain-slinger devices” shall not be allowed.
- B. Condenser Fans shall:
 - i. Shall be a direct-driven propeller type fan
 - ii. Shall have blades riveted to corrosion-resistant steel spiders and shall be dynamically balanced.

1.16 RTU-C Controller:

- A. Shall be ASHRAE 62-2001 compliant.
- B. Shall accept 18-32VAC input power.
- C. Shall have an operating temperature range from -40°F (-40°C) to 158°F (70°C), 10%– 95% RH (non-condensing).
- D. Controller shall accept the following inputs: space temperature, setpoint adjustment, outdoor air temperature, indoor air quality, outdoor air enthalpy, fire shutdown, return air enthalpy, fan status, remote time clock/door switch.
- E. Shall accept a CO₂ sensor in the conditioned space and be Demand Control Ventilation (DCV) ready.
- F. Shall provide the following outputs: Economizer, fan, cooling stage 1, cooling stage 2, heat stage 1, heat stage 2, exhaust, occupied.
- G. Unit shall provide surge protection for the controller through a circuit breaker.
- H. Shall have a field-installed communication card allowing the unit to be able to communicate at a Baud rate of 19.2K or faster.
- I. Shall have an LED display independently showing the status of activity on the communication bus, and processor operation.
- J. Optional field-installed BACnet plug-in communication card which includes an EIA-485 protocol communication port, or an optional field-installed LonWorks plug-in communications card.
- K. Software upgrades will be accomplished by local download. Software upgrades through chip replacements are not allowed.
- L. Shall be shock resistant in all planes to 5G peak, 11ms during operation, and 100G peak, 11ms during storage.
- M. Shall be vibration resistant in all planes to 1.5G @ 20-300 Hz.
- N. Shall support a bus length of 4000 ft max, 60 devices per 1000 ft section, and 1 RS-485 repeater per 1000 ft sections.

1.17 Open Protocol, Direct Digital Controller:

- A. Shall be ASHRAE 62-2001 compliant.
- B. Shall accept 18-30VAC, 50-60Hz, and consumer 15VA or less power.
- C. Shall have an operating temperature range from -40°F (-40°C) to 130°F (54°C), 10% - 90% RH (non-condensing).
- D. Shall have either a field-installed BACnet plug-in communication card which includes an EIA-485 protocol communication port, or a field-installed LonWorks plug-in communications card.
- E. The BACnet plug in communication card shall include built-in protocol for BACnet (MS/TP and PTP modes)
- F. The LonWorks plug in communication card shall include the Echelon processor required for all Lon applications.
- G. Shall allow access of up to 62 network variables (SNVT). Shall be compatible with all open controllers

- H. Baud rate Controller shall be selectable through the EIA-485 protocol communication port.
 - I. Shall have an LED display independently showing the status of serial communication, running, errors, power, all digital outputs, and all analog inputs.
- J. Shall accept the following inputs: space temperature, setpoint adjustment, outdoor air temperature, indoor air quality, outdoor air enthalpy, compressor lock-out, fire shutdown, enthalpy switch, and fan status/filter status/humidity/remote occupancy.
- K. Shall provide the following outputs: economizer, fan, cooling stage 1, cooling stage 2, heat stage 1, heat stage 2, exhaust.
- L. Software upgrades will be accomplished by either local or remote download. No software upgrades through chip replacements are allowed.
- M. Shall be natively equipped with Modbus communication protocol.

1.18 Adjustable Frequency Drive:

- A. Unit shall be supplied with an electronic variable frequency drive for the supply air fan.
- B. Drive shall be factory installed in an enclosed cabinet.
- C. Drive shall meet UL Standard 60335-2-40 4th Edition.
- D. The completed unit assembly shall be UL listed.
- E. Drives are to be accessible through a tooled access hinged door assembly.
- F. The unit manufacturer shall install all power and control wiring.
- G. The supply air fan drive output shall be controlled by the factory installed main unit control system and drive status and operating speed shall be monitored and displayed at the main unit control panel.
- H. Drive shall be programmed, and factory run tested in the unit.

1.19 Gas Heat:

- A. Shall have standard two stage gas heat.
- B. Heat exchanger shall be an induced draft design. Positive pressure heat exchanger designs shall not be allowed.
- C. Shall incorporate a direct-spark ignition system and redundant main gas valve.
- D. Heat exchanger design shall allow combustion process condensate to gravity drain; maintenance to drain the gas heat exchanger shall not be required.
- E. Gas supply pressure at the inlet to the rooftop unit gas valve must match that required by the manufacturer.
- F. The heat exchanger shall be controlled by the Core Command microprocessor.
 - i. The Core Command board shall notify users of fault using two 7 segment displays.
- G. Standard Heat Exchanger construction:
 - i. Heat exchanger shall be of the tubular-section type constructed of a minimum of 20-gauge steel coated with a nominal 1.2 mil aluminum-silicone alloy for corrosion resistance.
 - ii. Burners shall be of the in-shot type constructed of aluminum-coated steel.
 - iii. Burners shall incorporate orifice for rated heat output up to 2,000 ft. (610m) elevation with a gas heating valve of 1050. Alternate orifices may be required depending on local gas heating valves and elevations.
 - iv. Each heat exchanger tube shall contain restrictions similar to dimples for increased heating effectiveness.
- H. Optional Stainless Steel Heat Exchanger construction:
 - i. Use energy saving, direct-spark ignition system.
 - ii. Use a redundant main gas valve.
 - iii. Burners shall be of the in-shot type constructed of aluminum-coated steel.
 - iv. All gas piping shall enter the unit cabinet at a single location on side of unit (horizontal plane).
 - v. The optional stainless steel heat exchanger shall be of the tubular-section type, constructed of a minimum of 20-gauge type 409 stainless steel.
 - vi. Type 409 stainless steel shall be used in heat exchanger tubes.
 - vii. Complete stainless steel heat exchanger allows for greater application flexibility.
- I. Induced draft combustion motor and blower:
 - i. Shall be a direct-drive, single inlet, forward-curved centrifugal type.
 - ii. Shall be made from steel with a corrosion-resistant finish.
 - iii. Shall be permanently lubricated sealed bearings.
 - iv. Shall have inherent thermal overload protection.
 - v. Shall have an automatic reset feature.

1.20 Special Features:

A. Integrated Economizers:

- i. Integrated, gear-driven parallel modulating blade design type capable of simultaneous economizer and compressor operation.
- ii. Independent modules for vertical or horizontal return configurations shall be available. Vertical return modules shall be available as a factory installed option.
- iii. Damper blades shall be galvanized steel with metal gears. Plastic or composite blades on intake or return shall not be acceptable.
- iv. Shall include all hardware and controls to provide free cooling with outdoor air when temperature and/or humidity are below setpoints.
- v. Shall be equipped with gear driven dampers for both the outdoor ventilation air and the return air for positive air stream control.
- vi. Shall be equipped with low-leakage dampers, not to exceed 2% leakage at 1 in. wg pressure differential.
- vii. Shall be capable of introducing up to 100% outdoor air.
- viii. Shall be equipped with a barometric relief damper capable of relieving up to 100% return air.
- ix. Shall be designed to close damper(s) during loss-of-power situations with spring return built into motor.
- x. Enthalpy sensor shall be provided as standard. Outdoor air sensor set point shall be adjustable and shall range enthalpy equivalent of 63°F @ 50% RH to 73°F @ 50% RH. Additional sensor options shall be available as accessories.
- xi. The economizer controller shall also provide control of an accessory power exhaust unit function. Factory set at 70%, with a range of 0% to 100%.
- xii. The economizer shall maintain minimum airflow into the building during occupied period and provide design ventilation rate for full occupancy. A remote potentiometer may be used to override the damper set point.
- xiii. Dampers shall be completely closed when the unit is in the unoccupied mode.
- xiv. Economizer controller shall accept a 2-10Vdc CO₂ sensor input for IAQ/DCV control. In this mode, dampers shall modulate the outdoor-air damper to provide ventilation based on the sensor input.
- xv. Compressor lockout sensor on the unit controller is factory set at 35°F and is adjustable from 30°F (-1°C) to 50°F (10°C) and resets the cooling lockout at 5°F (+2.7°C) above the set point.
- xvi. Actuator shall be direct coupled to economizer gear. No linkage arms or control rods shall be acceptable.
- xvii. Economizer controller shall provide indications when in free cooling mode, in the DCV mode, or the exhaust fan contact is closed.
- xviii. Economizer wire harness will have provision for smoke detector.
- xix. Shall provide fault detection and diagnostics (FDD) system in accordance with local code. Faults shall be communicated out on an alarm signal.

B. Two-Position Motorized Damper:

- i. Damper shall be a Two-Position Motorized Damper. Damper travel shall be from the full closed position to the field adjustable %-open setpoint.
- ii. Damper shall include adjustable damper travel from 25% to 100% (full open).
- iii. Damper shall include single or dual blade, gear driven dampers and actuator motor.
- iv. Actuator shall be direct coupled to damper gear. No linkage arms or control rods shall be acceptable.
- v. Damper will admit up to 100% outdoor air for applicable rooftop units.
- vi. Damper shall close upon indoor (evaporator) fan shutoff and/or loss of power.
- vii. The damper actuator shall plug into the rooftop unit's wiring harness plug. No hard wiring shall be required.
- viii. Outside air hood shall include aluminum water entrainment filter

C. Manual Damper

- i. Manual damper package shall consist of damper, air inlet screen, and rain hood which can be preset to admit up to 50% outdoor air for year-round ventilation.

D. Head Pressure Control Package

- i. Controller shall control coil head pressure by condenser-fan cycling.

E. Liquid Propane (LP) Conversion Kit

- i. Package shall contain all the necessary hardware and instructions to convert a standard natural gas unit for use with liquefied propane, up to 2000 ft (610m) elevation.

F. Condenser Coil Hail Guard Assembly:

- i. Shall protect against damage from hail.
- ii. Shall be louvered style.

- G. Unit-Mounted, Non-Fused Disconnect Switch:
- i. Switch shall be factory-installed, internally mounted.
 - ii. National Electric Code (NEC) and UL approved non-fused switch shall provide unit power shutoff.
 - iii. Shall be accessible from outside the unit.
 - iv. Shall provide local shutdown and lockout capability.
- H. Convenience Outlet:
- i. Non-Powered convenience outlet.
 - ii. Outlet shall be powered from a separate 115V-120V power source.
 - iii. A transformer shall not be included.
 - iv. Outlet shall be field-installed and internally mounted with easily accessible 115V female receptacle.
 - v. Outlet shall include 15-amp GFI receptacle with independent fuse protection.
 - vi. Outlet shall be accessible from outside the unit.
- I. Fan/Filter Status Switch:
- i. Switch shall provide status of indoor evaporator fan (ON/OFF) or filter (CLEAN/DIRTY).
 - ii. Status shall be displayed either over communication bus (when used with direct digital controls) or through the controller LCD display inside the unit control box.
- J. Flue Discharge Deflector:
- i. Flue discharge deflector shall direct unit exhaust vertically instead of horizontally.
 - ii. Deflector shall be defined as a "natural draft" device by the National Fuel and Gas (NFG) code.
- K. Propeller Power Exhaust:
- i. Power exhaust shall be used in conjunction with an integrated economizer.
 - ii. Independent modules for vertical or horizontal return configurations shall be available.
 - iii. Horizontal power exhaust shall be mounted in return ductwork.
 - iv. Power exhaust shall be controlled by economizer controller operation. Exhaust fans shall be energized when dampers open past the 0-100% adjustable setpoint on the economizer control.
 - v. Capable of adjustable but constant volume.
- L. Roof Curbs (Vertical):
- i. Full perimeter roof curb with exhaust capability providing separate air streams for energy recovery from the exhaust air without supply air contamination.
 - ii. Formed galvanized steel with wood nailer strip and shall be capable of supporting entire unit weight.
 - iii. Permits installation and securing of ductwork to curb prior to mounting unit on the curb.
- M. High-Static Indoor Fan Motor(s) and Drive(s)
- i. High-static motor(s) and drive(s) shall be factory-installed to provide additional performance range.
- N. Universal Gas Conversion Kit
- i. Package shall contain all the necessary hardware and instructions to convert a standard natural gas unit to operate from 2000-7000 ft (610 to 2134m) elevation with natural gas or from 0-7000 ft (90-2134m) elevation with liquefied propane.
- O. Outdoor Air Enthalpy Sensor
- i. The outdoor air enthalpy sensor shall be used to provide single enthalpy control. When used in conjunction with a return air enthalpy sensor, the unit will provide differential enthalpy control. The sensor allows the unit to determine if outside air is suitable for free cooling.
- P. Return Air Enthalpy Sensor
- i. The return air enthalpy sensor shall be used in conjunction with an outdoor air enthalpy sensor to provide differential enthalpy control.
- Q. Indoor Air Quality (CO₂) Sensor:
- i. Shall be able to provide demand ventilation indoor air quality (IAQ) control.
 - ii. The IAQ sensor shall be available in duct mount, wall mount, or wall mount with LED display. The set point shall have adjustment capability.

R. Smoke Detectors:

- i. Shall be a Four-Wire Controller and Detector.
- ii. Shall be environmentally compensated with differential sensing for reliable, stable, and drift-free sensitivity.
- iii. Shall use magnet-activated test/reset sensor switches.
- iv. Shall have a recessed momentary switch for testing and resetting the detector.
- v. Controller shall include:
 - a. One set of normally open alarm initiation contacts for connection to an initiating device circuit on a fire alarm control panel
 - b. Two Form-C auxiliary alarm relays for interface with rooftop unit or other equipment
 - c. One Form-C supervision (trouble) relay to control the operation of the Trouble LED on a remote test/reset station
 - d. Capable of direct connection to two individual detector modules.
 - e. Can be wired to up to 14 other duct smoke detectors for multiple fan shutdown applications.

S. Barometric Relief:

- i. Shall include damper, seals, hard-ware, and hoods to relieve excess building pressure.
- ii. Damper shall gravity-close upon shutdown.
- iii. Only available with an economizer. Barometric relief is not available as a stand-alone accessory.

T. Time Guard:

- i. Shall prevent compressor short cycling by providing a 5-minute delay (± 2 minutes) before restarting a compressor after shutdown for any reason.
- ii. One device shall be required per compressor.

U. Factory Installed Overflow Switch

- i. Switch shall monitor the condensate level in drain pan and stops compression operation when overflow conditions occur

V. Access Panels:

- i. Hinges with $\frac{1}{4}$ turn fasteners shall be permanently attached.
- ii. Hinges shall be powder coated and made from stainless steel.

W. Electric Heat

- i. Heating Section:
 - a. Heater element open coil resistance wire, nickel-chrome alloy, strung through ceramic insulators mounted on metal frame. Coil ends are staked and welded to terminal screw slots.
 - b. Heater assemblies are provided with integral fusing for protection of internal heater circuits not exceeding 48 amps each. Auto reset thermostat limit controls, magnetic heater contactors (24V coil) and terminal block all mounted in electric heater control box (minimum 18 gauge galvanized steel) attached to end of heater assembly.

X. Refrigerant Detection System:

- i. In the event of a detected refrigerant leak, the refrigerant leak detection sensor will trigger the mitigation procedure that shuts off the compressor(s) and turns on the indoor blower motor.
- ii. In the event of a detected refrigerant leak, the system will display fault code 'A2L Event' will appear on the LCD module.



engineered for life™

GENERAL TERMS OF LIMITED WARRANTY*

Rheem will furnish a replacement for any part of this product which fails in normal use and service within the applicable periods stated, in accordance with the terms of the limited warranty.

Compressor

Commercial Applications.....Five (5) Years

Parts

Commercial Applications.....One (1) Year

Factory Standard Heat Exchanger

Commercial ApplicationsTen (10) Years

Stainless Steel Heat Exchanger

Commercial Applications.....Twenty (20) Years

***For complete details of the Limited and Conditional Warranties, including applicable terms and conditions, contact your local contractor or the Manufacturer for a copy of the product warranty certificate.**

Before proceeding with installation, refer to installation instructions packaged with each model, as well as complying with all Federal, State, Provincial, and Local codes, regulations, and practices.

© 2026 Rheem Manufacturing Company. Trademarks are property of their respective owners.

In keeping with its policy of continuous progress and product improvement, manufacturer reserves the right to make changes without notice.

5600 Old Greenwood Road
Fort Smith, Arkansas 72908 • Rheem.com

125 Edgeware Road, Unit 1
Brampton, Ontario • L6Y 0P5 • Rheem.ca