

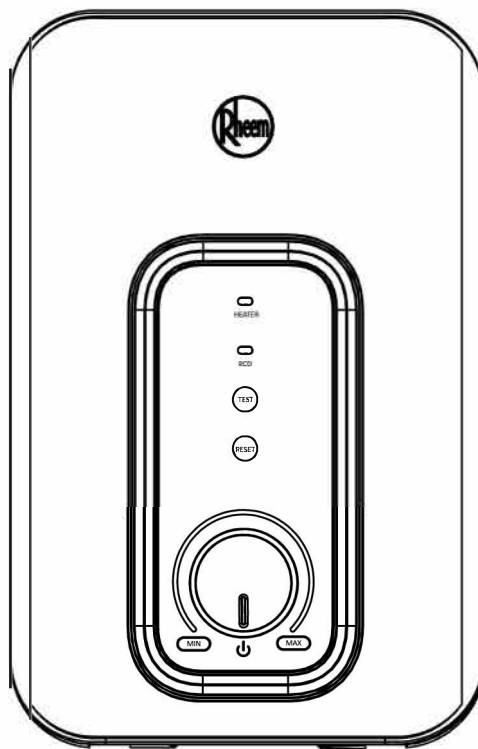

Instant Water Heaters Instruction Manual



Rheem RH-188 Series

An ISO 9001 Certified Manufacturer

	Pages
1. Matrix List	2
2. Introduction	3
3. Important Safety Information	4
4. Part Contents Checklist	5
5. Parts Description	6 - 7
6. Electrical Requirements	8
7. Water Requirements	9
8. Installation	10 - 11
9. Fitting Your Shower set	12
10. Commissioning	13 - 14
11. Operating the Shower	15
12. User maintenance	16
13. Troubleshooting	17
14. Specification	18 - 19

Matrix List

2

Model	Rated	RCD	Country
RH-188-N	240V, 50/60Hz 3.6kW 3.8kW 4.2kW	No	Malaysia
RH-188-R1		Single Relay RCD	
RH-188-R2		Double Relay RCD	
RH-188-N	230V, 50/60Hz 3.3kW 3.5kW	No	Singapore
RH-188-R1		Single Relay RCD	
RH-188-R2		Double Relay RCD	
RH-188-N	220V, 50/60Hz 3.5kW 4.5kW 5.5kW	No	Thailand/ Cambodia/ Myanmar/ Philippines
RH-188-R1		Single Relay RCD	
RH-188-R2		Double Relay RCD	

Congratulations!

Thank you for making excellent choice by purchasing the **RHEEM Electric water heater**.

Please read these instructions carefully for optimum performance, necessary fitting and operating instructions.

Your **RHEEM Heater** has been manufactured in a

ISO9001 registered company which provides you with assurances of its quality safety and environmental friendly.

Caution!

Read all of these instructions and retain this guide for later use.

Pass on this guide in the event of change of ownership of the installation site.

Follow all warnings, cautions and instruction contained in this guide, and on or inside appliance.

Anyone who may have difficulty understanding or operating the controls of any shower should be attended whilst showering. Particular consideration should be given to the young, the elderly, the infirm, or anyone inexperienced in the correct operation of the controls as well as children should be supervised to ensure that they do not play with the appliance.

When this appliance has reached the end of its serviceable life, it should be disposed of in a safe manner, in accordance with current local authority recycling or waste disposal policy.

WARNING: This appliance is not to be used for a portable water supply.

1. Warning!

1.1. Products manufactured by us are safe and without risk provided they are installed, used and maintained in good working order in accordance with our instructions and recommendations.

1.2. THIS APPLIANCE MUST BE EARTHED.

Earthing Requirement:

The Earthing installation should be carried out in accordance with the local Wiring Regulations. **Where EARTHING of the premises is not evident, it is necessary to run an EARTH CONDUCTOR and solidly connect an earth rod local to the installation.** The following notes are for guidance only:

- 1.2.1 Select a damp place to bury the earth rod.
- 1.2.2 Connect earth conductor of minimum 2.5mm² (7/0.67mm) to the appliances Earth (⊕) terminal. Connect other end of the earth conductor to the earth rod.
- 1.2.3 Check to ensure earthing resistance is less than 100Ω. It may be necessary to drive two or more rods and connect them together to achieve a satisfactory results.
- 1.2.4 Installation of earth rod must be carried out by a registered and certified wiring contractor.

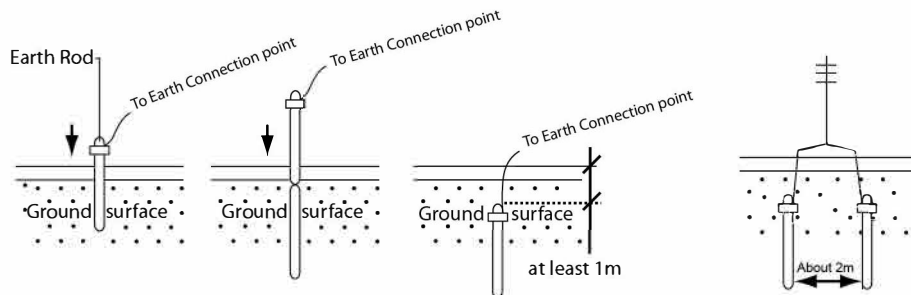

- 1.3. **DO NOT** allow the unit to be run dry.
- 1.4. **DO NOT** fit any form of outlet flow control as the outlet acts as a vent for the tank body. Once recommended outlet fittings should be used.
- 1.5. There are no user serviceable components beneath the cover of this appliance. Only a competent tradesperson should remove the cover.
- 1.6. If the cover is not correctly fitted and water has entered the case. Isolate the electrical and water supply before removing the cover.
- 1.7. Mains connections are exposed when the cover is removed.
- 1.8. Refer to the wiring diagram before making any electrical connections.
- 1.9. Ensure all electrical connections are tight, to prevent overheating.

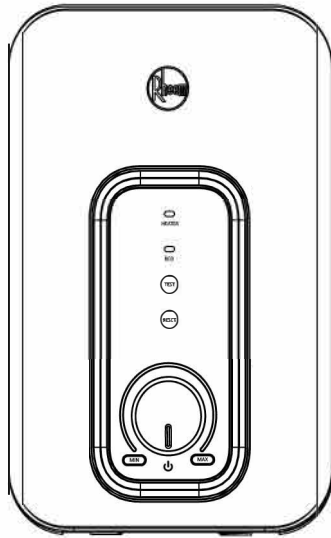

1 x Rheem Unit

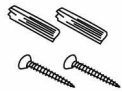

2 x Wall Plug & Screw Set

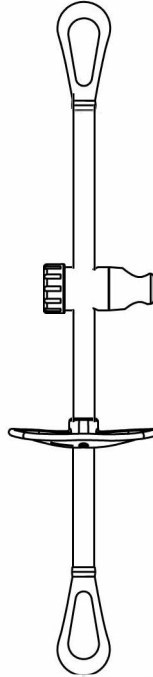

1 x Sliding Rail

1 x Shower Holder

1 x Soap Tray

Rail Support c/w
4 x Screw & Wall Plug Set

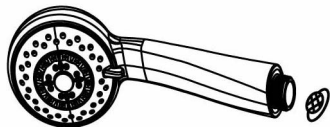

1 x Handshower
c/w filter mesh washer

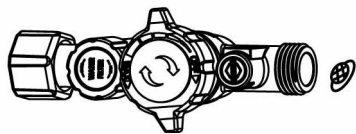

MH Stop Valve with Regulator
c/w 1pcs washer

1 x Flexible Hose
c/w 2 pcs washer

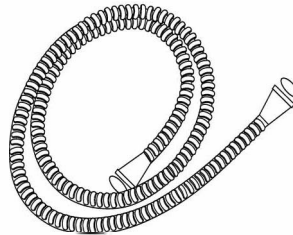

MODEL: RHEEM RH-188-N
 RHEEM RH-188-R1
 RHEEM RH-188-R2

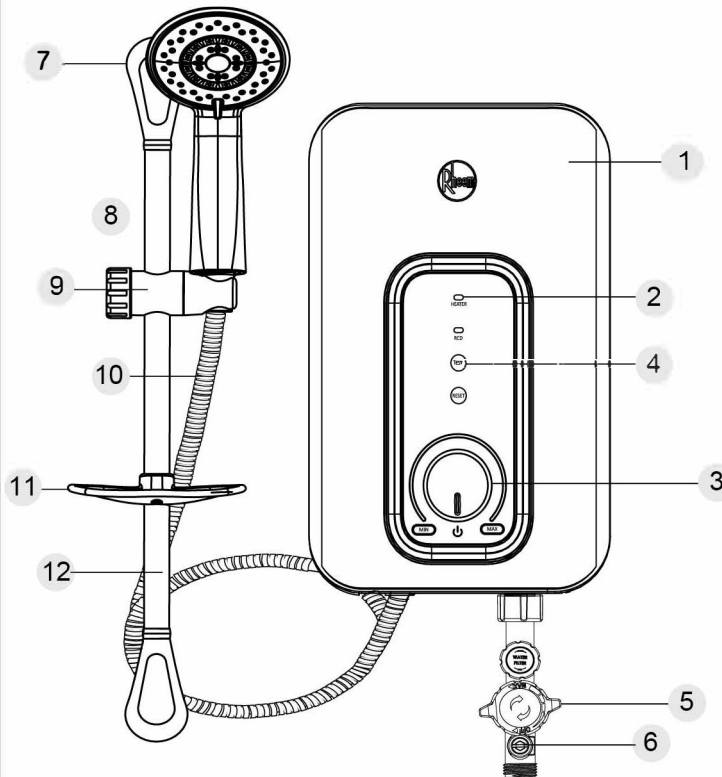

1. Heater Cover
2. Indicator Lights
3. Power Control Knob
4. RCD Test Reset Button (for RCD Model Only)
5. Stop Valve
6. Regulator Valve
7. Rail Support (2Nos)
8. Handshower
9. Shower Holder
10. Flexible Hose
11. Rotatable Soap Dish
12. Sliding Rail

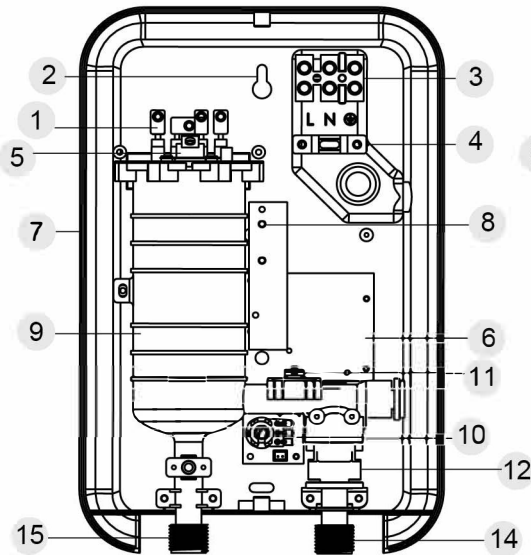

RH-188-N

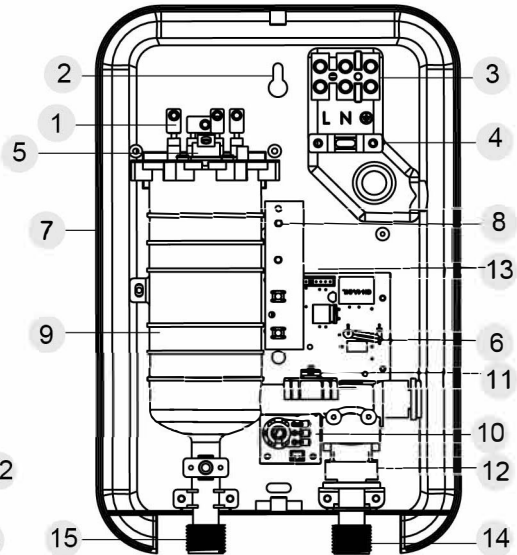

RH-188-R1

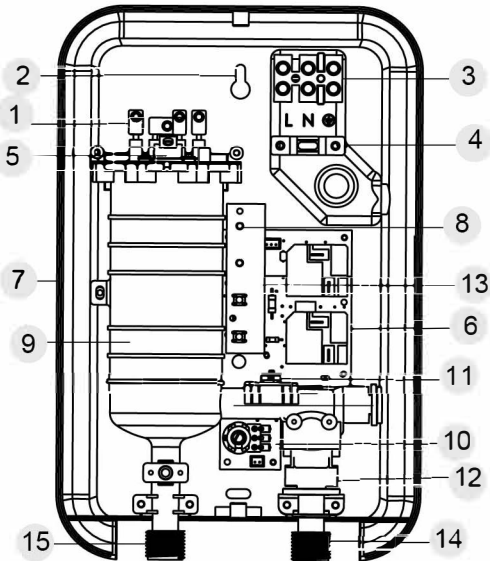

RH-188-R2

1. Heating Element
2. Mounting Holes
3. Terminal Block
4. Cable Entry
5. Thermostat
6. Parvus PCB assembly
7. Heater Base
8. Indicator Light
9. Water Tank
10. Electronic Control
11. Triac
12. Flow Switch Assembly
13. RCD TEST RESET Board
(for RCD model only)
14. Water Inlet
15. Water Outlet

**WARNING
THIS APPLIANCE MUST BE EARTHED**

Installation must be carried out by a qualified Electrician. The Current carrying capacity of the cable must be at least that of the shower circuit protection. (See table).

Cable Sizes Table

Country	Voltage (V~)	Power (kW)	Amperes (A)	Cable Size (mm ²)	Fuse / MCB (A)	ON / OFF Switch (A)
Malaysia	240V ~ 50/60Hz	3.8	15.0	4.0	20	20
Singapore	230V ~ 50/60Hz	3.3	14.4	4.0	16	20
Cambodia & Myanmar	220V ~ 50/60Hz	3.5	15.9	4.0	20	20
Philippines & Vietnam		4.5	20.5	4.0	30 / 32	30 / 32
Thailand		5.5	25.0	4.0	30 / 32	30 / 32

The shower must be connected to its own independent electrical circuit.

Lead the power cable from the indoor fuse distributor board or Miniature Circuit Breaker (MCB) to a 10mA RCD and from RCD to 'ON/OFF' Double -Pole switch outside the bathroom. Please refer to Bathroom General Wiring layout below.

The water heater must be permanently connected to the electricity-supply through a double-pole linked switch having a contact separation of at least 3mm in all poles Incorporated in the fixed wiring. This switch must be out of reach of a person using a shower. The use of a plug and socket is not recommended.

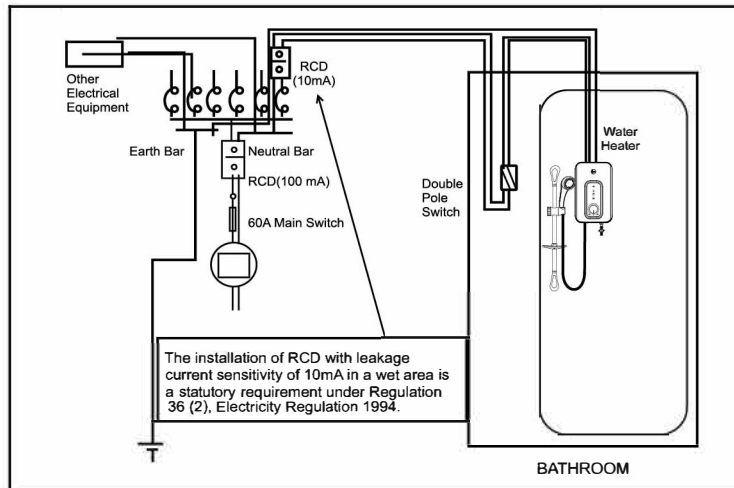

Plumbing Schematic Diagram

An electric water heater can be fitted in your home regardless of the type of plumbing system as in most cases they can operate directly off the mains cold water supply.

Fig. shows a typical system layout. Do not use jointing compounds on any pipe fittings for the installation.

The Unit works at minimum water flow rate of 2 litre/min.

SITING OF THE SHOWER

WARNING: The shower must not be positioned where it will be subjected to freezing conditions.

FOR EASE OF SERVICING, THE UNIT MUST ALWAYS BE MOUNTED ON THE SURFACE OF TILED WALLS. NEVER TILE UP TO THE UNIT.

This product is splash-proof rated and is approved for use in shower cubicles and over baths.

However, do not install the unit in a position where the sprayhead will consistently direct water over it.

The shower unit **MUST** be positioned vertically.

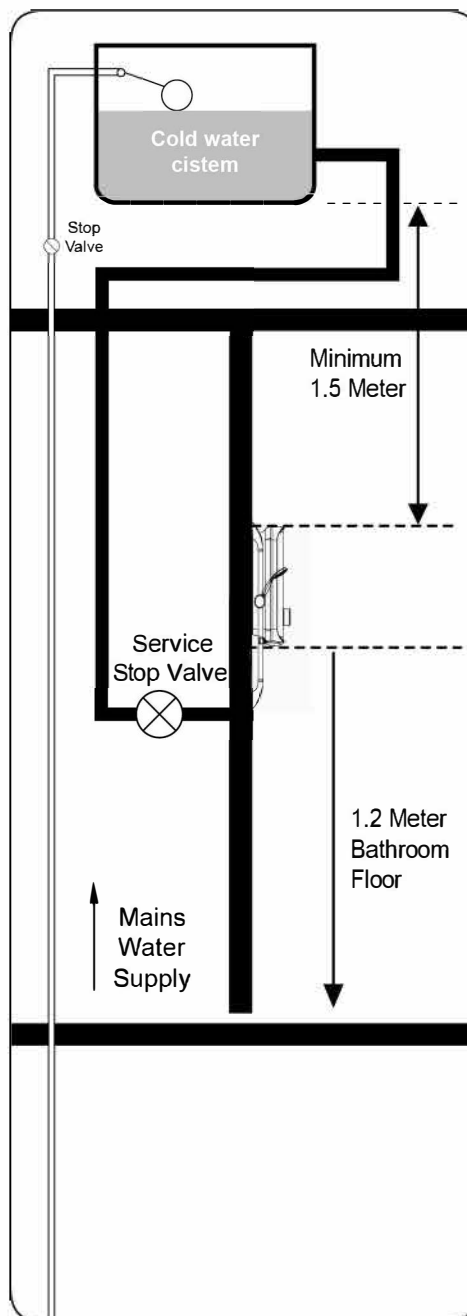

FIXING THE SHOWER TO THE WALL

Important: The shower must be mounted on a flat surface which covers the full width and length of the backplate. It is important that the wall surface is flat otherwise difficulty may be encountered when fitting the cover and subsequent.

1.1 Decide on a suitable position to allow for cover fit and removal.

Determine the direction that you require the inlet water supply and electrical cable to enter the unit from.

Determine the height at which you require the unit to be installed.

1.2 Unscrew the cover retaining screws sufficient to remove the cover.

Note! The cover retaining screws are captive and should remain in the case.

1.3 Remove the cover.

Mark the position of the unit on the wall. Mark the positions of the fixing holes. Make sure that sufficient electrical Supply cable is available for connection to the terminal block.

1.4 Drill and plug the fixing holes. Secure the unit to the wall with the screws provided. Avoid drilling into any supply cable/pipe.

Note! Hook the backplate over the top screws and fit the lower fixing screw into position. **DO NOT** fully tighten the screws at this stage, as the fixing holes are elongated to allow for out of square adjustment after the plumbing connections have been completed.

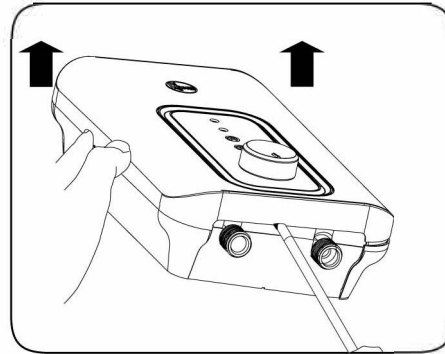

Remove the Cover

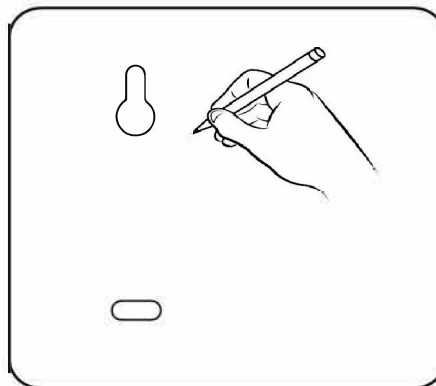

Mark the mounting holes

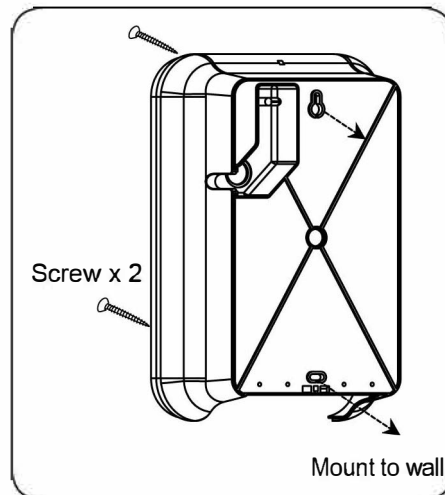

PLUMBING CONNECTIONS

COMPLETE THIS PROCESS BEFORE WIRING CONNECTION

CONNECTION PROCEDURE:

Connect the water supply to the inlet of the shower via 15mm copper, stainless steel or plastic pipe using a 15mm x 15mm elbow compression fitting.

Do not use excessive force when making these connections.

FITTING THE STOP VALVE

Feed the Stop valve by screwing to the unit Inlet.

Note:

Ensure the supplied washers are in place before connecting inlet and the Stop Valve.

Fit the other point of Stop Valve to the incoming water supply.

Ensure that the backplate of the unit is flat on the wall and positioned squarely. Tighten the fixing screws.

Turn on the water supply and check for leaks in the pipework connection to the shower.

NOTE: At this stage no water can flow through the unit.

ELECTRICAL CONNECTION

WARNING: THIS UNIT MUST BE EARTHED.

SWITCH OFF THE ELECTRICITY SUPPLY.

The cable entry points are shown in the figure below. Determine the cable entry to the unit.

a) Side entry – Poke the electrical cable through the rubber grommet (Fig. 1).

OR

b) Rear entry - Poke the electrical cable through the rubber grommet (Fig. 2)

Route the cable into the shower unit and connect to the terminal block (fig. 1) as follows:-

Earth cable to terminal marked '⊕'

Neutral cable to terminal marked 'N'

Live cable to terminal marked 'L'

IMPORTANT: Fully tighten the terminal block screws and ensure that no cable insulation is trapped under the screws. Loose connections can result in cabling overheating. DO NOT switch on the electricity supply until the cover has been fitted.

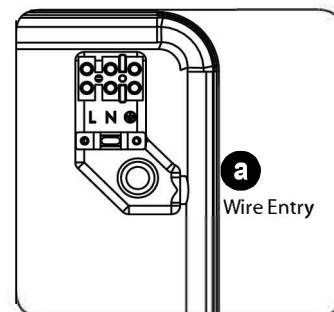
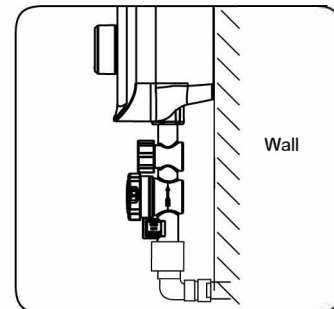
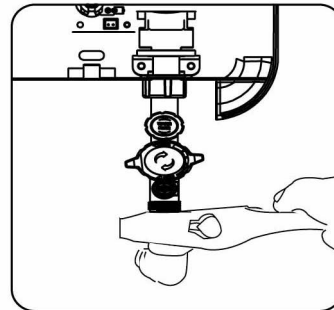

Side entry / Fig. 1

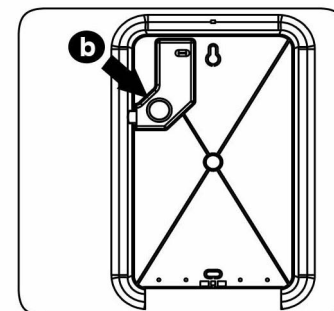

Rear entry / Fig. 2

FITTING THE HOSE AND SPRAY HEAD

Fit the flexible hose by screwing to the unit outlet (Left side) and sprayhead ensuring the supplied washer are in place at the outlet and the Washer at the sprayhead

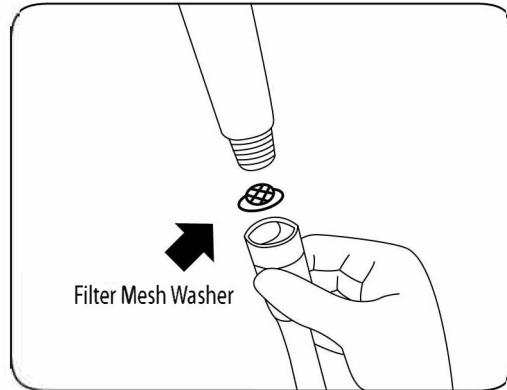

Place the sprayhead into the holder and check that it fits correctly

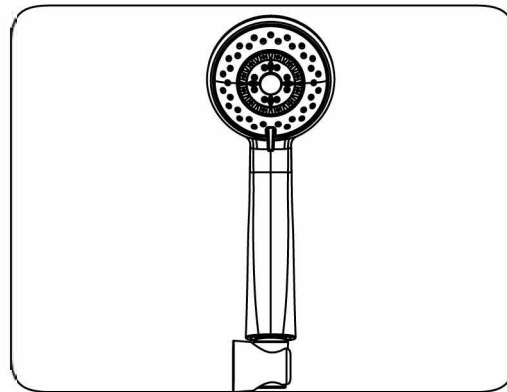

Important:

It is the conical end of the hose which grips into the holder. The sprayhead will not fit in the holder without the hose attached.

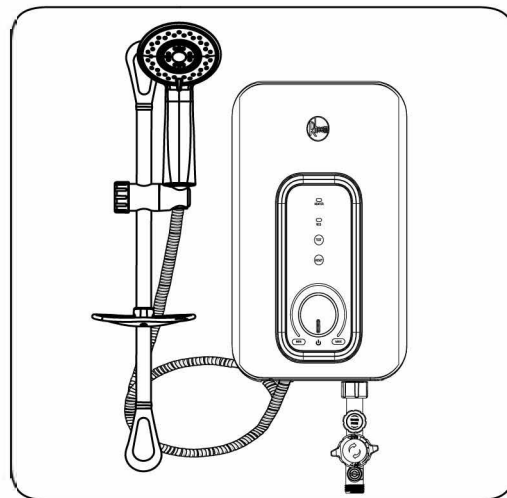

DO NOT switch on the electricity supply until the following procedure has been completed and the cover has been fitted.

The first operation of the shower is intended to flush out any remaining unit dirt particles, and to ensure the heater unit contains water before the elements are switched on.

This operation must be carried out with the flexible hose screwed to the outlet but without the sprayhead attached. Ensure the outlet of the flexible hose is directed to waste.

Turn ON the main water supply. Check if any water leaks from the pipe line.

Secure the cover in position with screws. **DO NOT OVERTIGHTEN.**

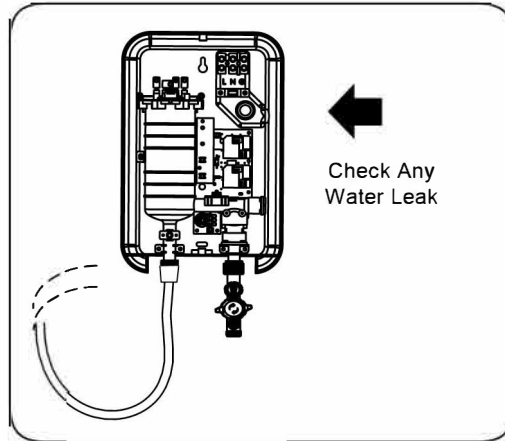

TESTING TEMPERATURE SETTING

Switch on the mains electric supply to the shower at the isolating switch.

The RCD will light meaning the unit is on standby.

Turn the knob clockwise to ON, the HEATER indicator will Light.

Turn the knob anti-clockwise to OFF; the HEATER indicator will switch OFF again.

Continual turn the knob clockwise. The temperature of the water should rise slightly.

Allow a few seconds for the warm water to reach the handset - this shows that the power setting is operating correctly.

Set the shower temperature by rotating the Knob as necessary. Turn the knob clockwise for hotter water and anticlockwise to OFF position for cooler water.

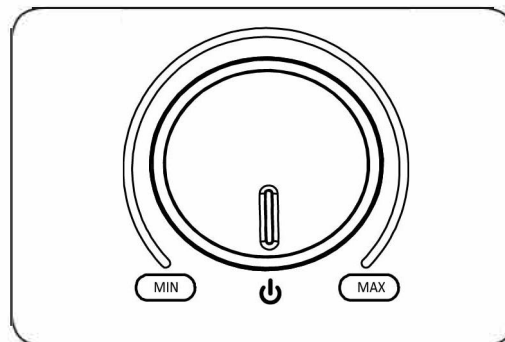
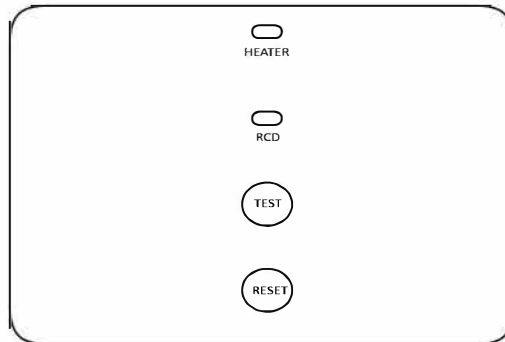

TESTING RCD
(For RCD model only)

Test the RCD by pressing the TEST Button. The heater and RCD light will turn OFF.

Press the RESET Button to switch ON the unit again. This shows the RCD should be in good condition.

Note!

If nothing happen when these button are pressed, do not use the heater, and contact your agent immediately.

Never attempt to repair the unit yourself.

Fit the shower fittings. Once the riser rail is fitted, the shower is ready for normal use.

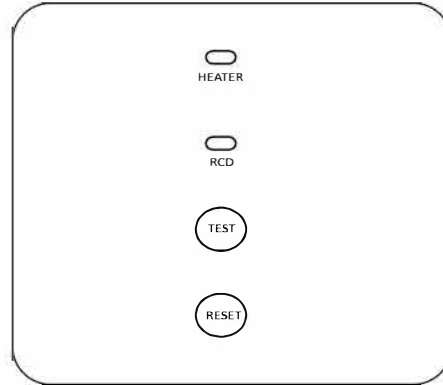

Important: Ensure the commissioning procedure has been carried out.

To start the shower, turn the stop valve handle anti-clockwise will allow water flow through the unit.

To stop the shower, turn the stop valve handle clockwise back to the position as shown in the figure.

CAUTION: Do Not Test Stop Valve under dry condition

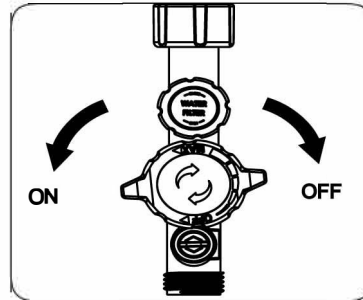

To adjust the shower temperature

The shower temperature is altered by increasing or decreasing the Power Control via the Control knob.

To increase the shower temperature
Turn the Control Knob clockwise towards the MAX Sign; this will increase the water temperature.

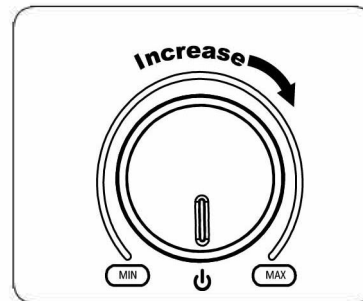

To decrease the shower temperature
Turn the Control Knob anti-clockwise towards the ON Sign; this will decrease the water temperature.

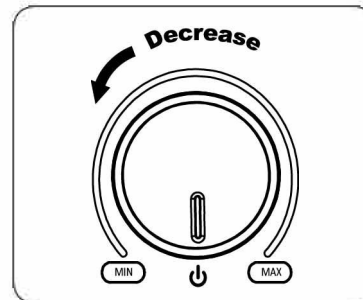

CAUTION: Be certain the showering temperature is satisfactory by testing with your hand before stepping under the sprayhead. There will always be a time delay of 10 to 15 seconds between selecting a flow rate and the water reaching the stable temperature for that flow rate. It is recommended that persons who may have difficulty understanding or operating the shower controls should not be left unattended whilst showering. Special consideration should be given to young children and the less able bodied.

CLEANING

NOTE: Do Not Use Thinner, Alcohol or Petrol

Many household cleaners contain abrasives and chemical substances, and should not be used for cleaning plated or plastic fittings. These finishes should be cleaned with a mild washing up detergent or soap solution, and then wiped dry using a soft cloth.

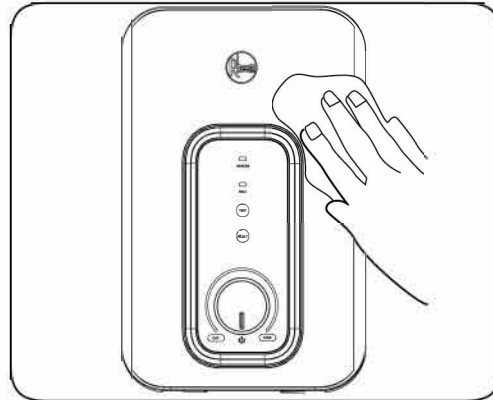

FILTER MAINTENANCE

It is recommended that the filter is periodically cleaned in order to maintain the performance of the shower.

'Open' the filter head from the stop valve. Remove the Filter Net and clean it using soft brush then wash it under running water. Ensure all dirt particles are removed.

'Close' it back after washing the filter.

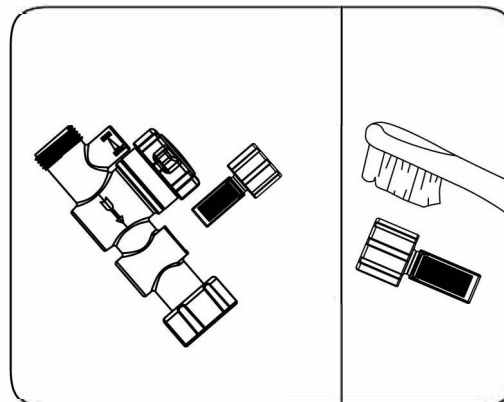

TESTING RCD

(For RCD model only)

Test the RCD once a month.

Turn On the unit with electric power and water supply.

Test the RCD by gently pressing TEST button. The RCD should be automatically tripped to OFF position. Press RESET to turn the unit back on.

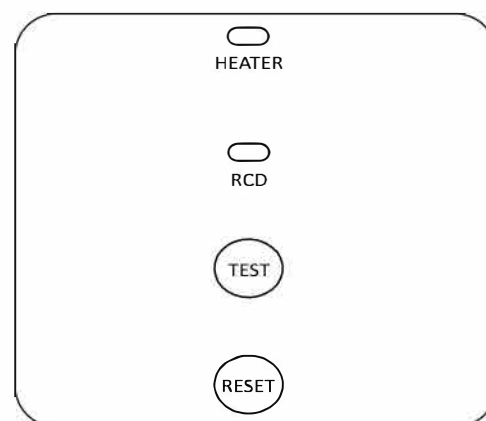

Fault / Symptom	Cause	Remedy
1. No shower coming out from the heater.	1.1 Interrupted of Water Supply	Check whether the water supply is available.
	1.2 Incoming water supply stop valves turned off.	Turn on stop valve.
	1.3 Dirt particles blocking inlet / outlet hole	Blocked sprayhead - clean or replace sprayhead. Blocked filter – see 'filter maintenance'.
2. Heater not functioning	2.1 Interrupted of Power Supply	Check if a main power cut. Check other appliances and if necessary, contact the local Electricity Supply Company.
	2.2 Low water supply to trigger flow switch	Heater requires minimum 2 litres/min water flow rate.
	2.3 Thermal Cut-Out has operated	Have the shower unit checked by a competent electrician or contact Customer Service.
	2.4 Malfunctioning on Flow Switch	
	2.5 Electrical malfunction	
3. Water too Hot	3.1 Not enough water flowing through the Unit.	Blocked sprayhead - clean or replace sprayhead. Blocked filter – see 'filter maintenance'.
	3.2 Increase in ambient water temperature.	Switch to reduced power setting and readjust flow rate to give the required temperature.
4. Water is not hot enough	4.1 Too much Water flow.	Reduce the flow rate by adjusting stop valve / flow ragulator.
	4.2 Reduction in the ambient water temperature	Adjusting power knob towards "MAX" and/or adjust stop valve towards "OFF" accordingly in order to get to the desired showering temperature.
	4.3 Electrical malfunction.	Have the shower unit checked by a competent electrician or contact Customer Service.
5. Water supply turn off but the indicator light unit still ON	5.1 Flow Switch malfunction	Have the shower unit checked by a competent electrician or contact Customer Service.
	5.2 Triac Faulty	

Specification RH-188-N / RH-188-R1 / RH-188-R2 Heater Series 18

Brand	RHEEM
Model	RH-188-N / RH-188-R1 / RH-188-R2
Power rating	3.3kW 230V ~ 50/60Hz 3.5kW 220V ~ 50/60Hz 3.8kW 240V ~ 50/60Hz 4.5kW 220V ~ 50/60Hz 5.5kW 220V ~ 50/60Hz
Rated Pressure	0 kPa
Inlet & outlet water connection	Ø 15mm (1/2" BSP)
Minimum water flow rate	2ℓ/min
Recommended water flow rate	4 - 6ℓ/min
Recommended inlet water pressure	100kPa (1 bar)
Dimensions (L x H x W)	300mm x 195mm x 97mm
Weight	1kgs (Individual Unit)
Maximum inlet Water Pressure	300kPa (3 bar)
Minimum inlet Water Pressure	20kPa (0.2 bar)
Ingress protection rating	IP25

SCHEMATIC WIRING DIAGRAM (RH-188-N)

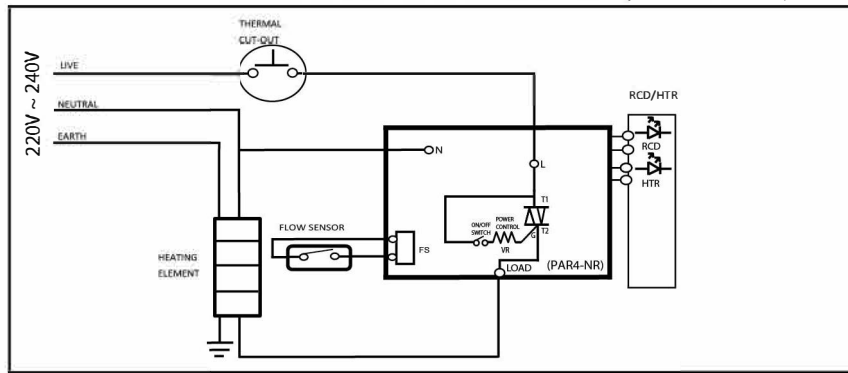

SCHEMATIC WIRING DIAGRAM (RH-188-R1)

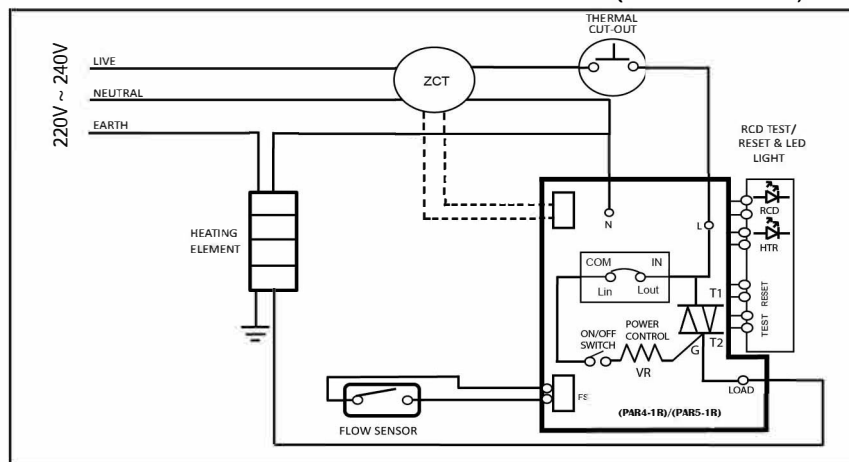

SCHEMATIC WIRING DIAGRAM (RH-188-R2)

