

Thermostatic Heater Ideal for Handwashing and Other Fixed or Variable Flow Applications

### Applications

- Handwashing
- Kitchen, bar, utility sinks
- Fixed or variable flow
- Ideal for multiple sensor or metering faucets
- Eyewash (EE models - 90°F max)
- Sanitation (S models - 180°F max)

### Features

- Self-diagnostics with intelligent controls actively protect heater installed environment
- SafeStart™ technology engages upon start-up to help avoid dry-fire occurrence
- Industry leading activation with 0.2 GPM turn on flow
- Digital LED display with accessible user interface communicates system status and heater operation feedback
- Silent operation on all models except for SPEX012240T
- Mounts in any orientation for a flexible installation
- Compact size fits almost anywhere; suitable for ADA compliant facilities
- Only one input line, hot or cold, needed for an easy installation
- Designed to deliver hot water to a single pipe faucet, mixing valves or mixing faucets
- Integral 3/8" compression fittings; no soldering or sweat connections required
- No T&P relief valve needed (check local codes)
- Save water and time by installing unit at the point-of-use
- Control system activates heater only on demand
- High temperature limit switch enables safe operation
- Active energy management with power modulation allows for thermostatic accuracy
- 5-year limited warranty on leaks, 1-year on parts

### Product Specifications

<b>Dimensions:</b>	10.75" H x 5.25" W x 3" D
<b>Product Weight:</b> (model dependent)	4 lb
<b>Cover:</b>	ABS-UL rated 94 5VA
<b>Color:</b>	White
<b>Adj. Temperature Range:</b>	70°F-140°F*
<b>Min. Operating Pressure:</b>	30 PSI
<b>Max. Operating Pressure:</b>	150 PSI
<b>Element:</b>	Replaceable Nichrome cartridge insert
<b>Fittings:</b>	3/8" compression fittings
<b>UL listed file number:</b>	E86887

U.S. Patent #'s: 4,762,980 and 4,960,976

### Special Design Service

Inquiries for units for unique applications are welcome. Call our Technical Service department at **1 800 543 6163**.  
\*Special settings available, see specification options

**NOTE:** Unit should not be used in a recirculation application. Contact an EEMAX representative for alternative recommendations.



**Note:** For optimum performance, mounting location should be located within 2 feet of fixture.

### Suggested Specification

Tankless water heater shall be an Eemax LavAdvantage model number SPEX\_\_\_\_\_.

Unit shall have ABS-UL 94 5VA rated cover. Unit shall allow mounting in any direction. Element shall be replaceable cartridge insert. Unit shall have replaceable filter in the inlet connector. Element shall be iron free, Nickel Chrome material. Tankless water heater to utilize complex algorithm, actively managing power application to real time system demand. Integrated flow meter, along with inlet and outlet temperature sensors provide data which allows the unit to instantly adapt to variations in input parameters. Heater shall be fitted with 3/8" compression fittings to eliminate need for soldering. Maximum operating pressure of 150 PSI. Accessible diagnostic features to include error/fault display. Hot water storage tanks prohibited. Unit shall be Eemax or approved equal.

Tankless water heater user interface must have the following capabilities:

- Field serviceable elements
- Selectable display including Celsius /Fahrenheit, setpoint, flow rate, inlet temperature outlet temperature, power factor
- Capable of displaying flow rate in gallons per minute & liters per minute
- Diagnostic features to include error/fault display
- Control board must maintain error/fault history of 5 events

Specification options to be included with SPEX models:

- \_\_\_ **EE** Emergency Eyewash. Meets ANSI tepid water
- \_\_\_ **ML** Multiple Lavatory. Factory set to 110°F. Max temp. 110°F
- \_\_\_ **S** Sanitation. Factory set to 120°F. Max temp. 180°F
- \_\_\_ **N4** NEMA 4 steel cabinet with powder coat finish
- \_\_\_ **N4X** NEMA 4 stainless steel, corrosion-resistant cabinet
- EX68031-15** Disconnect Switch (see page 42-43)

Thermostatic Heater Ideal for Handwashing and Other Fixed or Variable Flow Applications

MODEL NUMBER	KW	TOTAL AMP DRAW	CIRCUITS REQUIRED X BREAKER SIZE	RECOM'D WIRE SIZE (75° C/CU)	TURN ON (GPM)	TEMPERATURE RISE °F			
						0.35 GPM	0.5 GPM	1.0 GPM	2.0 GPM
<b>VOLTS 120</b>									
<b>SPEX1812T</b>	1.8	15	(1x15)	14 AWG	0.2	35°	25°	12°	6°
<b>SPEX1812T EE</b>	1.8	15	(1x15)	14 AWG	0.2	**	25°	12°	6°
<b>SPEX1812T S</b>	1.8	15	(1x15)	14 AWG	0.2	35°	25°	12°	6°
<b>SPEX2412T</b>	2.4	20	(1x20)	12 AWG	0.2	47°	33°	16°	8°
<b>SPEX2412T EE</b>	2.4	20	(1x20)	12 AWG	0.2	**	33°	16°	8°
<b>SPEX2412T S</b>	2.4	20	(1x20)	12 AWG	0.2	47°	33°	16°	8°
<b>SPEX3012T</b>	3.0	25	(1x25)	12 AWG	0.2	59°	41°	20°	10°
<b>SPEX3012T EE</b>	3.0	25	(1x25)	12 AWG	0.2	**	41°	20°	10°
<b>SPEX3012T S</b>	3.0	25	(1x25)	12 AWG	0.2	59°	41°	20°	10°
<b>SPEX3512T</b>	3.5	30	(1x30)	10 AWG	0.2	68°	48°	24°	12°
<b>SPEX3512T EE</b>	3.5	30	(1x30)	10 AWG	0.2	**	48°	24°	12°
<b>SPEX3512T ML</b>	3.5	30	(1x30)	10 AWG	0.2	68°	48°	24°	12°
<b>SPEX3512T S</b>	3.5	30	(1x30)	10 AWG	0.2	68°	48°	24°	12°
<b>VOLTS 240* Single Phase</b>									
<b>SPEX35T</b>	3.5	15	(1x15)	14 AWG	0.2	68°	48°	24°	12°
<b>SPEX35T (derated 208V perf.)</b>	2.6	12.6	(1x15)	14 AWG	0.2	51°	36°	18°	9°
<b>SPEX35T EE</b>	3.5	15	(1x15)	14 AWG	0.2	**	48°	24°	12°
<b>SPEX35T ML</b>	3.5	15	(1x15)	14 AWG	0.2	68°	48°	24°	12°
<b>SPEX35T S</b>	3.5	15	(1x15)	14 AWG	0.2	68°	48°	24°	12°
<b>SPEX48T</b>	4.8	20	(1x20)	12 AWG	0.2	94°	66°	33°	16°
<b>SPEX48T (derated 208V perf.)</b>	3.6	17.3	(1x20)	12 AWG	0.2	70°	49°	25°	12°
<b>SPEX48T EE</b>	4.8	20	(1x20)	12 AWG	0.2	**	†	33°	16°
<b>SPEX48T ML</b>	4.8	20	(1x20)	12 AWG	0.2	94°	66°	33°	16°
<b>SPEX48T S</b>	4.8	20	(1x20)	12 AWG	0.2	94°	66°	33°	16°
<b>SPEX55T</b>	5.5	23	(1x25)	12 AWG	0.2	107°	75°	38°	19°
<b>SPEX55T (derated 208V perf.)</b>	4.1	19.8	(1x25)	12 AWG	0.2	80°	56°	28°	14°
<b>SPEX55T EE</b>	5.5	23	(1x25)	12 AWG	0.2	**	†	38°	19°
<b>SPEX55T ML</b>	5.5	23	(1x25)	12 AWG	0.2	107°	75°	38°	19°
<b>SPEX55T S</b>	5.5	23	(1x25)	12 AWG	0.2	107°	75°	38°	19°
<b>SPEX65T</b>	6.5	27	(1x30)	10 AWG	0.2	†	89°	44°	22°
<b>SPEX65T (derated 208V perf.)</b>	4.9	23.4	(1x30)	10 AWG	0.2	95°	66°	33°	17°
<b>SPEX65T EE</b>	6.5	27	(1x30)	10 AWG	0.2	**	†	44°	22°
<b>SPEX65T ML</b>	6.5	27	(1x30)	10 AWG	0.2	†	89°	44°	22°
<b>SPEX65T S</b>	6.5	27	(1x30)	10 AWG	0.2	127°	89°	44°	22°
<b>SPEX75T</b>	7.5	32	(1x35)	10 AWG	0.2	†	102°	51°	26°
<b>SPEX75T (derated 208V perf.)</b>	5.6	27	(1x35)	10 AWG	0.2	†	77°	38°	19°
<b>SPEX75T EE</b>	7.5	32	(1x35)	10 AWG	0.2	**	†	51°	26°
<b>SPEX75T ML</b>	7.5	32	(1x35)	10 AWG	0.2	†	102°	51°	26°
<b>SPEX75T S</b>	7.5	32	(1x35)	10 AWG	0.2	146°	102°	51°	26°
<b>SPEX95T</b>	9.5	40	(1x40)	8 AWG	0.2	†	†	65°	32°
<b>SPEX95T (derated 208V perf.)</b>	6.9	33	(1x40)	8 AWG	0.2	†	94°	47°	23°
<b>SPEX95T EE</b>	9.5	40	(1x40)	8 AWG	0.2	**	†	†	32°
<b>SPEX95T ML</b>	9.5	40	(1x40)	8 AWG	0.2	†	†	65°	32°
<b>SPEX95T S</b>	9.5	40	(1x40)	8 AWG	0.2	†	103°	65°	32°
<b>SPEX012240T</b>	11.5	48	(1x50)	8 AWG	0.2	†	†	79°	39°
<b>SPEX012240T EE (derated 208V perf.)</b>	8.7	41.6	(1x50)	8 AWG	0.2	†	†	59°	30°
<b>SPEX012240T ML</b>	11.5	48	(1x50)	8 AWG	0.2	**	†	†	39°
<b>SPEX012240T S</b>	11.5	48	(1x50)	8 AWG	0.2	†	†	79°	39°

\* 240V units can be used on 208V single phase with approximately 25% reduced kilowatt output. Please note per UL standards the rating plate and installation instructions will all be according to a 240V applied voltage. Check with local officials prior to derating the electrical infrastructure.

† Temperature electronically limited to factory preset not to exceed temperature.

“C” indicates evaluation and compliance to either Underwriters Laboratories (UL) or Intertek (ETL) under CAN/CSA-C22.2 No. 64/No. 88.

\*\* Per ANSI Z358.1-2014 minimum flow of an eyewash station is 0.4 GPM @ 30 PSI.

**NOTE:** Unit should not be used in a recirculation application. Contact an EEMAX representative for alternative recommendations.

### Disconnect Switch Applications

EX68031-15
SPEX1812T, SPEX2412T, SPEX3012T, SPEX3512T, SPEX3208T, SPEX4208T, SPEX35T, SPEX48T, SPEX55T, SPEX65T, SPEX327T, SPEX4277T, SPEX60T, SPEX80T

MODEL NUMBER	KW	TOTAL AMP DRAW	CIRCUITS REQUIRED X BREAKER SIZE	RECOM'D WIRE SIZE (75° C/CU)	TURN ON (GPM)	TEMPERATURE RISE °F			
						0.35 GPM	0.5 GPM	1.0 GPM	2.0 GPM
<b>VOLTS 208 Single Phase</b>									
<b>SPEX3208T</b>	3.0	15	(1x15)	14 AWG	0.2	59°	41°	20°	10°
<b>SPEX3208T ML</b>	3.0	15	(1x15)	14 AWG	0.2	59°	41°	20°	10°
<b>SPEX4208T</b>	4.1	20	(1x20)	12 AWG	0.2	80°	56°	28°	14°
<b>SPEX4208T EE</b>	4.1	20	(1x20)	12 AWG	0.2	**	56°	28°	14°
<b>SPEX4208T ML</b>	4.1	20	(1x20)	12 AWG	0.2	80°	56°	28°	14°
<b>SPEX4208T S</b>	4.1	20	(1x20)	12 AWG	0.2	80°	56°	28°	14°
<b>SPEX8208T</b>	8.3	40	(1x40)	8 AWG	0.2	†	†	57°	28°
<b>SPEX8208T EE</b>	8.3	40	(1x40)	8 AWG	0.2	**	†	57°	28°
<b>SPEX8208T ML</b>	8.3	40	(1x40)	8 AWG	0.2	†	†	57°	28°
<b>SPEX8208T S</b>	8.3	40	(1x40)	8 AWG	0.2	†	†	57°	28°
<b>VOLTS 277 Single Phase</b>									
<b>SPEX3277T</b>	3.0	11	(1x15)	14 AWG	0.2	59°	41°	20°	10°
<b>SPEX3277T EE</b>	3.0	11	(1x15)	14 AWG	0.2	59°	41°	20°	10°
<b>SPEX3277T ML</b>	3.0	11	(1x15)	14 AWG	0.2	59°	41°	20°	10°
<b>SPEX3277T S</b>	3.0	11	(1x15)	14 AWG	0.2	59°	41°	20°	10°
<b>SPEX4277T</b>	4.1	15	(1x15)	14 AWG	0.2	80°	56°	28°	14°
<b>SPEX4277T EE</b>	4.1	15	(1x15)	14 AWG	0.2	**	56°	28°	14°
<b>SPEX4277T ML</b>	4.1	15	(1x15)	14 AWG	0.2	80°	56°	28°	14°
<b>SPEX4277T S</b>	4.1	15	(1x15)	14 AWG	0.2	80°	56°	28°	14°
<b>SPEX60T</b>	6.0	22	(1x25)	12 AWG	0.2	†	82°	41°	20°
<b>SPEX60T EE</b>	6.0	22	(1x25)	12 AWG	0.2	**	†	41°	20°
<b>SPEX60T ML</b>	6.0	22	(1x25)	12 AWG	0.2	†	82°	41°	20°
<b>SPEX60T S</b>	6.0	22	(1x25)	12 AWG	0.2	117°	82°	41°	20°
<b>SPEX80T</b>	8.0	29	(1x30)	10 AWG	0.2	†	109°	55°	27°
<b>SPEX80T EE</b>	8.0	29	(1x30)	10 AWG	0.2	**	†	55°	27°
<b>SPEX80T ML</b>	8.0	29	(1x30)	10 AWG	0.2	†	109°	55°	27°
<b>SPEX80T S</b>	8.0	29	(1x30)	10 AWG	0.2	†	109°	55°	27°
<b>SPEX90T</b>	9.0	33	(1x35)	10 AWG	0.2	†	†	61°	31°
<b>SPEX90T EE</b>	9.0	33	(1x35)	10 AWG	0.2	**	†	†	31°
<b>SPEX90T ML</b>	9.0	33	(1x35)	10 AWG	0.2	†	†	61°	31°
<b>SPEX90T S</b>	9.0	33	(1x35)	10 AWG	0.2	†	123°	61°	31°
<b>SPEX100T</b>	10.0	36	(1x40)	8 AWG	0.2	†	†	68°	34°
<b>SPEX100T EE</b>	10.0	36	(1x40)	8 AWG	0.2	**	†	†	34°
<b>SPEX100T ML</b>	10.0	36	(1x40)	8 AWG	0.2	†	†	68°	34°
<b>SPEX100T S</b>	10.0	36	(1x40)	8 AWG	0.2	†	137°	68°	34°

### Suffix Definitions

**EE** Meets ANSI Z358.1 tepid water requirements. Max. temperature 90°F

**ML** Multi lavs 0.2 turn on with 110° temp setting

**S** Sanitation not to exceed 180°

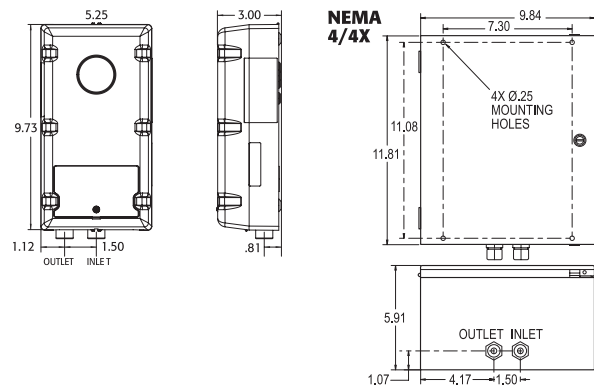

EX68031-16
SPEX75T, SPEX95T, SPEX012240T, SPEX4208T, SPEX8208T, SPEX90T, SPEX100T