



PROJECT NAME _____
LOCATION _____
ARCHITECT _____
ENGINEER _____
CONTRACTOR _____
SUBMITTED BY _____ DATE _____

UNIT SUMMARY

Quantity						
Unit Designation						
Model No.						
Total Cooling						
Sensible Cooling						
Air Ent. Evaporator						
Air Lvg. Evaporator						
Heating Input						
Heating Output						
CFM/ESP						
EER/SEER						
Electrical						
Minimum Ampacity						
Min.-Max. Breaker						
Net Unit Weight						
Accessory						
Catalog Form Number						

ACCESSORIES:

NOTES:

Endeavor® Line RF1PZ Air Handlers

Nominal Sizes: 1.5 to 3 Ton [5.0 to 16.3 kW]

JOB NAME _____ LOCATION _____

CONTRACTOR _____ ORDER NO. _____

ENGINEER _____ UNIT MODEL NO. _____

SUBMITTED FOR APPROVAL RECORD COIL MODEL NO. _____

DATE _____ AIR HANDLER MODEL NO. _____

UNIT DATA

COOLING PERFORMANCE

EFFICIENCY SEER

TOTAL CAPACITY* MBH [kW]

SENSIBLE CAPACITY* MBH [kW]

OUTDOOR DESIGN TEMP..... °F [°C] DB

TEMP. OF AIR ENTERING
EVAPORATOR COIL °F [°C] DB

..... °F [°C] WB

POWER INPUT REQUIREMENT kW
(*uses blower motor heat)

HEATING PERFORMANCE

EFFICIENCY HSPF

TOTAL CAPACITY* MBH [kW]

OUTDOOR DESIGN TEMP..... °F [°C] DB

TEMP. OF AIR ENTERING
EVAPORATOR COIL °F [°C] DB

SUPPLY AIR BLOWER PERFORMANCE

TOTAL AIR SUPPLY..... CFM [L/s]

TOTAL RESISTANCE EXTERNAL
TO UNIT IWG

BLOWER SPEED..... RPM

POWER OUTPUT REQUIREMENT BHP

MOTOR RATING HP [W]

POWER INPUT REQUIREMENT kW

ELECTRICAL DATA

POWER SUPPLY Hz

TOTAL UNIT AMPACITY..... AMPS

MINIMUM WIRE SIZE AWG

MAXIMUM OVERCURRENT DEVICE
FUSES/HACR BREAKER AMPS

CLEARANCES

ACCESS SIDE 24" [609.6 mm]

AIR INLETS 12" [304.8 mm]

ABOVE UNIT 60" [1524 mm]

FEATURES

- **Quiet Operation¹:** Provided by a cabinet construction with 1.0 inch of foil faced insulation for quieter sound characteristics
- **Front or Bottom Return with Aluminum Indoor Coil Design:** Are constructed of aluminum fins bonded to internally grooved aluminum tubing and are more corrosion resistant
- **Rugged Steel Cabinet Construction:** Designed for added strength and versatility
- **Most Compact Unit Design Available:** All standard air handler models are only 36" [915mm] in height
- **Field-installed Auxiliary Heater Kits:** Provide exact heat for indoor comfort and include circuit breakers which meet UL and cUL requirements for service disconnect
- **Less than 2% Cabinet Air Leakage at 1-inch H₂O:** When tested in accordance with AHRAE Standard 193

[] Designates Metric Conversions

¹Based on manufacturer's air handler offering, and the product's airflow stages, motor type and cabinet insulation. Sound levels are also dependent on air handler location and installation.



RF1PZ

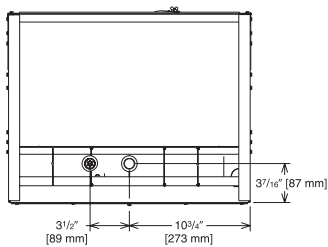
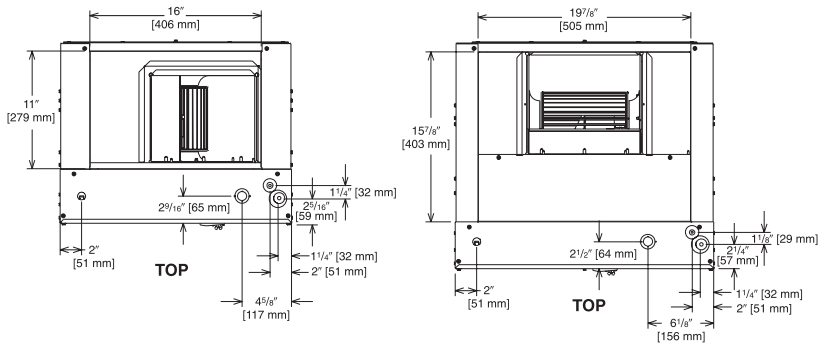

BOTTOM
1 1/2 & 2 TON [5.28 & 7.03 kW] MODELS

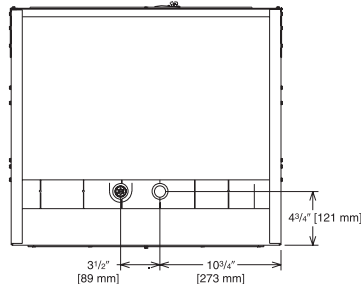

BOTTOM
2 1/2 & 3 TON [8.79 & 10.6 kW] MODELS

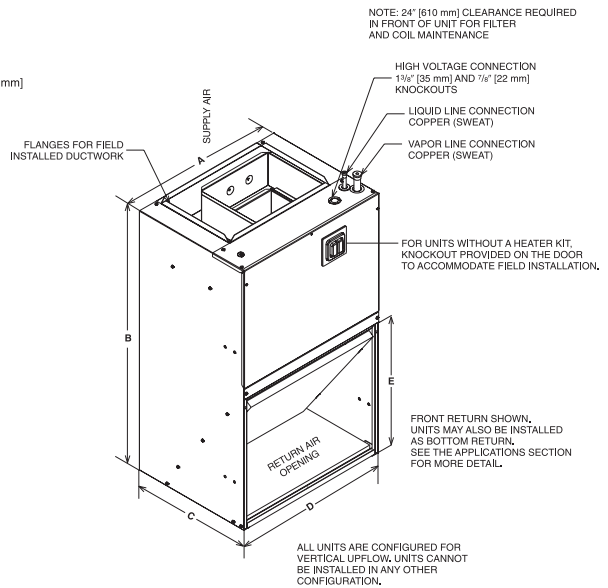

Unit Dimensions

Model	(A) Unit Width In. [mm]	(B) Unit Height In. [mm]	(C) Unit Depth In. [mm]	(D) Return Air Opening Width In. [mm]	(E) Return Air Opening Height In. [mm]	Filter Size in. x in. x in. [mm x mm x mm]	Air Flow CFM (Nom.) [L/s]		Unit Weight/ Shipping Weight (Lbs.) [kg]
							Low	High	
RF1PZ1821	21 1/2 [546.1]	36 [914.4]	17 [431.8]	20 [508.0]	17 7/16 [442.9]	20 X 20 X 1 [508 X 508 X 25.4]	600 [283]	—	80 [36] / 90 [41]
RF1PZ2421	21 1/2 [546.1]	36 [914.4]	17 [431.8]	20 [508.0]	17 7/16 [442.9]	20 X 20 X 1 [508 X 508 X 25.4]	800 [378]	—	80 [36] / 90 [41]
RF1PZ3024	24 [609.6]	36 [914.4]	21 [533.4]	23 [584.2]	21 3/8 [542.9]	20 X 25 X 1 [508 X 635 X 25.4]	1000 [472]	—	95 [43] x 105 [48]
RF1PZ3624	24 [609.6]	36 [914.4]	21 [533.4]	23 [584.2]	21 3/8 [542.9]	20 X 25 X 1 [508 X 635 X 25.4]	1200 [566]	—	95 [43] x 105 [48]

[] Designates Metric Conversions

Before proceeding with installation, refer to installation instructions packaged with each model, as well as complying with all Federal, State, Provincial, and Local codes, regulations, and practices.

5600 Old Greenwood Road
Fort Smith, Arkansas 72908

© 2023 Rheem Manufacturing Company. Rheem, Ruud and Friedrich trademarks owned by Rheem Manufacturing Company.

"In keeping with its policy of continuous progress and product improvement, Rheem reserves the right to make changes without notice."